

# drylin®

Drive technology

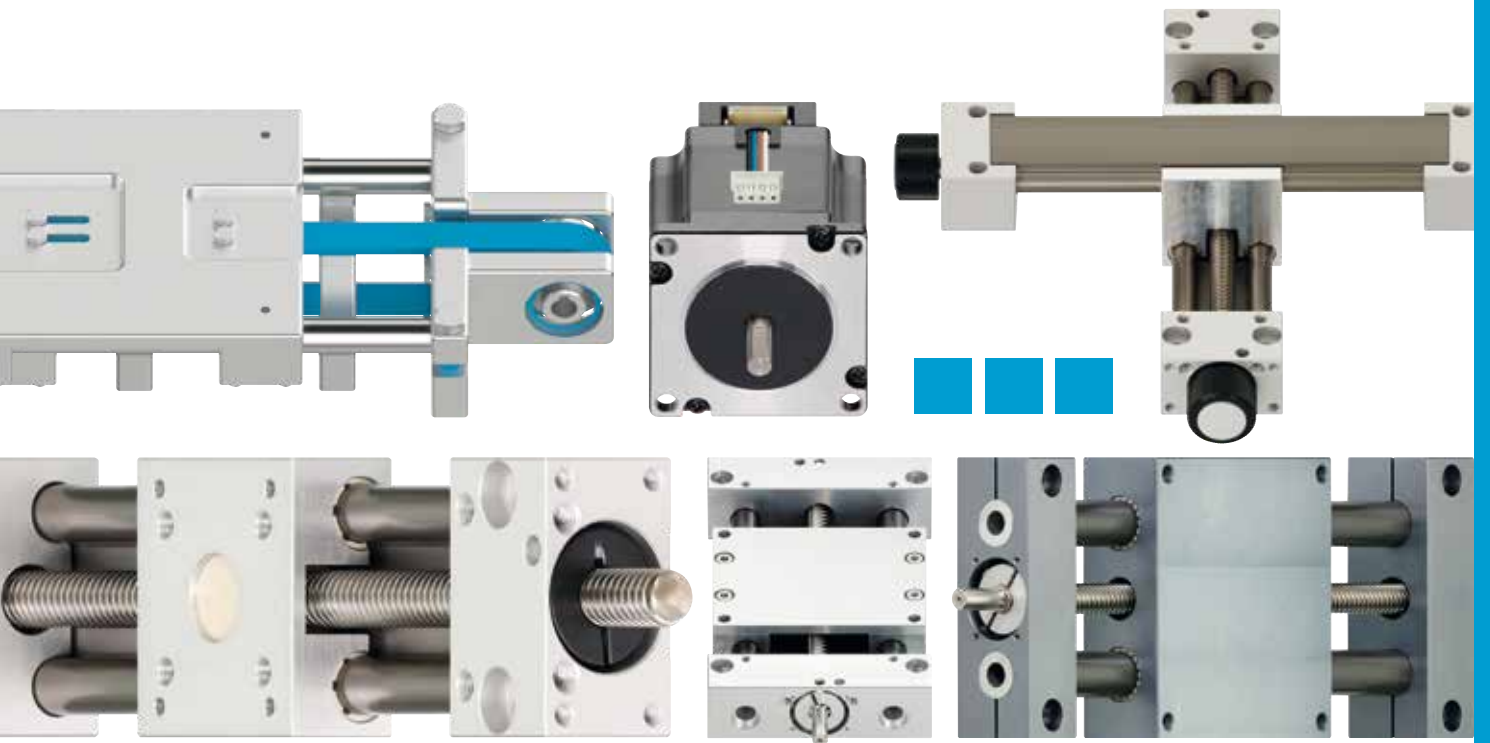

# ...plastics



**Camera/laser adjustment in labelling system**  
In a labelling system the camera and laser positioning are guided with two drylin® SHT/SLWE-XY XY table units. (Fa. Pago Etikettiersysteme GmbH)



**Pick & place**  
Quick and maintenance-free handling with drylin® toothed belt axes as a room linear robot (X, Y, Z-axis).

**Positioning of milling heads**

Aluminium dust and swarf cannot stick due to the absence of lubricants at any of the bearing points of the drylin® SHT linear module. (Berchtold GmbH)



**Electric actuator**

drylin® linear module combined with an electric actuator for use in a variety of format adjustments. (Festo AG & Co. KG)

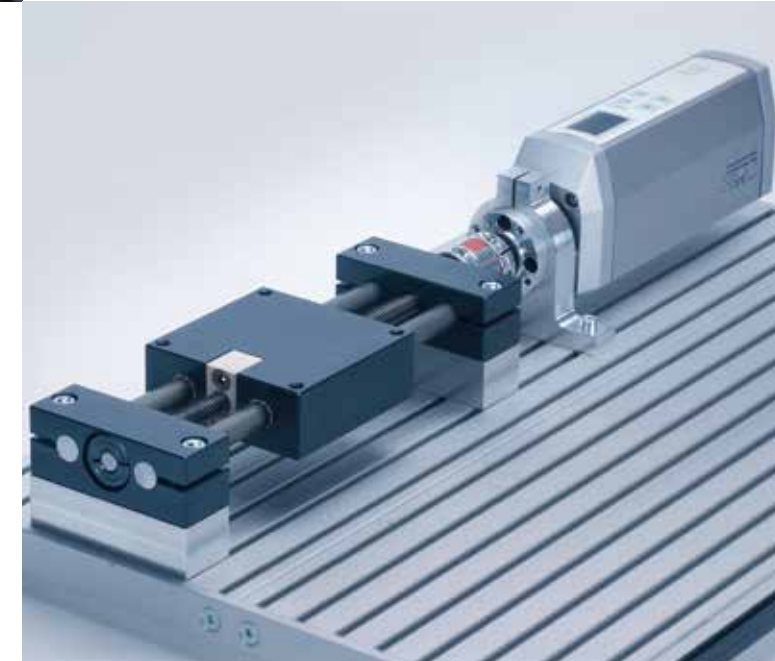

**Height adjustment of coding device**

The drylin® linear module gives variable and precise adjustment, free from any maintenance or lubrication. (Filtec Europe GmbH)



**Adjustment of inspection camera**

drylin® ZLW toothed belt axis in an inspection camera adjustment for checking the position of sealing rings. (OLPE Jena GmbH)



drylin® drive technology - SHT linear modules

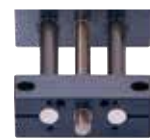

Self-locking:

SHT

► Page 524



Axial pre-load, radial adjustment:

SHT-PL

► Page 525



Compact design:

SHTC

► Page 526



The fast one with dryspin® high helix thread:

SHTS

► Page 527



With ball bearing supported lead screw:

SHT-BB

► Page 528



Made of stainless steel:

SHT-ESJ

► Page 530

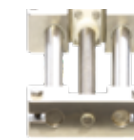

Hygienic design:

SHTC-HYD

► Page 531



With quick-release mechanism:

SHTC-FF

► Page 532

SHT linear modules



With quick-release mechanism:

SHT-FF

► Page 533



XY tables:

SHT-XY

► Page 534



Self-locking:

SLW

► Page 538



New

With short carriages:

SLWC

► Page 540



Axial pre-load, radial adjustment:

SLWE-PL

► Page 541



With ball bearing supported lead screws:

SLEW-BB

► Page 542



The fast one with dryspin® high helix thread:

SLWS

► Page 544



With protected lead screw:

SLW-PT

► Page 546

SLW linear modules



Dual action linear system:

SLWT

► Page 547



Stainless steel version:

SLW-ES

► Page 548

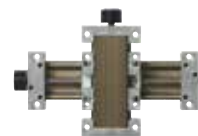

XY tables:

SLW-XY

► Page 550



XY tables - stainless steel version:

SLW-XY-ES

► Page 552

SAW linear modules



Robust design:

SAW

► Page 556



Clearance-reduced with pre-load:

SAW-PL

► Page 557



Direct drive in short design:

SAWC

► Page 558

easytube linear units



Single tube linear unit easytube:

SET

► Page 562



easytube with double flange:

SET-F

► Page 563



easytube with single flange:

SETB

► Page 564



easytube with measurement scale:

SETM-SC

► Page 565



easytube "light":

SETC

► Page 566

Flat linear modules



Ball bearing supported lead screws based on drylin® T:

SLT-BB

► Page 569

Miniature linear modules



Pre-load miniature linear module:

SLN-27

► Page 573



Prism module for precise adjustment:

SLNV

► Page 574



Standard toothed belt axes:

ZLW

► Page 586



Modular toothed belt axes:

ZLW-AL/-ES

► Page 588

ZLW toothed belt axes

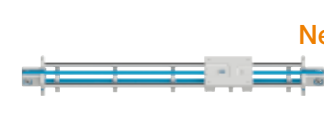

New

Linear axis with hygienic design:

ZLW-HYD

► Page 590



Tandem toothed belt axis:

ZLWT

► Page 591



Opposite drive toothed belt axes:

ZLW-OD

► Page 592



Cost-effective econ toothed belt axis:

ZLN econ

► Page 594

## drylin® electric drive technology - cantilever axes



**Dynamic z-axis for linear robot structures:**  
drylin® GRW  
▶ Page 596

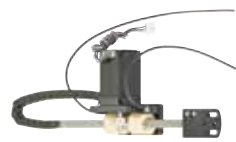

**Extremely light axis for pick & place:**  
drylin® GRQ  
▶ Page 597



**Lightweight z-axis with direct rack drive:**  
drylin® GRR  
▶ Page 598



**Cantilever axis:**  
drylin® ZAW  
▶ Page 599

## econ entry-level series



**The SLW entry-level model:**  
SLWP-E  
▶ Page 604



**The SLT entry-level model:**  
SLTP-E  
▶ Page 605



**The SHT miniature version:**  
SHTP-AWM  
▶ Page 606



**The lightweight entry-level model:**  
SHTP  
▶ Page 607

## econ entry-level series



**The cost-effective SHT version:**  
SHTP-AWM  
▶ Page 608

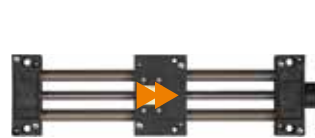

**With quick-release mechanism:**  
SHTP-AWM-FF  
▶ Page 609



**Miniature linear modules:**  
SLN basic  
▶ Page 610



**Cost-effective toothed belt axis:**  
ZLW-E  
▶ Page 611

## drylin® accessories - control elements



**Accessories for manual positioning and Format adjustment**  
▶ Page 613

## drylin® E - motors



**Stepper motors:**  
drylin® stepper motors  
▶ Page 632



**Specialist stepper motors**  
▶ Page 640

## drylin® E - motors



**Lead screw stepper motors:**  
drylin® lead screw stepper motors  
▶ Page 642



**EC/BLDC motors:**  
drylin® EC/BLCD motors  
▶ Page 647



**DC motors:**  
drylin® direct-current motors  
▶ Page 651

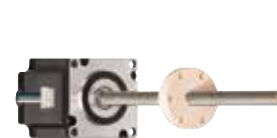

**Linear actuators:**  
drylin® linear actuators  
▶ Page 660



**Motor control system:**  
D1 dryve  
▶ Page 662



**Motor control system:**  
D3 dryve  
▶ Page 663



**Motor control system:**  
D7/8/9 dryve  
▶ Page 664



**Motor control system:**  
D5/6 dryve  
▶ Page 665

## drylin® E - motors



**Motor-driven:**  
Planetary gear for stepper motors  
▶ Page 666



**Jaw couplings:**  
Vibration dampening and pluggable  
▶ Page 669



**Accessories for drylin® E**  
Motor flanges, cables and mounting accessories  
▶ Page 671

## drylin® E - accessories

## Low Cost Automation



**Articulated arm robot**  
ReBeL® cobot  
roboLink® DC/DP  
▶ Page 697



**Linear robots and other Kinematics**  
▶ Page 703



**SCARA robot**  
▶ Page 714



**roboLink® igus® robot control system**  
▶ Page 718

## Low Cost Automation



**Low Cost Automation Accessories**  
▶ Page 720



**roboLink® D worm gears**  
▶ Page 724



**drygear® Apero® modular gearbox system**  
▶ Page 730



**drygear® strain wave gear**  
▶ Page 739



**drygear® planetary gearboxes**  
▶ Page 740



The drylin® product portfolio provides lubrication-free linear modules that are driven either by a trapezoidal thread, high helix thread or toothed belt. The user can choose a suitable individual solution from lightweight solid plastic units up to heavy-duty stainless steel solutions. In all systems, the stroke length is freely selectable and the drive given either via hand wheel or motor.

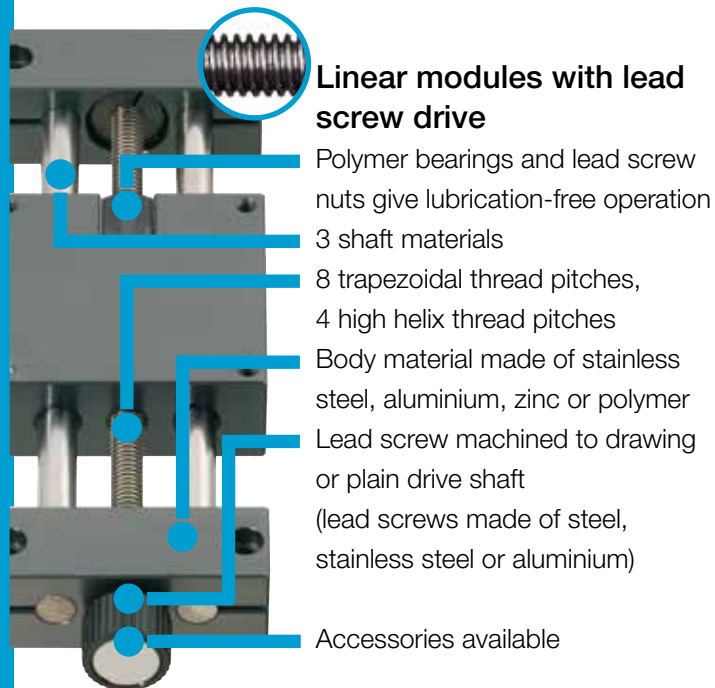

## Linear modules with lead screw drive

- Polymer bearings and lead screw nuts give lubrication-free operation
- 3 shaft materials
- 8 trapezoidal thread pitches, 4 high helix thread pitches
- Body material made of stainless steel, aluminium, zinc or polymer
- Lead screw machined to drawing or plain drive shaft (lead screws made of steel, stainless steel or aluminium)

Accessories available

- Standard** min. 0°C Max. +60°C
- Stainless steel version with iglidur® X** Min. 0°C Max. +180°C

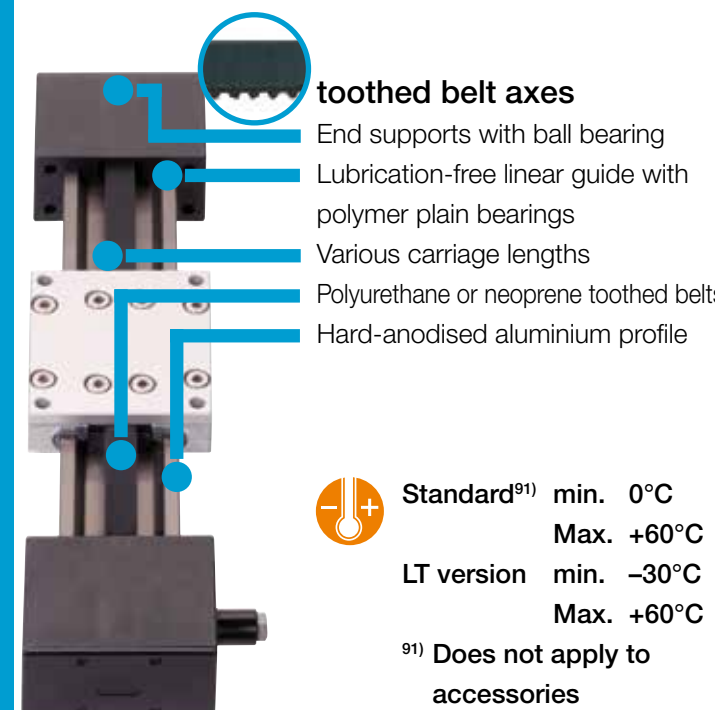

## toothed belt axes

- End supports with ball bearing
- Lubrication-free linear guide with polymer plain bearings
- Various carriage lengths
- Polyurethane or neoprene toothed belts
- Hard-anodised aluminium profile

- Standard<sup>91)</sup>** min. 0°C Max. +60°C
- LT version** min. -30°C Max. +60°C

<sup>91)</sup> Does not apply to accessories



### When to use it?

- For format adjustments
- In extreme environments
- When a cost-effective, ready-to-fit solution is required
- When corrosion resistance is required
- When a quiet operation is required



### When not to use it?

- When high loads need to travel at highly dynamic forces
- When positioning accuracy <0.1mm is required
- When high running performance is required in continuous operation



### When to use it?

- Fast positioning of small loads
- Quiet operation
- Slim design
- Underwater use with UW belt
- Cost-effective solution as basic version
- Continuous operation



### When not to use it?

- When high loads need to travel at highly dynamic forces
- When positioning accuracy <0.1mm is required



## SHT linear modules

- Drive: trapezoidal or high-helix lead screw
  - Ball-bearing mounted lead screw drives for higher dynamic forces
  - Carriage in either quad block or compact design
- Page 521



## SAW linear modules

- Drive: Ball bearing supported lead screw
  - Rail profile in high design
  - Extremely torsion-resistant
- Page 553



## SLT linear modules

- Variable pitch
  - Adjustable drylin® T miniature carriage
  - Lead screw arrangement can be selected either left or right
- Page 567



## ZLW toothed belt axes

- Versions basic, standard and econ
  - For fast positioning
  - End supports with ball bearing
- Page 575



## drylin® - automation

- Lubrication-free linear modules with motor
  - Ready to install with motor, cable and initiator
  - Drive: Lead screw, toothed belt or rack
- Page 689



## SLW linear modules

- Based on drylin® W
  - Drive: trapezoidal or high-helix lead screw
  - Torsion-resistant double shaft systems
- Page 535



## SET easytube linear modules

- Corrosion-resistant
  - Lightweight due to aluminium and polymer
  - Simple, smooth design, protected lead screw
- Page 559



## SLN miniature linear modules

- Based on drylin® N, low installation height
  - Basic, adjustable and pre-load versions
- Page 571



## econ entry-level series

- Lightweight
  - Cost-effective
  - Corrosion-resistant
- Page 601



## Cantilever axis GRW

- Dynamic force transmission through rack
  - Assembly option for limit and reference switch
- Page 596

## Accessories for linear modules

- Position indicator, hand wheels, lead screw clamps, angular drives and more
- Page 613

| Linear module |         |        |           |                            |                     |                                 |
|---------------|---------|--------|-----------|----------------------------|---------------------|---------------------------------|
| Linear module | Shaft Ø | Thread | Pitch     | Lead screw<br>Self-locking | Carriage length     | Motor<br>connection<br>possible |
|               | [mm]    |        |           |                            | [mm]                |                                 |
| SHT(C)-08     | 8       | TR     | 6x2P1     | +                          | 38 / 65             | +                               |
|               |         | DS     | 6.35x2.54 | -                          | 38 / 65             | +                               |
|               |         | DS     | 6.35x5.08 | -                          | 38 / 65             | +                               |
|               |         | DS     | 6.35x12.7 | -                          | 38 / 65             | +                               |
|               |         | DS     | 6.35x25.4 | -                          | 38 / 65             | +                               |
| SHT(C)-12     | 12      | TR     | 10x2      | +                          | 30 / 85             | +                               |
|               |         | DS     | 10x2      | +                          | 30 / 85             | +                               |
|               |         | TR     | 10x3      | +                          | 30 / 85             | +                               |
|               |         | DS     | 10x3      | -                          | 30 / 85             | +                               |
|               |         | TR     | 10x4      | +                          | 30 / 85             | +                               |
|               |         | DS     | 10x12     | -                          | 30 / 85             | +                               |
|               |         | DS     | 10x25     | -                          | 30 / 85             | +                               |
|               |         | DS     | 10x50     | -                          | 30 / 85             | +                               |
| SHT(C)-20     | 20      | TR     | 18x4      | +                          | 36 / 130            | +                               |
|               |         | DS     | 18x4      | +                          | 36 / 130            | +                               |
|               |         | TR     | 18x8P4    | +                          | 36 / 130            | +                               |
|               |         | DS     | 18x24     | -                          | 36 / 130            | +                               |
|               |         | DS     | 18x40     | -                          | 36 / 130            | +                               |
|               |         | DS     | 18x80     | -                          | 36 / 130            | +                               |
|               |         | DS     | 18x100    | -                          | 36 / 130            | +                               |
| SHT(C)-30     | 30      | DS     | 20x5      | -                          | 50 / 180            | +                               |
|               |         | DS     | 20x10     | -                          | 50 / 180            | +                               |
|               |         | DS     | 20x20     | -                          | 50 / 180            | +                               |
|               |         | DS     | 20x50     | -                          | 50 / 180            | +                               |
|               |         | DS     | 20x60     | -                          | 50 / 180            | +                               |
|               |         | DS     | 20x80     | -                          | 50 / 180            | +                               |
|               |         | DS     | 20x90     | -                          | 50 / 180            | +                               |
| SHTC-40       | 40      | TR     | 24x5      | +                          | 50 / 180            | +                               |
| SHTC-50       | 50      | TR     | 30x6      | +                          | 80                  | +                               |
| SLW-0630      | 6       | TR     | 8x1.5     | +                          | 20 / 60 / 100 / 150 | +                               |
|               |         | DS     | 8x10      | -                          | 20 / 60 / 100 / 150 | +                               |
|               |         | DS     | 8x15      | -                          | 20 / 60 / 100 / 150 | +                               |
| SLW-0660      | 6       | TR     | 8x1.5     | +                          | 60 / 100 / 150      | +(121)                          |
|               |         | DS     | 8x10      | -                          | 60 / 100 / 150      | +(121)                          |
|               |         | DS     | 8x15      | -                          | 60 / 100 / 150      | +(121)                          |

<sup>120)</sup> When configuring your linear module, we ask that you note the igus® specifications for maximum stroke lengths. The performance and load specifications shown above for all drive units are based exclusively on stroke lengths within the recommended values. Exceeding these can result in undesirable effects to the function such as increased wear and noise. Belt or lead screw contact cannot be excluded, and the rated performance and load specifications may not be attainable.

| Lead screw with plain bearing support <sup>121)</sup> |                                 |                                  |            |                | Ball bearing supported lead screws |                                 |                                  |            |                |
|---|---------------------------------|----------------------------------|------------|----------------|------------------------------------|---------------------------------|----------------------------------|------------|----------------|
| Max. stroke length <sup>120)</sup>                    | Max. static axial load capacity | Max. static radial load capacity | Max. speed | Max. feed rate | Max. stroke length <sup>120)</sup> | Max. static axial load capacity | Max. static radial load capacity | Max. speed | Max. feed rate |
| [mm]  | [N]                             | [N]                              | [rpm]      | [m/min]        | [mm]                               | [N]                             | [N]                              | [rpm]      | [m/min]        |
| 300   | 100                             | 400                              | 100        | 0.1            | 300                                | 100                             | 360                              | 500        | 0.5            |
| 300   | 100                             | 360                              | 100        | 0.254          | 300                                | 100                             | 360                              | 1,000      | 2.54           |
| 300   | 70                              | 280                              | 100        | 0.508          | 300                                | 70                              | 280                              | 1,000      | 5.08           |
| 300   | 35                              | 140                              | 100        | 1.27           | 300                                | 35                              | 140                              | 1,000      | 12.7           |
| 300   | 18                              | 72                               | 100        | 2.54           | 300                                | 18                              | 72                               | 1,000      | 25.4           |
| 500   | 700                             | 2,800                            | 100        | 0.2            | 500                                | 350                             | 1,400                            | 500        | 1.0            |
| 500   | 700                             | 2,800                            | 100        | 0.2            | 500                                | 500                             | 2,000                            | 1,000      | 2.0            |
| 500   | 500                             | 2,000                            | 100        | 0.3            | 500                                | 350                             | 1,400                            | 500        | 1.5            |
| 500   | 500                             | 2,000                            | 100        | 0.2            | 500                                | 500                             | 2,000                            | 1,000      | 3.0            |
| 500   | 400                             | 1,600                            | 100        | 0.4            | 500                                | 350                             | 1,400                            | 500        | 2.0            |
| 500   | 400                             | 1,600                            | 100        | 1.2            | 500                                | 300                             | 1,200                            | 1,000      | 12.0           |
| 500   | 250                             | 1,000                            | 100        | 2.5            | 500                                | 250                             | 1,000                            | 1,000      | 25.0           |
| 500   | 100                             | 400                              | 100        | 5.0            | 500                                | 100                             | 400                              | 1,000      | 50.0           |
| 900   | 1,600                           | 6,400                            | 100        | 0.4            | 900                                | 1,000                           | 4,000                            | 500        | 2.0            |
| 900   | 1,600                           | 6,400                            | 100        | 0.4            | 900                                | 1,000                           | 4,000                            | 500        | 2.0            |
| 900   | 1,200                           | 4,800                            | 100        | 0.4            | 900                                | 1,200                           | 4,800                            | 500        | 2.0            |
| 900   | 800                             | 3,200                            | 100        | 2.4            | 900                                | 800                             | 3,200                            | 1,000      | 24.0           |
| 900   | 500                             | 2,000                            | 100        | 4.0            | 900                                | 500                             | 2,000                            | 1,000      | 40.0           |
| 900   | 250                             | 1,000                            | 100        | 8.0            | 900                                | 250                             | 1,000                            | 900        | 72.0           |
| 900   | 200                             | 800                              | 100        | 10.0           | 900                                | 200                             | 800                              | 750        | 75.0           |
| -   | -                               | -                                | -          | -              | 1,000                              | 1,500                           | 6,000                            | 1,000      | -              |
| -   | -                               | -                                | -          | -              | 1,000                              | 1,200                           | 4,800                            | 1,000      | -              |
| -   | -                               | -                                | -          | -              | 1,000                              | 1,000                           | 4,000                            | 1,000      | -              |
| -   | -                               | -                                | -          | -              | 1,000                              | 700                             | 2,800                            | 1,000      | -              |
| -   | -                               | -                                | -          | -              | 1,000                              | 600                             | 2,400                            | 1,000      | -              |
| -   | -                               | -                                | -          | -              | 1,000                              | 400                             | 1,600                            | 1,000      | -              |
| -   | -                               | -                                | -          | -              | 1,000                              | 300                             | 1,200                            | 1,000      | -              |
| 1,000   | 2,500                           | 10,000                           | 100        | 0.5            | 1,000                              | 1,500                           | 6,000                            | 500        | 2.5            |
| 1,500   | 4,000                           | 16,000                           | 100        | 0.5            | -                                  | -                               | -                                | -          | -              |
| 1,500   | 6,250                           | 25,000                           | 100        | 0.6            | -                                  | -                               | -                                | -          | -              |
| 300   | 100                             | 400                              | 100        | 0.15           | 300                                | 100                             | 400                              | 500        | 0.75           |
| 300   | 100                             | 400                              | 100        | 1.0            | 300                                | 100                             | 400                              | 1,000      | 10.0           |
| 300   | 100                             | 400                              | 100        | 1.5            | 300                                | 100                             | 400                              | 1,000      | 15.0           |
| 300   | 100                             | 200                              | 100        | 0.15           | 300                                | 100                             | 400                              | 500        | 0.75           |
| 300   | 100                             | 400                              | 100        | 1.0            | 300                                | 100                             | 400                              | 1,000      | 10.0           |
| 300   | 100                             | 400                              | 100        | 1.5            | 300                                | 100                             | 400                              | 1,000      | 15.0           |

<sup>121)</sup> Linear modules on plain bearings require an aluminium shaft end support when connected to a motor. The technical values in the specifications are maximum values for each criterion, e.g. speed, stroke length etc.; they are not cumulative values. Suitability under consideration of the individual parameters for usage can be checked online at [www.igus.eu/linearmodule-finder](http://www.igus.eu/linearmodule-finder).



| Linear module |         |        |                      |                            |                      |                                 |
|---------------|---------|--------|----------------------|----------------------------|----------------------|---------------------------------|
| Linear module | Shaft Ø | Thread | Pitch                | Lead screw<br>Self-locking | Carriage length      | Motor<br>connection<br>possible |
|               | [mm]    |        |                      |                            | [mm]                 |                                 |
| SLW-1030      | 10      | TR     | 10x2                 | +                          | 48 / 69 / 100        | +                               |
|               |         | DS     | 10x2                 | +                          | 48 / 69 / 100        | +                               |
|               |         | TR     | 10x3                 | +                          | 48 / 69 / 100        | +                               |
|               |         | DS     | 10x3                 | -                          | 48 / 69 / 100        | +                               |
|               |         | TR     | 10x4                 | +                          | 48 / 69 / 100        | +                               |
|               |         | DS     | 10x12                | -                          | 48 / 69 / 100        | +                               |
|               |         | DS     | 10x25                | -                          | 48 / 69 / 100        | +                               |
| SLW-1040      | 10      | TR     | 10x2                 | +                          | 29 / 69 / 87 / 100   | +                               |
|               |         | DS     | 10x2                 | +                          | 29 / 69 / 87 / 100   | +                               |
|               |         | TR     | 10x3                 | +                          | 29 / 69 / 87 / 100   | +                               |
|               |         | DS     | 10x3                 | -                          | 29 / 69 / 87 / 100   | +                               |
|               |         | TR     | 10x4                 | +                          | 29 / 69 / 87 / 100   | +                               |
|               |         | DS     | 10x12                | -                          | 29 / 69 / 87 / 100   | +                               |
|               |         | DS     | 10x25                | -                          | 29 / 69 / 87 / 100   | +                               |
| SLW-1080      | 10      | DS     | 10x50                | -                          | 29 / 69 / 87 / 100   | +                               |
|               |         | TR     | 10x2                 | +                          | 100 / 150 / 200      | +                               |
|               |         | DS     | 10x2                 | +                          | 100 / 150 / 200      | +                               |
|               |         | TR     | 10x3                 | +                          | 100 / 150 / 200      | +                               |
|               |         | DS     | 10x3                 | -                          | 100 / 150 / 200      | +                               |
|               |         | TR     | 10x4                 | +                          | 100 / 150 / 200      | +                               |
|               |         | DS     | 10x12                | -                          | 100 / 150 / 200      | +                               |
| SLW-10120     | 10      | DS     | 10x25                | -                          | 100 / 150 / 200      | +                               |
|               |         | DS     | 10x50                | -                          | 100 / 150 / 200      | +                               |
|               |         | TR     | 10x2                 | +                          | 100 / 150 / 200      | +                               |
|               |         | DS     | 10x2                 | +                          | 100 / 150 / 200      | +                               |
|               |         | TR     | 10x3                 | +                          | 100 / 150 / 200      | +                               |
|               |         | DS     | 10x3                 | -                          | 100 / 150 / 200      | +                               |
|               |         | TR     | 10x4                 | +                          | 100 / 150 / 200      | +                               |
| SLW-1660      | 16      | DS     | 10x12                | -                          | 100 / 150 / 200      | +                               |
|               |         | DS     | 10x25                | -                          | 100 / 150 / 200      | +                               |
|               |         | DS     | 10x50                | -                          | 100 / 150 / 200      | +                               |
|               |         | TR     | 14x3                 | +                          | 36 / 100 / 150 / 200 | +                               |
|               |         | TR     | 14x4                 | +                          | 36 / 100 / 150 / 200 | +                               |
|               |         | DS     | 14x4                 | +                          | 36 / 100 / 150 / 200 | +                               |
| DS            | 14x25   | -      | 36 / 100 / 150 / 200 | +                          |                      |                                 |
| DS            | 14x30   | -      | 36 / 100 / 150 / 200 | +                          |                      |                                 |
| DS            | 14x40.6 | -      | 36 / 100 / 150 / 200 | +                          |                      |                                 |

<sup>120)</sup> When configuring your linear module, we ask that you note the igus® specifications for maximum stroke lengths. The performance and load specifications shown above for all drive units are based exclusively on stroke lengths within the recommended values. Exceeding these can result in undesirable effects to the function such as increased wear and noise. Belt or lead screw contact cannot be excluded, and the rated performance and load specifications may not be attainable.

| Lead screw with plain bearing support <sup>121)</sup> |                                 |                                  |            |                | Ball bearing supported lead screws |                                 |                                  |            |                |
|---|---------------------------------|----------------------------------|------------|----------------|------------------------------------|---------------------------------|----------------------------------|------------|----------------|
| Max. stroke length <sup>120)</sup>                    | Max. static axial load capacity | Max. static radial load capacity | Max. speed | Max. feed rate | Max. stroke length <sup>120)</sup> | Max. static axial load capacity | Max. static radial load capacity | Max. speed | Max. feed rate |
| [mm]  | [N]                             | [N]                              | [rpm]      | [m/min]        | [mm]                               | [N]                             | [N]                              | [rpm]      | [m/min]        |
| -   | -                               | -                                | -          | -              | 500                                | 250                             | 1,000                            | 1,000      | 2.0            |
| -   | -                               | -                                | -          | -              | 500                                | 500                             | 2,000                            | 500        | 1.0            |
| -   | -                               | -                                | -          | -              | 500                                | 400                             | 1,600                            | 500        | 1.5            |
| -   | -                               | -                                | -          | -              | 500                                | 500                             | 2,000                            | 500        | 1.5            |
| -   | -                               | -                                | -          | -              | 500                                | 100                             | 400                              | 1,000      | 4.0            |
| -   | -                               | -                                | -          | -              | 500                                | 500                             | 2,000                            | 1,000      | 12.0           |
| -   | -                               | -                                | -          | -              | 500                                | 500                             | 2,000                            | 1,000      | 25.0           |
| 500   | 700                             | 2,800                            | 100        | 0.2            | 500                                | 500                             | 2,000                            | 500        | 1.0            |
| 500   | 700                             | 2,800                            | 100        | 0.2            | 500                                | 500                             | 2,000                            | 500        | 2.0            |
| 500   | 700                             | 2,000                            | 100        | 0.3            | 500                                | 500                             | 2,000                            | 500        | 1.5            |
| 500   | 500                             | 2,000                            | 100        | 0.3            | 500                                | 500                             | 2,000                            | 1,000      | 3.0            |
| 500   | 400                             | 1,600                            | 100        | 0.4            | 500                                | 400                             | 1,600                            | 500        | 2.0            |
| 500   | 400                             | 1,600                            | 100        | 1.2            | 500                                | 300                             | 1,200                            | 1,000      | 12.0           |
| 500   | 250                             | 1,000                            | 100        | 2.5            | 500                                | 250                             | 1,000                            | 1,000      | 25.0           |
| 500   | 100                             | 400                              | 100        | 5.0            | 500                                | 100                             | 400                              | 1,000      | 50.0           |
| 500   | 700                             | 2,800                            | 100        | 0.2            | 500                                | 500                             | 2,000                            | 500        | 1.0            |
| 500   | 700                             | 2,800                            | 100        | 0.2            | 500                                | 500                             | 2,000                            | 1,000      | 2.0            |
| 500   | 500                             | 2,000                            | 100        | 0.3            | 500                                | 500                             | 2,000                            | 500        | 1.5            |
| 500   | 500                             | 2,000                            | 100        | 0.3            | 500                                | 500                             | 2,000                            | 1,000      | 3.0            |
| 500   | 400                             | 1,600                            | 100        | 0.4            | 500                                | 400                             | 1,600                            | 500        | 2.0            |
| 500   | 400                             | 1,600                            | 100        | 1.2            | 500                                | 300                             | 1,200                            | 1,000      | 12.0           |
| 500   | 250                             | 1,000                            | 100        | 2.5            | 500                                | 250                             | 1,000                            | 1,000      | 25.0           |
| 500   | 100                             | 400                              | 100        | 5.0            | 500                                | 100                             | 400                              | 1,000      | 50.0           |
| 500   | 700                             | 2,800                            | 100        | 0.2            | 500                                | 500                             | 2,000                            | 500        | 1.0            |
| 500   | 700                             | 2,800                            | 100        | 0.2            | 500                                | 500                             | 2,000                            | 1,000      | 2.0            |
| 500   | 500                             | 2,000                            | 100        | 0.3            | 500                                | 500                             | 2,000                            | 1,000      | 1.5            |
| 500   | 500                             | 2,000                            | 100        | 0.3            | 500                                | 500                             | 2,000                            | 100        | 3.0            |
| 500   | 400                             | 1,600                            | 100        | 0.4            | 500                                | 400                             | 1,600                            | 500        | 2.0            |
| 500   | 400                             | 1,600                            | 100        | 1.2            | 500                                | 300                             | 1,200                            | 1,000      | 12.0           |
| 500   | 250                             | 1,000                            | 100        | 2.5            | 500                                | 250                             | 1,000                            | 1,000      | 25.0           |
| 500   | 100                             | 400                              | 100        | 5.0            | 500                                | 100                             | 400                              | 1,000      | 50.0           |
| 750   | 1,200                           | 4,600                            | 100        | 0.3            | 750                                | 700                             | 2,800                            | 500        | 1.5            |
| 750   | 1,200                           | 4,600                            | 100        | 0.4            | 750                                | 700                             | 2,800                            | 500        | 2.0            |
| 750   | 1,200                           | 4,600                            | 100        | 0.4            | 750                                | 700                             | 2,800                            | 1,000      | 4.0            |
| 750   | 1,200                           | 4,600                            | 100        | 2.5            | 750                                | 350                             | 1,400                            | 1,000      | 25.0           |
| 750   | 400                             | 1,600                            | 100        | 3.0            | 750                                | 350                             | 1,400                            | 1,000      | 30.0           |
| 750   | 250                             | 1,000                            | 100        | 4.06           | 750                                | 250                             | 1,000                            | 1,000      | 40.6           |

<sup>121)</sup> Linear modules on plain bearings require an aluminium shaft end support when connected to a motor. The technical values in the specifications are maximum values for each criterion, e.g. speed, stroke length etc.; they are not cumulative values. Suitability under consideration of the individual parameters for usage can be checked online at [www.igus.eu/linearmodule-finder](http://www.igus.eu/linearmodule-finder).

| Linear module |         |        |         |                            |                      |                                 |
|---------------|---------|--------|---------|----------------------------|----------------------|---------------------------------|
| Linear module | Shaft Ø | Thread | Pitch   | Lead screw<br>Self-locking | Carriage length      | Motor<br>connection<br>possible |
|               | [mm]    |        |         |                            | [mm]                 |                                 |
| SLW-16120     | 16      | TR     | 14x3    | +                          | 150 / 200 / 250      | +                               |
|               |         | TR     | 14x4    | +                          | 150 / 200 / 250      | +                               |
|               |         | DS     | 14x4    | +                          | 150 / 200 / 250      | +                               |
|               |         | DS     | 14x25   | -                          | 150 / 200 / 250      | +                               |
|               |         | DS     | 14x30   | -                          | 150 / 200 / 250      | +                               |
|               |         | DS     | 14x40.6 | -                          | 150 / 200 / 250      | +                               |
| SLW-2080      | 20      | TR     | 18x4    | +                          | 45 / 150 / 200 / 250 | +                               |
|               |         | DS     | 18x4    | +                          | 45 / 100 / 150 / 200 | +                               |
|               |         | TR     | 18x8P4  | +                          | 45 / 150 / 200 / 250 | +                               |
|               |         | DS     | 18x24   | -                          | 45 / 150 / 200 / 250 | +                               |
|               |         | DS     | 18x40   | -                          | 45 / 150 / 200 / 250 | +                               |
|               |         | DS     | 18x80   | -                          | 45 / 150 / 200 / 250 | +                               |
|               |         | DS     | 18x100  | -                          | 45 / 150 / 200 / 250 | +                               |
| SLW-25120     | 25      | DS     | 20x5    | -                          | 150 / 200 / 250      | +                               |
|               |         | DS     | 20x10   | -                          | 150 / 200 / 250      | +                               |
|               |         | DS     | 20x20   | -                          | 150 / 200 / 250      | +                               |
|               |         | DS     | 20x50   | -                          | 150 / 200 / 250      | +                               |
|               |         | DS     | 20x60   | -                          | 150 / 200 / 250      | +                               |
|               |         | DS     | 20x80   | -                          | 150 / 200 / 250      | +                               |
|               |         | DS     | 20x90   | -                          | 150 / 200 / 250      | +                               |
| SAW-0630      | 6       | TR     | 8x1.5   | +                          | 50 / 60 / 100        | +                               |
|               |         | DS     | 8x10    | -                          | 50 / 60 / 100        | +                               |
|               |         | DS     | 8x15    | -                          | 50 / 60 / 100        | +                               |
| SAW-0660      | 6       | TR     | 10x2    | +                          | 100                  | +                               |
|               |         | DS     | 10x2    | +                          | 100                  | +                               |
|               |         | DS     | 10x3    | -                          | 100                  | +                               |
|               |         | DS     | 10x12   | -                          | 100                  | +                               |
|               |         | DS     | 10x25   | -                          | 100                  | +                               |
|               |         | DS     | 10x50   | -                          | 100                  | +                               |
| SAW-1040      | 10      | TR     | 10x2    | +                          | 69 / 100 / 150       | +                               |
|               |         | DS     | 10x2    | +                          | 69 / 100 / 150       | +                               |
|               |         | TR     | 10x3    | +                          | 69 / 100 / 150       | +                               |
|               |         | DS     | 10x3    | -                          | 69 / 100 / 150       | +                               |
|               |         | TR     | 10x4    | +                          | 69 / 100 / 150       | +                               |
|               |         | DS     | 10x12   | -                          | 69 / 100 / 150       | +                               |
|               |         | DS     | 10x25   | -                          | 69 / 100 / 150       | +                               |
|               |         | DS     | 10x50   | -                          | 69 / 100 / 150       | +                               |

<sup>120)</sup> When configuring your linear module, we ask that you note the igus® specifications for maximum stroke lengths. The performance and load specifications shown above for all drive units are based exclusively on stroke lengths within the recommended values. Exceeding these can result in undesirable effects to the function such as increased wear and noise. Belt or lead screw contact cannot be excluded, and the rated performance and load specifications may not be attainable.

| Lead screw with plain bearing support <sup>121)</sup> |                                  |                                   |            |                | Ball bearing supported lead screws |                                  |                                   |            |                |
|---|----------------------------------|-----------------------------------|------------|----------------|------------------------------------|----------------------------------|-----------------------------------|------------|----------------|
| Max. stroke length <sup>120)</sup>                    | Max. static, axial load capacity | Max. static, radial load capacity | Max. speed | Max. feed rate | Max. stroke length <sup>120)</sup> | Max. static, axial load capacity | Max. static, radial load capacity | Max. speed | Max. feed rate |
| [mm]  | [N]                              | [N]                               | [rpm]      | [m/min]        | [mm]                               | [N]                              | [N]                               | [rpm]      | [m/min]        |
| 750   | 1,200                            | 4,600                             | 100        | 0.3            | 750                                | 700                              | 2,800                             | 500        | 1.5            |
| 750   | 1,200                            | 4,600                             | 100        | 0.4            | 750                                | 700                              | 2,800                             | 500        | 2.0            |
| 750   | 1,200                            | 4,600                             | 100        | 0.4            | 750                                | 700                              | 2,800                             | 1,000      | 4.0            |
| 750   | 600                              | 2,400                             | 100        | 2.5            | 750                                | 350                              | 1,400                             | 1,000      | 25.0           |
| 750   | 600                              | 1,600                             | 100        | 3.0            | 750                                | 350                              | 1,400                             | 1,000      | 30.0           |
| 750   | 250                              | 1,000                             | 100        | 4.06           | 750                                | 250                              | 1,400                             | 1,000      | 40.6           |
| 900   | 1,600                            | 6,400                             | 100        | 0.4            | 900                                | 1,250                            | 5,000                             | 500        | 2.0            |
| 900   | 1,600                            | 6,400                             | 100        | 0.4            | 900                                | 1,000                            | 4,000                             | 500        | 2.0            |
| 900   | 1,200                            | 4,800                             | 100        | 0.8            | 900                                | 1,200                            | 4,800                             | 500        | 2.0            |
| 900   | 800                              | 3,200                             | 100        | 2.4            | 900                                | 800                              | 3,200                             | 1,000      | 24.0           |
| 900   | 500                              | 2,000                             | 100        | 4.0            | 900                                | 500                              | 2,000                             | 1,000      | 40.0           |
| 900   | 250                              | 1,000                             | 100        | 8.0            | 900                                | 250                              | 1,000                             | 900        | 72.0           |
| 900   | 200                              | 800                               | 100        | 10.0           | 900                                | 200                              | 800                               | 750        | 75.0           |
| -   | -                                | -                                 | -          | -              | 1,000                              | 1,500                            | 6,000                             | 1,000      | 5.0            |
| -   | -                                | -                                 | -          | -              | 1,000                              | 1,200                            | 4,800                             | 1,000      | 10.0           |
| -   | -                                | -                                 | -          | -              | 1,000                              | 1,000                            | 4,000                             | 1,000      | 20.0           |
| -   | -                                | -                                 | -          | -              | 1,000                              | 700                              | 2,800                             | 1,000      | 50.0           |
| -   | -                                | -                                 | -          | -              | 1,000                              | 600                              | 2,800                             | 1,000      | 60.0           |
| -   | -                                | -                                 | -          | -              | 1,000                              | 400                              | 1,600                             | 1,000      | 80.0           |
| -   | -                                | -                                 | -          | -              | 1,000                              | 300                              | 1,200                             | 1,000      | 90.0           |
| 1,000   | 2,500                            | 10,000                            | 100        | 0.5            | 1,000                              | 1,500                            | 6,000                             | 500        | 2.5            |
| -   | -                                | -                                 | -          | -              | 300                                | 100                              | 200                               | 500        | 0.75           |
| -   | -                                | -                                 | -          | -              | 300                                | 100                              | 200                               | 1,000      | 10.0           |
| -   | -                                | -                                 | -          | -              | 300                                | 100                              | 200                               | 1,000      | 15.0           |
| -   | -                                | -                                 | -          | -              | 500                                | 100                              | 400                               | 500        | 1.0            |
| -   | -                                | -                                 | -          | -              | 500                                | 500                              | 2,000                             | 1,000      | 2.0            |
| -   | -                                | -                                 | -          | -              | 500                                | 500                              | 2,000                             | 1,000      | 3.0            |
| -   | -                                | -                                 | -          | -              | 500                                | 100                              | 400                               | 1,000      | 12.0           |
| -   | -                                | -                                 | -          | -              | 500                                | 100                              | 400                               | 1,000      | 25.0           |
| -   | -                                | -                                 | -          | -              | 500                                | 100                              | 400                               | 1,000      | 3.0            |
| -   | -                                | -                                 | -          | -              | 500                                | 500                              | 2,000                             | 500        | 1.0            |
| -   | -                                | -                                 | -          | -              | 500                                | 500                              | 2,000                             | 1,000      | 2.0            |
| -   | -                                | -                                 | -          | -              | 500                                | 500                              | 2,000                             | 500        | 1.5            |
| -   | -                                | -                                 | -          | -              | 500                                | 500                              | 2,000                             | 1,000      | 3.0            |
| -   | -                                | -                                 | -          | -              | 500                                | 400                              | 1,600                             | 500        | 2.0            |
| -   | -                                | -                                 | -          | -              | 500                                | 300                              | 1,200                             | 1,000      | 12.0           |
| -   | -                                | -                                 | -          | -              | 500                                | 250                              | 1,000                             | 1,000      | 25.0           |
| -   | -                                | -                                 | -          | -              | 500                                | 100                              | 400                               | 1,000      | 50.0           |

<sup>121)</sup> Linear modules on plain bearings require an aluminium shaft end support when connected to a motor. The technical values in the specifications are maximum values for each criterion, e.g. speed, stroke length etc.; they are not cumulative values. Suitability under consideration of the individual parameters for usage can be checked online at [www.igus.eu/linearmodule-finder](http://www.igus.eu/linearmodule-finder).



| Linear module |         |        |           |                            |                 |                                 |
|---------------|---------|--------|-----------|----------------------------|-----------------|---------------------------------|
| Linear module | Shaft Ø | Thread | Pitch     | Lead screw<br>Self-locking | Carriage length | Motor<br>connection<br>possible |
|               | [mm]    |        |           |                            | [mm]            |                                 |
| SAW-1080      | 10      | TR     | 12x3      | +                          | 100 / 150       | +                               |
|               |         | TR     | 12x6P3    | +                          | 100 / 150       | +                               |
|               |         | DS     | 12x5      | +                          | 100 / 150       | +                               |
|               |         | DS     | 12x25     | -                          | 100 / 150       | +                               |
| SAW-1660      | 16      | TR     | 14x3      | +                          | 100 / 150 / 200 | +                               |
|               |         | TR     | 14x4      | +                          | 100 / 150 / 200 | +                               |
|               |         | DS     | 14x4      | +                          | 100 / 150 / 200 | +                               |
|               |         | DS     | 14x25     | -                          | 100 / 150 / 200 | +                               |
|               |         | DS     | 14x30     | -                          | 100 / 150 / 200 | +                               |
|               |         | DS     | 14x40.6   | -                          | 100 / 150 / 200 | +                               |
| SLT-0412      | 5       | TR     | 8x1,5     | +                          | 38              | +                               |
|               |         | DS     | 8x10      | -                          | 38              | +                               |
|               |         | DS     | 8x15      | -                          | 38              | +                               |
| SLT-0415      | 10      | TR     | 12x3      | +                          | 45              | +                               |
|               |         | TR     | 12x6P3    | +                          | 45              | +                               |
|               |         | DS     | 12x5      | +                          | 45              | +                               |
|               |         | DS     | 12x25     | -                          | 45              | +                               |
| SLN(V)-27     | 27      | M      | M5x0.8    | +                          | 35              | +                               |
|               |         | DS     | 5x5       | -                          | 35              | +                               |
|               |         | DS     | 6.35x2.54 | -                          | 35              | +                               |
|               |         | DS     | 6.35x5.08 | -                          | 35              | +                               |
|               |         | DS     | 6.35x12.7 | -                          | 35              | +                               |
|               |         | DS     | 6.35x25.4 | -                          | 35              | +                               |
| SHTP-01-06    | 6       | M      | M8x1.25   | +                          | 45              | +                               |
| SHTP-01-10    | 10      | TR     | 8x1.5     | +                          | 26              | +                               |
| SHTP-01-12    | 12      | TR     | 10x2      | +                          | 55              | +                               |
| SHTP-02-12    | 12      | TR     | 10x2      | +                          | 55              | -                               |
| SET-12        | 12      | M      | M4x0.7    | +                          | 30              | -                               |
| SET-25        | 25      | TR     | 10x2      | +                          | 55              | -                               |
| SET-30        | 30      | TR     | 12x3      | +                          | 55              | -                               |

<sup>120)</sup> When configuring your linear module, we ask that you note the igus® specifications for maximum stroke lengths. The performance and load specifications shown above for all drive units are based exclusively on stroke lengths within the recommended values. Exceeding these can result in undesirable effects to the function such as increased wear and noise. Belt or lead screw contact cannot be excluded, and the rated performance and load specifications may not be attainable.

| Lead screw with plain bearing support <sup>121)</sup> |                                 |                                  |            |                | Ball bearing supported lead screws |                                 |                                  |            |                |
|---|---------------------------------|----------------------------------|------------|----------------|------------------------------------|---------------------------------|----------------------------------|------------|----------------|
| Max. stroke length <sup>120)</sup>                    | Max. static axial load capacity | Max. static radial load capacity | Max. speed | Max. feed rate | Max. stroke length <sup>120)</sup> | Max. static axial load capacity | Max. static radial load capacity | Max. speed | Max. feed rate |
| [mm]  | [N]                             | [N]                              | [rpm]      | [m/min]        | [mm]                               | [N]                             | [N]                              | [rpm]      | [m/min]        |
| -   | -                               | -                                | -          | -              | 750                                | 750                             | 2,000                            | 500        | 1.5            |
| -   | -                               | -                                | -          | -              | 750                                | 400                             | 1,600                            | 500        | 1.5            |
| -   | -                               | -                                | -          | -              | 750                                | 300                             | 1,200                            | 1,000      | 1.5            |
| -   | -                               | -                                | -          | -              | 750                                | 200                             | 800                              | 300        | 25.0           |
| -   | -                               | -                                | -          | -              | 750                                | 700                             | 2,800                            | 1,000      | 4.5            |
| -   | -                               | -                                | -          | -              | 750                                | 700                             | 2,800                            | 1,000      | 6.0            |
| -   | -                               | -                                | -          | -              | 750                                | 700                             | 2,800                            | 1,000      | 6.0            |
| -   | -                               | -                                | -          | -              | 750                                | 350                             | 1,400                            | 400        | 10.0           |
| -   | -                               | -                                | -          | -              | 750                                | 350                             | 1,400                            | 400        | 12.0           |
| -   | -                               | -                                | -          | -              | 750                                | 250                             | 1,000                            | 400        | 16.24          |
| -   | -                               | -                                | -          | -              | 300                                | 100                             | 400                              | 1,000      | 1.5            |
| -   | -                               | -                                | -          | -              | 300                                | 25                              | 100                              | 600        | 6.0            |
| -   | -                               | -                                | -          | -              | 300                                | 25                              | 100                              | 600        | 9.0            |
| -   | -                               | -                                | -          | -              | 600                                | 200                             | 800                              | 1,000      | 4.5            |
| -   | -                               | -                                | -          | -              | 600                                | 100                             | 400                              | 750        | 4.5            |
| -   | -                               | -                                | -          | -              | 600                                | 100                             | 400                              | 750        | 3.75           |
| -   | -                               | -                                | -          | -              | 600                                | 100                             | 400                              | 750        | 18.75          |
| 300   | 10                              | 40                               | 100        | 0.08           | 300                                | 10                              | 40                               | 250        | 0.2            |
| 250   | 10                              | 40                               | 100        | 0.5            | 250                                | 10                              | 40                               | 100        | 0.5            |
| 300   | 10                              | 40                               | 100        | 0.254          | 300                                | 10                              | 40                               | 500        | 1.27           |
| 300   | 10                              | 40                               | 100        | 0.508          | 300                                | 10                              | 40                               | 500        | 2.54           |
| 300   | 10                              | 40                               | 100        | 1.27           | 300                                | 10                              | 40                               | 500        | 6.35           |
| 300   | 10                              | 40                               | 100        | 2.54           | 300                                | 10                              | 40                               | 500        | 12.7           |
| 300   | 50                              | 50                               | 100        | 0.125          | -                                  | -                               | -                                | -          | -              |
| 300   | 100                             | 200                              | 100        | 0.15           | -                                  | -                               | -                                | -          | -              |
| 500   | 200                             | 400                              | 100        | 0.2            | -                                  | -                               | -                                | -          | -              |
| 500   | 200                             | 800                              | 100        | 0.2            | -                                  | -                               | -                                | -          | -              |
| 100   | 10                              | 20                               | 100        | 0.07           | -                                  | -                               | -                                | -          | -              |
| 500   | 150                             | 300                              | 100        | 0.2            | -                                  | -                               | -                                | -          | -              |
| 750   | 200                             | 400                              | 100        | 0.3            | -                                  | -                               | -                                | -          | -              |

<sup>121)</sup> Linear modules on plain bearings require an aluminium shaft end support when connected to a motor. The technical values in the specifications are maximum values for each criterion, e.g. speed, stroke length etc.; they are not cumulative values. Suitability under consideration of the individual parameters for usage can be checked online at [www.igus.eu/linearmodule-finder](http://www.igus.eu/linearmodule-finder).

|         |        | dryspin® thread sizes |      |        |           |           |           |           |           |
|---------|--------|-----------------------|------|--------|-----------|-----------|-----------|-----------|-----------|
|         |        | 5x5                   | 5x10 | 6.35x1 | 6.35x2.54 | 6.35x5.08 | 6.35x6.35 | 6.35x12.7 | 6.35x25.4 |
| SHT (C) | -08    |                       |      | ●      | ●         | ●         | ●         | ●         | ●         |
|         | -12    |                       |      |        |           |           |           |           |           |
|         | -20    |                       |      |        |           |           |           |           |           |
|         | -30    |                       |      |        |           |           |           |           |           |
| SLW     | -06    |                       |      |        |           |           |           |           |           |
|         | -10    |                       |      |        |           |           |           |           |           |
|         | -1660  |                       |      |        |           |           |           |           |           |
|         | -16120 |                       |      |        |           |           |           |           |           |
|         | -20    |                       |      |        |           |           |           |           |           |
| SAW     | -25    |                       |      |        |           |           |           |           |           |
|         | -0630  |                       |      |        |           |           |           |           |           |
|         | -0660  |                       |      |        |           |           |           |           |           |
|         | -1040  |                       |      |        |           |           |           |           |           |
|         | -1080  |                       |      |        |           |           |           |           |           |
| SLN     | -16    |                       |      |        |           |           |           |           |           |
|         | -27    | ●                     | ●    | ●      | ●         | ●         | ●         | ●         | ●         |
| SLNV    | -27    | ●                     | ●    | ●      | ●         | ●         | ●         | ●         | ●         |
|         | -27    | ●                     | ●    | ●      | ●         | ●         | ●         | ●         | ●         |
| SHTP    | -0112  |                       |      |        |           |           |           |           |           |
|         | -04-12 |                       |      |        |           |           |           |           |           |
| SLT     | -04-15 |                       |      |        |           |           |           |           |           |
|         | -04-15 |                       |      |        |           |           |           |           |           |

● = dryspin® thread  
● = Upon request

|      |        | 8x8     | 8x10 | 8x15 | 8x24 | 8x40 | 10x2 | 10x3 | 10x12 | 10x25 | 10x50 | 12x3 | 12x5 |
|------|--------|---------|------|------|------|------|------|------|-------|-------|-------|------|------|
|      |        | SHT (C) | -08  |      |      |      |      |      | ●     | ●     | ●     | ●    |      |
| -12  |        |         |      |      |      |      | ●    | ●    | ●     | ●     |       |      |      |
| SLW  | -06    | ●       | ●    | ●    | ●    | ●    |      |      |       |       |       |      |      |
|      | -10    |         |      |      |      |      | ●    | ●    | ●     | ●     |       |      |      |
|      | -1660  |         |      |      |      |      |      |      |       |       |       |      |      |
|      | -16120 |         |      |      |      |      |      |      |       |       |       |      |      |
|      | -20    |         |      |      |      |      |      |      |       |       |       |      |      |
| SAW  | -25    |         |      |      |      |      |      |      |       |       |       |      |      |
|      | -0630  | ●       | ●    | ●    | ●    | ●    |      |      |       |       |       |      |      |
|      | -0660  |         |      |      |      |      | ●    | ●    | ●     | ●     |       |      |      |
|      | -1040  |         |      |      |      |      | ●    | ●    | ●     | ●     |       |      |      |
|      | -1080  |         |      |      |      |      |      |      |       |       |       | ●    | ●    |
| SLN  | -16    |         |      |      |      |      |      |      |       |       |       |      |      |
|      | -27    | ●       | ●    | ●    | ●    | ●    |      |      |       |       |       |      |      |
| SLNV | -27    | ●       | ●    | ●    | ●    | ●    |      |      |       |       |       |      |      |
|      | -27    | ●       | ●    | ●    | ●    | ●    |      |      |       |       |       |      |      |
| SHTP | -0112  |         |      |      |      |      |      | ●    | ●     | ●     |       |      |      |
|      | -04-12 | ●       | ●    | ●    | ●    | ●    |      |      |       |       |       |      |      |
| SLT  | -04-15 |         |      |      |      |      |      |      |       |       |       | ●    | ●    |
|      | -04-15 |         |      |      |      |      |      |      |       |       |       | ●    | ●    |





# drylin® drive technology | Technical options

In addition to the standard configurations, drylin® drives offer numerous solutions for the many requirements of different applications.

The following options can be configured online with the SHT configurator:  
[www.igus.eu/sht-configurator](http://www.igus.eu/sht-configurator)

## Pre-load (PL)

The axial preload reduces the backlash of the system. Positioning and repeatability can be optimised. The required drive torque increases only slightly.



For SHT, SLW and SAW linear modules

## Zero-backlash (ZB)

Self-adjusting zero-backlash lead screw nuts are available for SHT modules in sizes 08 and 12. For movements that require repeatability and which are implemented through high helix thread, the ZB function provides a minimal lifelong backlash.

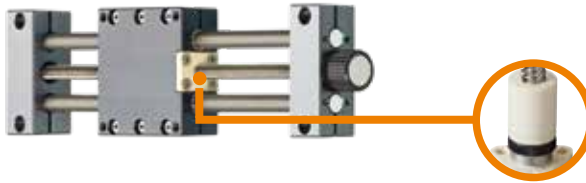

## Linear modules with ball-bearing mounted lead screw

The SHT and SLW linear modules with ball bearing supported lead screws give reduced vibration, and increased dynamic capability. These are also suitable for applications with motor drives.



## Shaft materials

When using linear modules of the SHT series, you can choose a shaft material from steel, stainless steel, or hard-anodised aluminium (standard). The short delivery time and excellent coefficient of friction and wear make the aluminium version the most common choice.



## Lead screw materials

All drylin® linear modules can be delivered with self-locking trapezoidal steel and stainless steel lead screws; upon request, these can also be made from hard-anodised aluminium. The SHT and SLW series can also be configured with dryspin® high helix lead technology. This allows for much higher pitches and drive speeds, but without the self-locking feature.

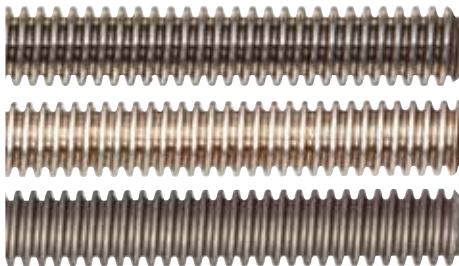

## Bearing materials

The bearing surfaces of the drylin® drive units are equipped with lubrication and maintenance-free igus® high performance polymers. Options include materials for high temperature application up to +180°C (iglidur® X, SHT-ES series), and also for FDA-compliant environments (iglidur® A180).



## Complete solutions made of stainless steel

The use of AISI 316Ti and AISI 304 makes of the guides resistant to seawater and chemical contact corrosion. The guide shafts are also made from AISI 316Ti.

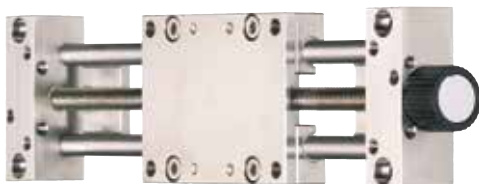

# drylin® drive technology | Technical options

## Linear modules with several carriages

All drylin® linear modules can be configured with multiple carriages. The short carriages from the SHTC series are perfectly suited for this. The second (or additional) carriage can be installed as a freely moving unit without lead screw, or as a fixed unit with its own trapezoidal lead screw nut.



Online customer drawing

► [www.igus.eu/customerdrawing](http://www.igus.eu/customerdrawing)

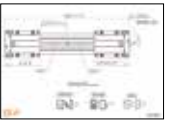

## Right/left opposite drive

In addition to the standard right-handed lead screws, left-hand lead screws and opposite drive lead screws can also be used. This option often used in format adjustments can be specified for all diameters and types. Also available as a multi-carriage system or with right/left opposite drive.

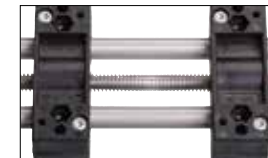

Online customer drawing

► [www.igus.eu/customerdrawing](http://www.igus.eu/customerdrawing)

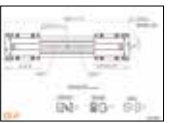

## Linear axes with motor: [www.igus.eu/drylinE-finder](http://www.igus.eu/drylinE-finder)

### Linear modules with motor

Several drylin® drive units are compatible with the drylin® modular kit. As linear axes, they can be easily and quickly configured directly to the matching igus® stepper motors, power cables and proximity switches - assembled and tested from one source.

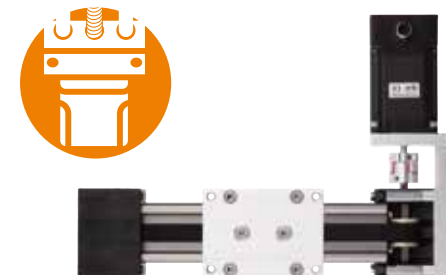

## More options:

### Adjustable radial clearance

The "turn to fit" feature allows individual clearance adjustment by hand. The adjustment is done in 0.01-mm increments and cannot be triggered unintentionally during the operation (SLW series 10-20).



For SLW and SAW linear modules

For SHT linear modules

### Fast Forward (FF)

SHT linear modules and SHTP plastic linear modules with quick-release mechanism offer a combination of accurate positioning and fast manual adjustment.

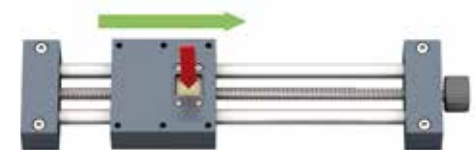

### drylin® SLW "Stop and Go"

This additional function for linear carriages enables the use of an unlimited number of carriages on one guide - controlled by only one lead screw. The connection to the lead screw is engaged or released via the button.

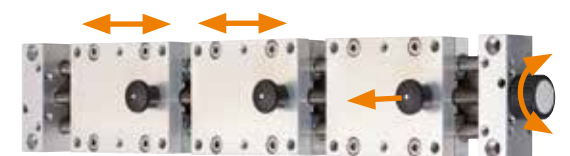

### XY-tables

The SHT and SLW linear modules can also be configured as XY tables. XY adjustments can therefore be given with a single unit.

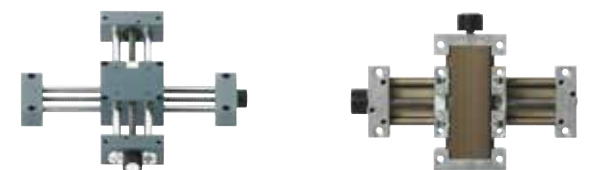



drylin® linear modules have been developed for position settings of all types. The linear setting is achieved by means of trapezoidal lead screws that can be operated manually or by motor. The maximum linear continuous speed is 1.6m/min depending on thread pitch and load. The suitability of the lead screw linear units for an application can be checked using the graphs below.



## HORIZONTAL

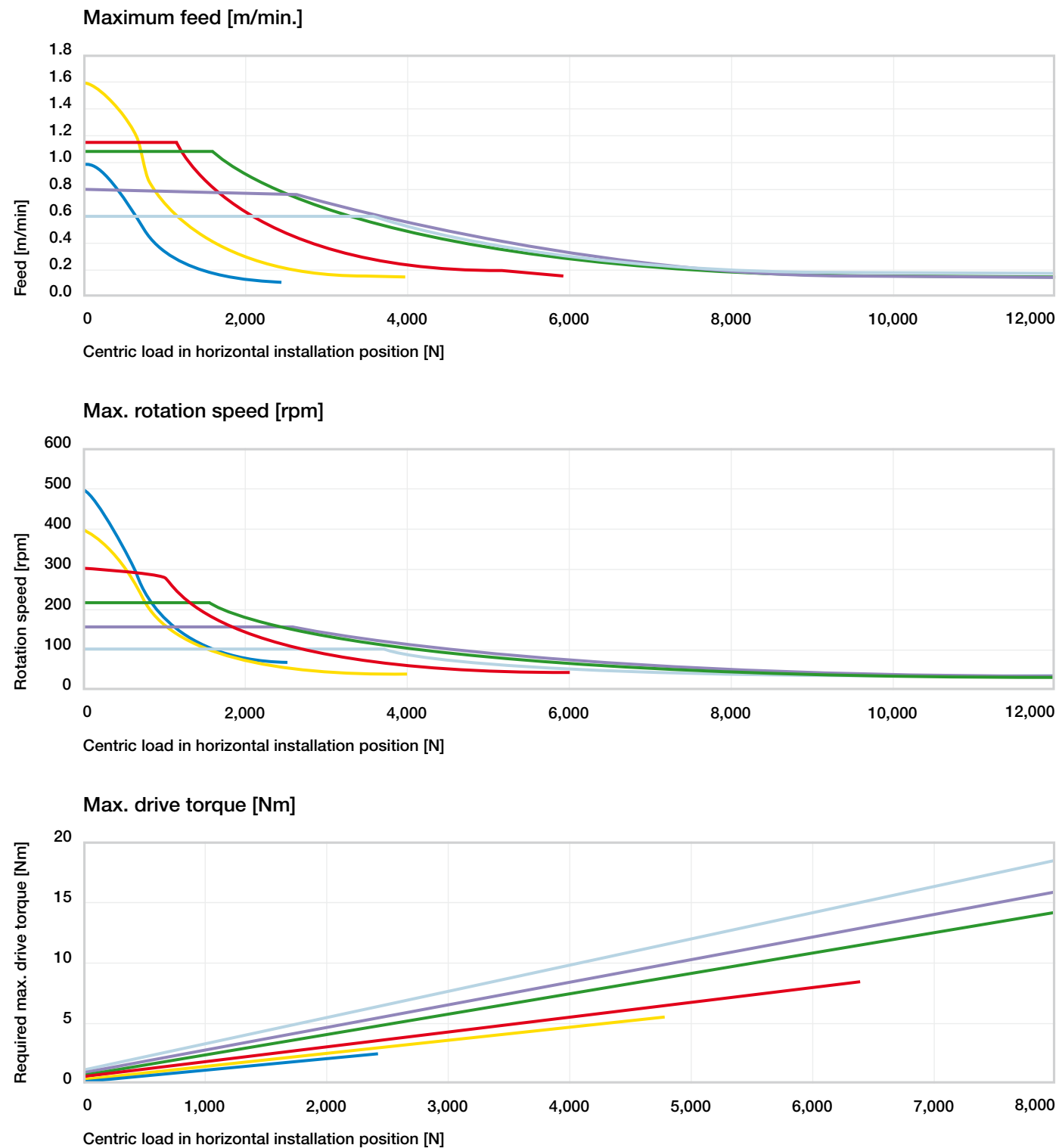

The following trapezoidal lead screw drive sizes are used in SHT, SLW and SET linear modules:

- **Tr10x2:** SHT-12, SHTC-12, SHTP-12, SLW-1040, SLW-1080, SLW-1040-ES, SET-25
- **Tr14x4:** SLW-1660
- **Tr18x4:** SHT-20, SHTC-20, SLW-2080
- **Tr24x5:** SHT-30, SHTC-30, SLW-25120
- **Tr26x5:** SHTC-40
- **Tr30x6:** SHTC-50



## VERTICAL

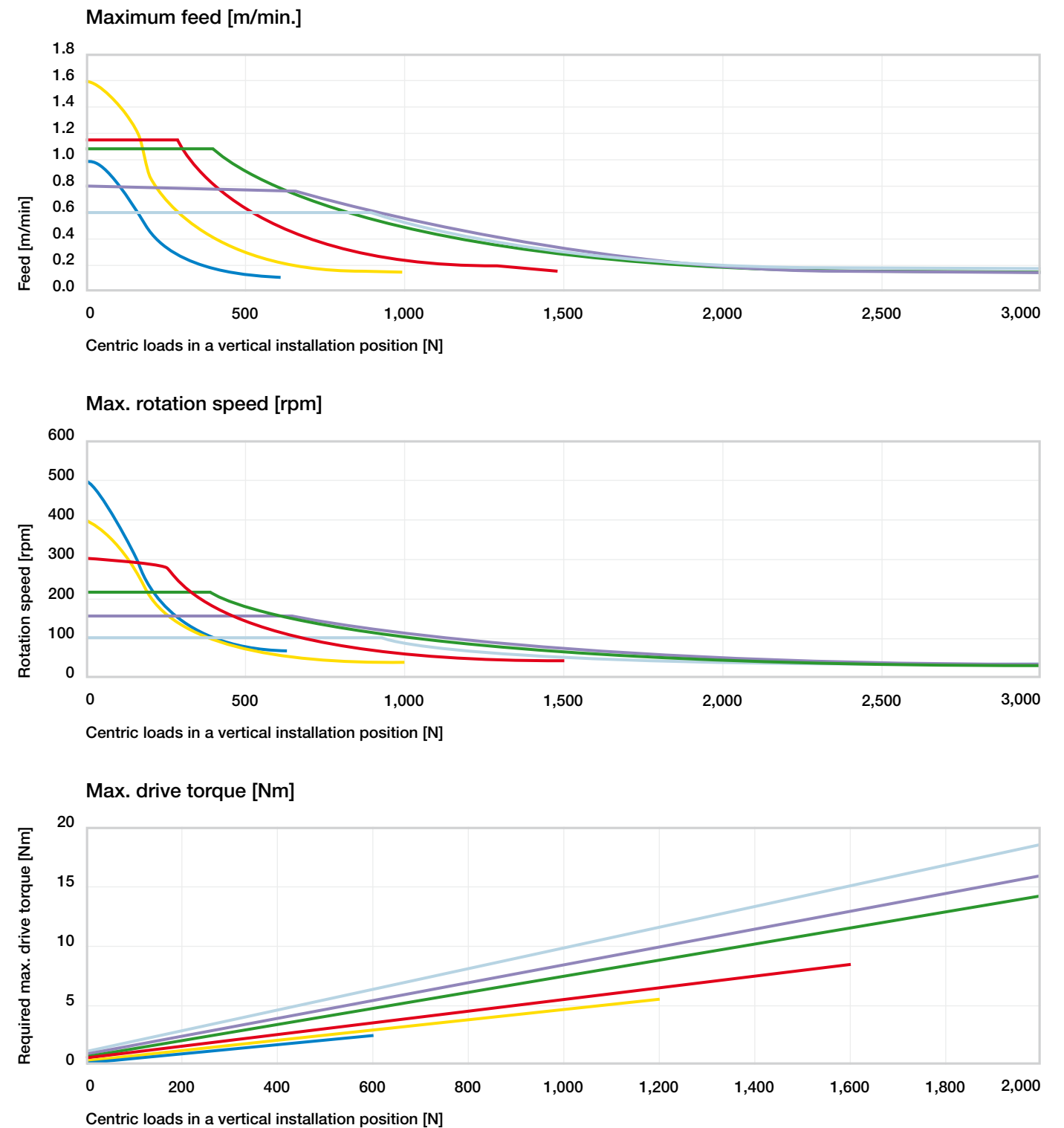

 Example configurations:

drylin® SHT-12, Tr10x2



With machined end Ø 6h9,  
17mm length  
DL-SHT-0926, 250mm stroke  
DL-SHT-0927, 500mm stroke

With position indicator, lead screw  
clamp and hand wheel  
DL-SHT-0928, 250mm stroke  
DL-SHT-0929, 500mm stroke

drylin® SLW-1040, Tr10x2



With machined end Ø 6h9,  
17mm length  
DL-SLW-0549, 250mm stroke  
DL-SLW-0550, 500mm stroke

With position indicator, lead screw  
clamp and hand wheel  
DL-SLW-0551, 250mm stroke  
DL-SLW-0552, 500mm stroke

drylin® SAW-0660, Ds10x25



With machined end Ø 6h9,  
15mm length  
DL-SAW-0085, 100mm stroke  
DL-SAW-0086, 500mm stroke

drylin® ZLW-0660-S



Toothed belt axis ZLW-0660-S  
DL-ZLW-0709, 250mm stroke

Toothed belt axis ZLW-1080-S  
DL-ZLW-0711, 500mm stroke  
DL-ZLW-00712, 1,000mm stroke

drylin® SAW-0630, Tr8x1.5



With NEMA17 stepper motor  
with stranded wires  
DLE-SA-0004, 250mm stroke

SAW-1040 linear module, Tr10x2  
With NEMA23 stepper motor  
with stranded wires  
DLE-SA-0005, 500mm stroke

drylin® ZLW-1040-B



With NEMA23 stepper motor  
with stranded wires  
DLE-SA-0002, 500mm stroke

Toothed belt axis ZLW-1080-S  
With NEMA23XL stepper motor  
with stranded wires  
DLE-SA-0003, 1,000mm stroke

 More information  
▶ [www.igus.eu/drylin-express](http://www.igus.eu/drylin-express)

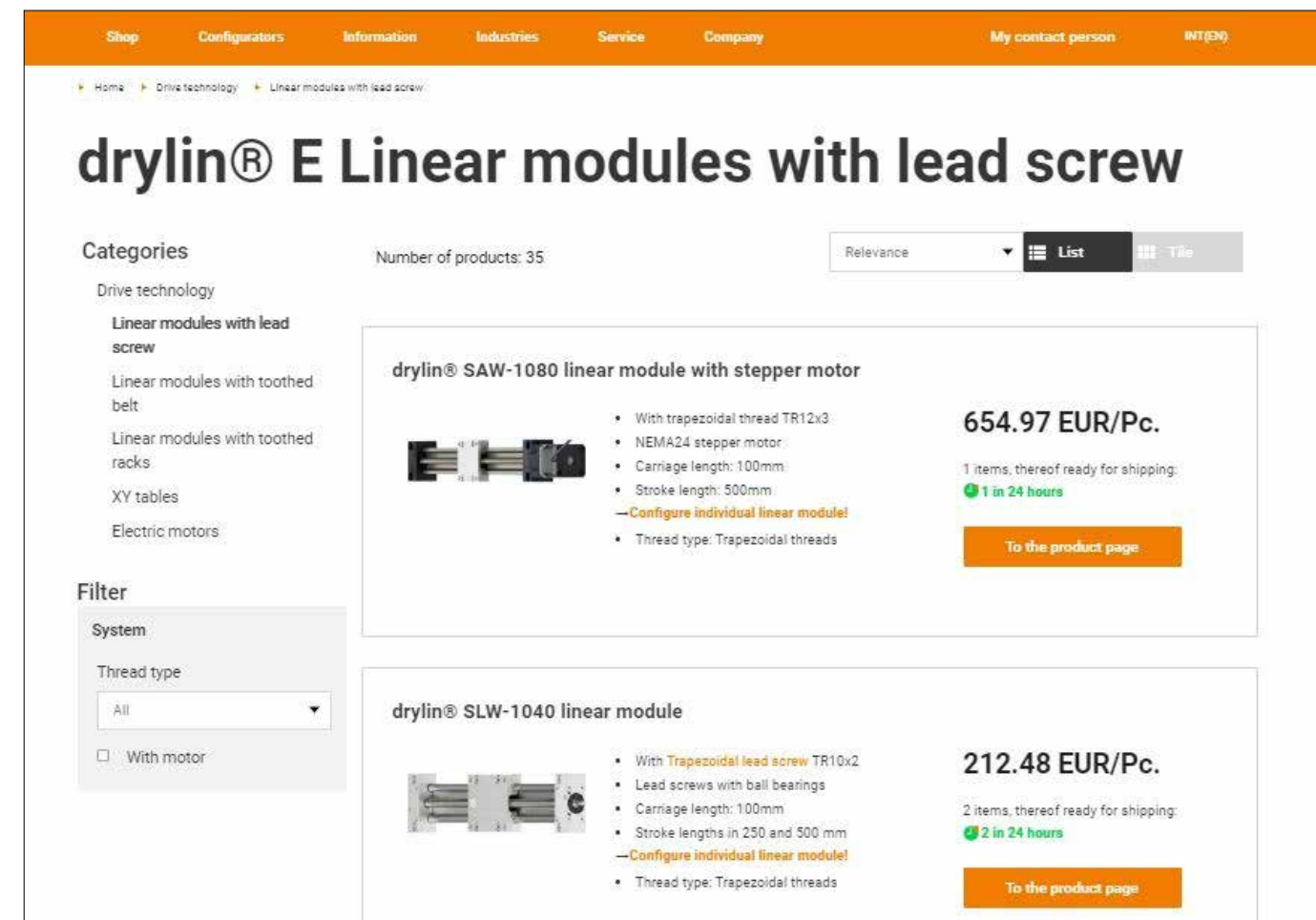

The screenshot shows the 'drylin® E Linear modules with lead screw' product page. It features a navigation bar with 'Shop', 'Configurators', 'Information', 'Industries', 'Service', and 'Company'. The main content area includes a breadcrumb trail, a title, and a list of products. Two products are highlighted:

- drylin® SAW-1080 linear module with stepper motor**: 654.97 EUR/Pc. 1 item, thereof ready for shipping: 1 in 24 hours.
- drylin® SLW-1040 linear module**: 212.48 EUR/Pc. 2 items, thereof ready for shipping: 2 in 24 hours.

Each product listing includes a small image, a list of specifications (e.g., thread type, carriage length, stroke length), and a 'Configure individual linear module!' link. A filter sidebar on the left allows users to filter by 'System', 'Thread type', and 'With motor'.

### Linear modules with just one click

- Simple ordering from the online shop:  
ready-to-connect linear modules and linear axes
- Two defined stroke lengths for each system
- With drive pins for manual and electric drive
- Ready-to-install with lead screw clamp, position indicator, hand wheel for fast adjustments or NEMA stepper motor.

 More information and prices online  
▶ [www.igus.eu/linear-module-shop](http://www.igus.eu/linear-module-shop)

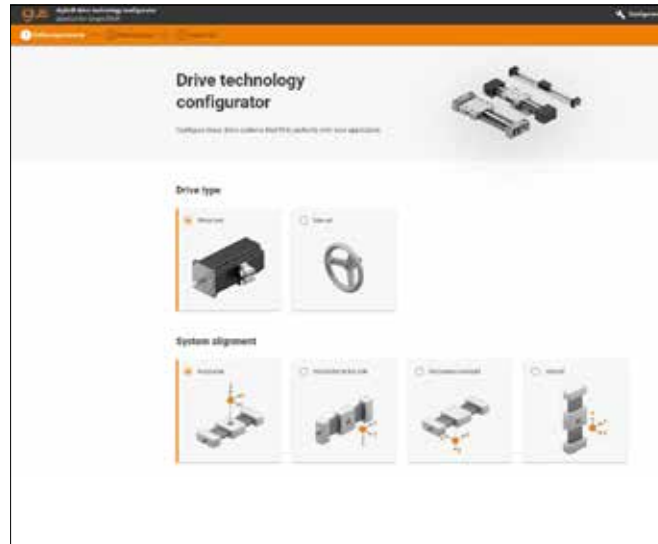

**Complete drive technology configurable with or without motor**

After you have selected your application parameters, the product finder shows an overview of the linear systems and the motors that are suitable. The product finder calculates the individual price of the linear axis as well as the utilisation rate of the motors and the service life in strokes. With just a few clicks, you can put together a complete linear axis including motor, connection cables and built-on parts.



► [www.igus.eu/linearmodule-configurator](http://www.igus.eu/linearmodule-configurator)

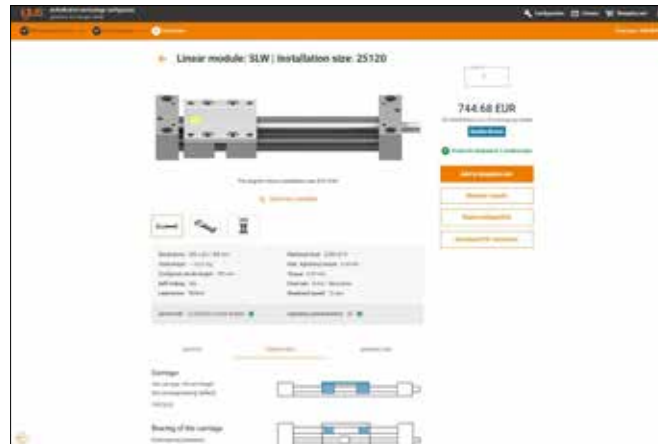

**Product finder for drylin® linear module**

Whether on laptop, pad or smart phone, selecting the right linear module is now very convenient and easy. Simply select the right system with a few technical parameters and the desired stroke length.



► [www.igus.eu/linear-module-product-finder](http://www.igus.eu/linear-module-product-finder)

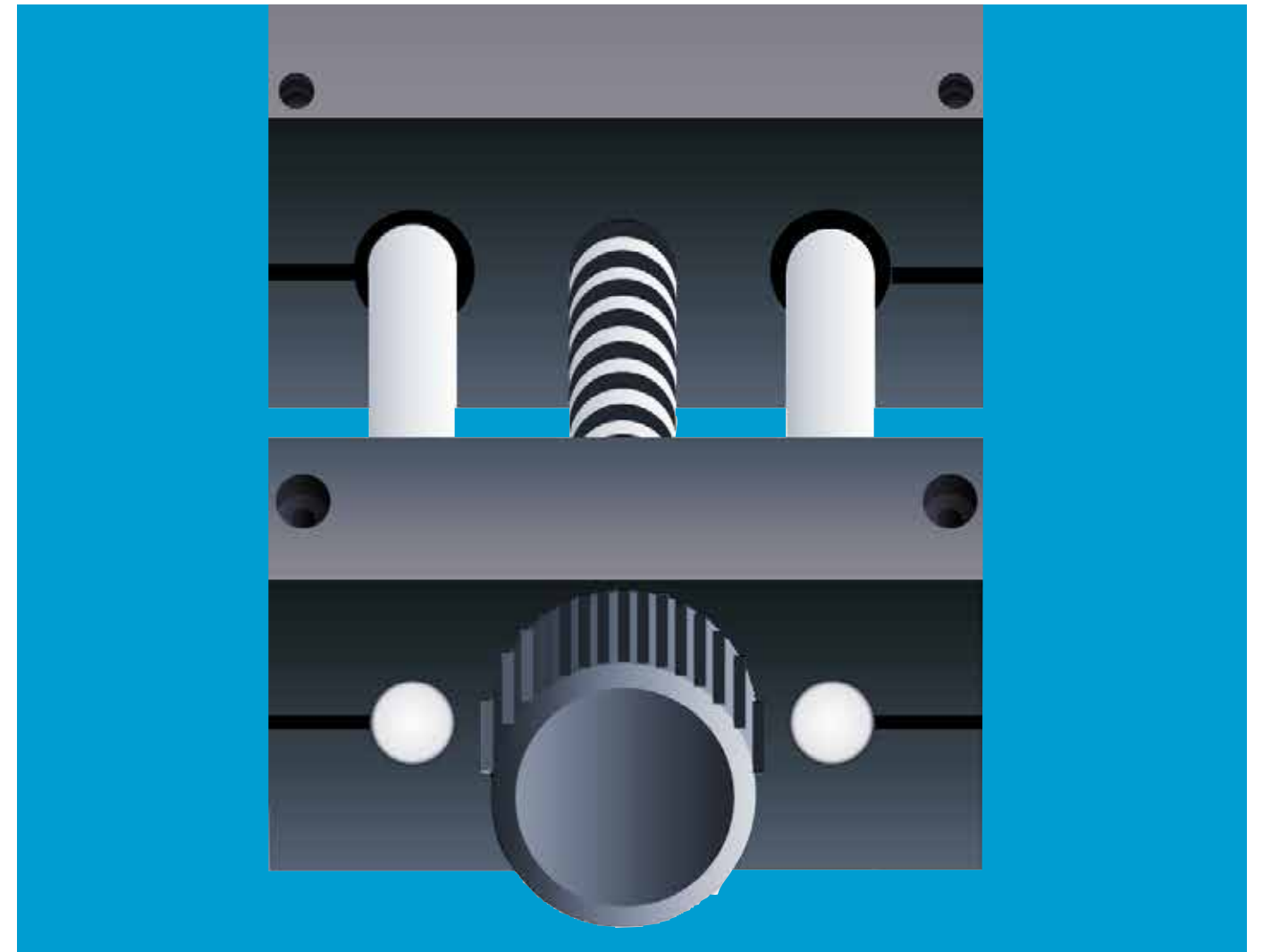
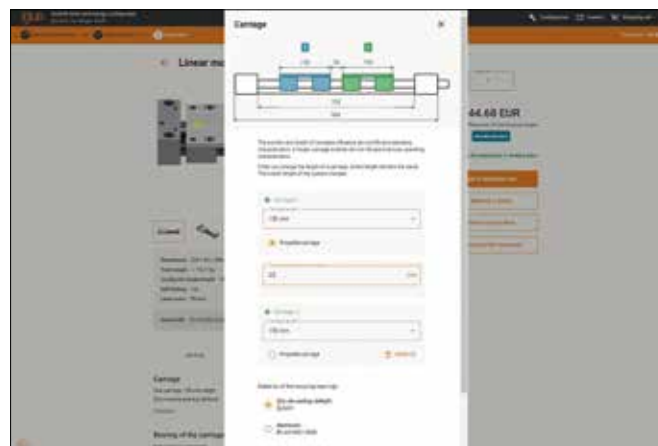

# drylin® drive technology - SHT linear modules

Drive: trapezoidal or high-helix lead screw

Ball-bearing mounted lead screw drives for higher dynamic forces

Lead screws made from steel, stainless steel or aluminium

Carriage in either quad block or compact design

Configurable online





Robust and precise

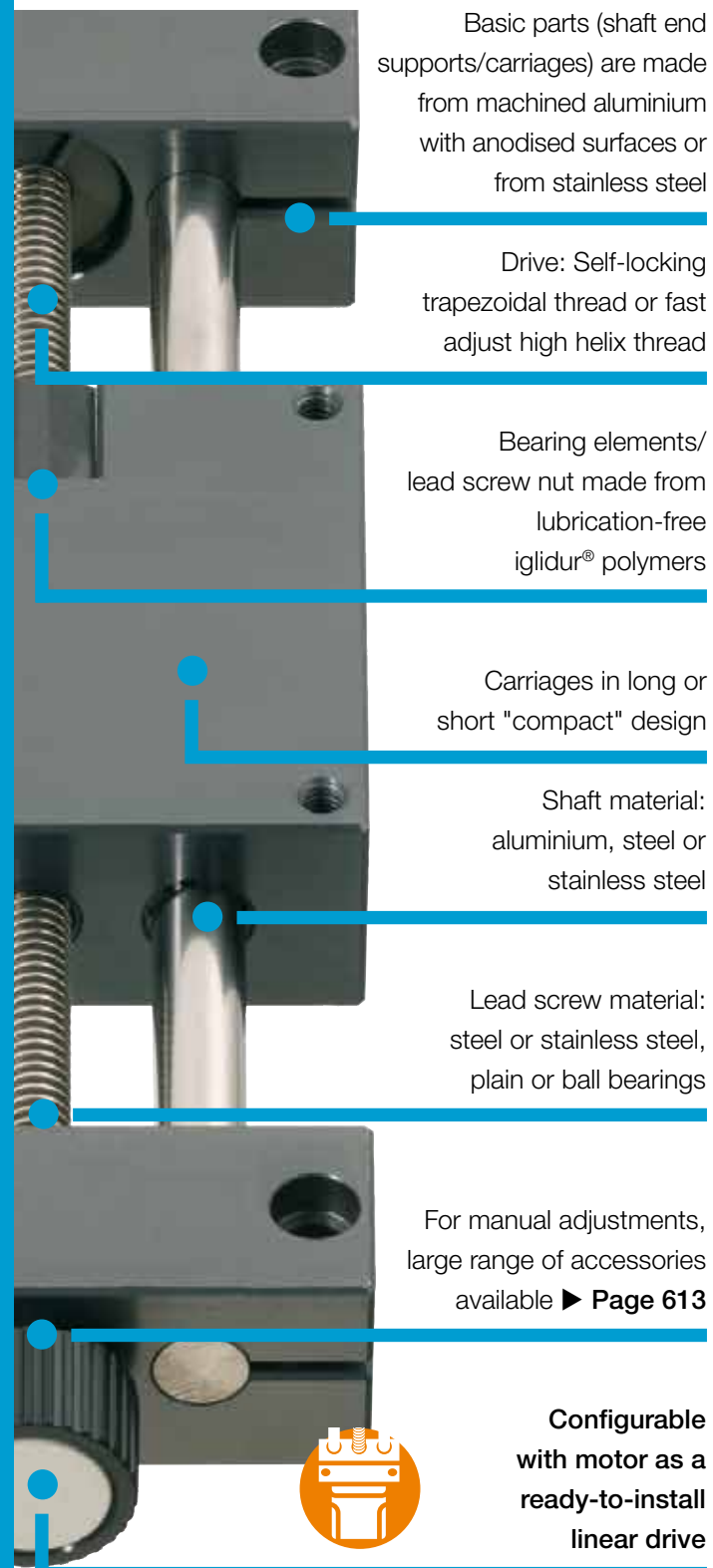

Basic parts (shaft end supports/carriages) are made from machined aluminium with anodised surfaces or from stainless steel

Drive: Self-locking trapezoidal thread or fast adjust high helix thread

Bearing elements/lead screw nut made from lubrication-free iglidur® polymers

Carriages in long or short "compact" design

Shaft material: aluminium, steel or stainless steel

Lead screw material: steel or stainless steel, plain or ball bearings

For manual adjustments, large range of accessories available ▶ Page 613

Configurable with motor as a ready-to-install linear drive

## Lubrication-free linear modules - drylin® SHT

The drylin® SHT linear modules can be moved lubrication-free, while also offering high precision and robust components. The units can be individually configured with various shaft and lead screw materials, carriage lengths and additional functions. The SHT series is suitable for manual and motorised operation and is supplied ready for connection with drylin® motors.

- All bearing positions are completely lubrication-free due to the use of iglidur® high performance polymers
- Freely selectable stroke lengths
- High temperature version available
- SHT linear modules can be configured as a multi-carriage system or with right/left opposite drive

### Typical application areas

- Format adjustment
- Actuators
- Sensor adjustment
- Marking and engraving technology
- Laboratory equipment

 **Available in 3-8 days**  
Detailed information about delivery time online.

 **Price breaks online**  
No minimum order value. No minimum order quantity

 **Carriage lengths: 30-180mm**  
**Pitch: 2-100mm/rotation**  
**Stroke lengths: up to 1,500mm**

 **Product finder**  
▶ [www.igus.eu/sht-productfinder](http://www.igus.eu/sht-productfinder)

 **Configure SHT modules quickly and easily online**  
▶ [www.igus.eu/drylin-sht-configurator](http://www.igus.eu/drylin-sht-configurator)

100% lubrication and maintenance-free

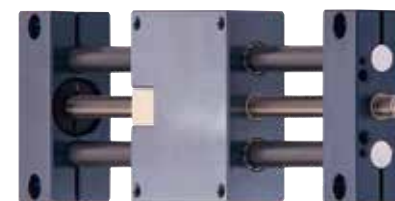

### SHT linear module - standard

- Solid design
  - Three different sizes
  - Various materials for shaft and lead screw
  - Maintenance-free and optionally corrosion-resistant
- ▶ Page 524

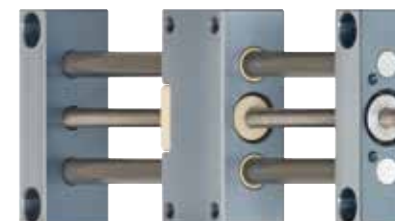

### SHTC linear module - variable

- Design flexibility due to short carriages
  - Ideal for 2 carriages
  - 5 sizes from Ø 12 up to 50mm
- ▶ Page 526

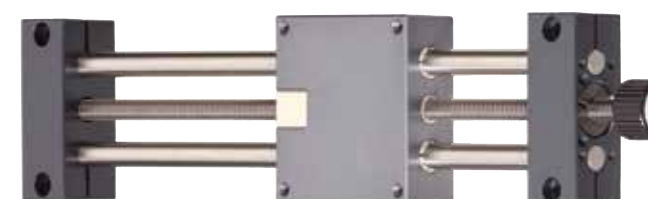

### SHT-BB linear module - ball-bearing supported

- Higher rotation speed and higher precision
  - Belt drive permits radial loads
  - Constant drive torque
  - Less axial clearance
- ▶ Page 528

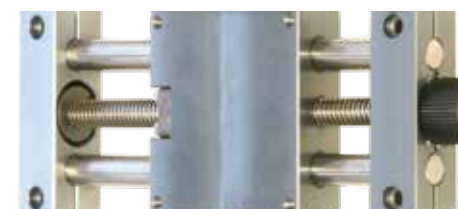

### SHT linear module made from stainless steel

- All components (shaft end supports, carriages, shafts, lead screws) made of corrosion-resistant stainless steel
  - Select bearings from three different iglidur® materials
- ▶ Page 530

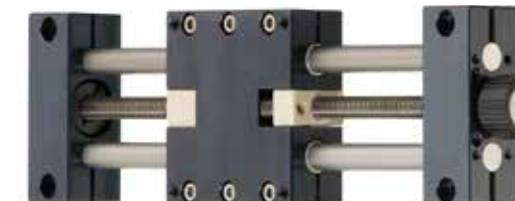

### SHT-PL linear modules, pre-load

- Pre-loaded trapezoidal lead screw nuts, pre-load force: 50N
  - Manually and continuously adjustable radial clearance
  - Lightweight due to aluminium and polymer
- ▶ Page 525



### SHTS linear module - the fast one

- With high helix lead screw
  - High-speed solution for fast positioning
  - Up to 100mm stroke/rotation
- ▶ Page 527

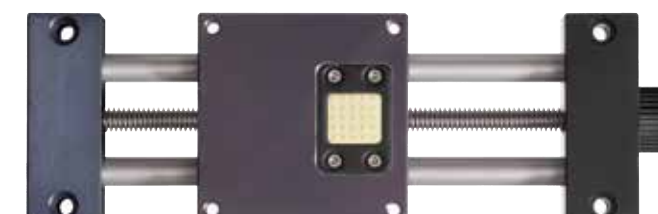

### SHT-FF linear module - "Fast-Forward"

- With quick-release mechanism
  - Precise and fast positioning
  - Including self-locking brake
  - Only recommended for horizontal applications
- ▶ Page 532

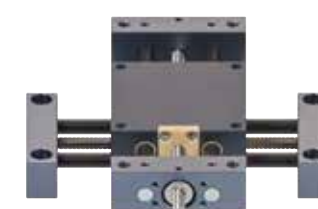

### XY-tables

- XY tables standard and pre-load
- ▶ Page 534

## Self-locking



- Solid design
- Various materials for shaft and lead screw
- Maintenance-free and optionally corrosion-resistant
- Tr6x2, Tr10x2, Tr18x4, Tr24x5
- Temperature-resistant up to +60°C
- Accessories available  
▶ **Page 613**
- Lead screw nuts are available separately ▶ **Page 470**
- **Available with motor**



Order example

## SHT-12-AWM

|          |                   |                |
|----------|-------------------|----------------|
| Standard | Installation size | Shaft material |
|----------|-------------------|----------------|



reddot design award  
winner 2006

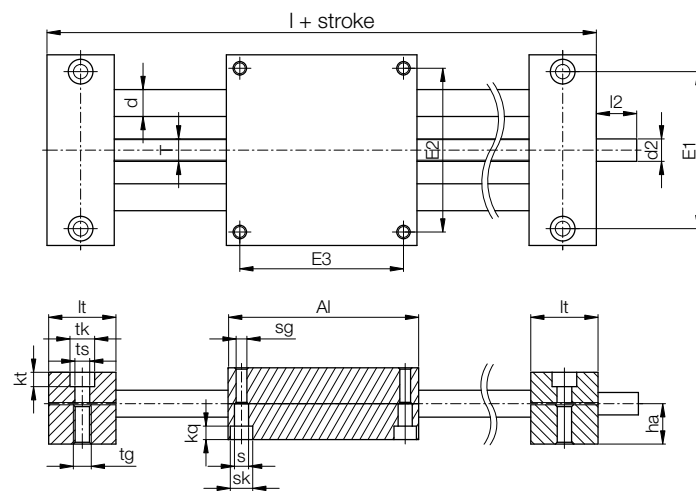
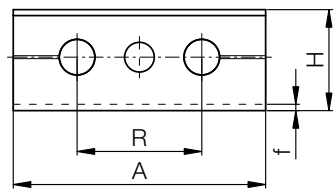

Configurable online  
▶ [www.igus.eu/drylin-SHT-configurator](http://www.igus.eu/drylin-SHT-configurator)

### Technical data

| Part No.   | Max. stroke length | Aluminium shaft |                    | Steel shaft |                    | Max. static load capacity |        |
|------------|--------------------|-----------------|--------------------|-------------|--------------------|---------------------------|--------|
|            |                    | Weight          | addit. (per 100mm) | Weight      | addit. (per 100mm) | axial                     | radial |
|            | [mm]               | [kg]            | [kg]               | [kg]        | [kg]               | [N]                       | [N]    |
| SHT-08-AWM | 300                | 0.24            | 0.05               | 0.27        | 0.1                | 100                       | 360    |
| SHT-12-AWM | 750                | 1.1             | 0.1                | 1.3         | 0.2                | 700                       | 2,800  |
| SHT-20-AWM | 1,000              | 3.2             | 0.3                | 3.9         | 0.6                | 1,600                     | 6,400  |
| SHT-30-AWM | 1,250              | 8.6             | 0.6                | 10.9        | 1.4                | 2,500                     | 10,000 |

### Dimensions [mm]

| Part No.   | A    | Al   | H  | E1    | E2    | E3    | I   | R  | f   | lt   | tk | ts   |
|------------|------|------|----|-------|-------|-------|-----|----|-----|------|----|------|
|            | -0.3 | -0.3 |    | ±0.15 | ±0.15 | ±0.15 |     |    |     |      |    |      |
| SHT-08-AWM | 65   | 65   | 23 | 52    | 55    | 55    | 96  | 32 | 1.5 | 15.5 | 10 | 5.5  |
| SHT-12-AWM | 85   | 85   | 34 | 70    | 73    | 73    | 145 | 42 | 2   | 30   | 11 | 6.6  |
| SHT-20-AWM | 130  | 130  | 48 | 108   | 115   | 115   | 202 | 72 | 2   | 36   | 15 | 9.0  |
| SHT-30-AWM | 180  | 180  | 68 | 150   | 158   | 158   | 280 | 96 | 4   | 50   | 20 | 13.5 |

| Part No.   | tg     | kt   | Øs   | sk | sg  | kq   | d  | T                      | l2 | d2                         | ha |
|------------|--------|------|------|----|-----|------|----|------------------------|----|----------------------------|----|
|            | ±0.1   | ±0.1 |      |    |     |      |    |                        |    | Standard                   |    |
| SHT-08-AWM | M6x8   | 7    | 4.2  | 8  | M5  | 4.6  | 8  | Tr6x2                  | 17 | Tr6x2                      | 13 |
| SHT-12-AWM | M8x18  | 6.4  | 5.3  | 10 | M6  | 6.0  | 12 | Tr10x2 <sup>157)</sup> | 17 | Tr10x2 <sup>92)</sup> 157) | 18 |
| SHT-20-AWM | M10x23 | 8.6  | 6.4  | 11 | M8  | 7.0  | 20 | Tr18x4                 | 26 | 12h9                       | 23 |
| SHT-30-AWM | M16x25 | 12.6 | 11.0 | 18 | M12 | 10.6 | 30 | Tr24x5                 | 38 | 14h9                       | 36 |

<sup>92)</sup> Lead screw end unmachined; <sup>157)</sup> Also available with Tr10x3

## Axial pre-load, radial adjustment

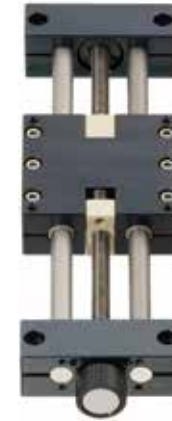

Pre-loaded trapezoidal lead screw nut



Order example

## SHT-12-AWM-PL

|          |                   |                |                            |
|----------|-------------------|----------------|----------------------------|
| Standard | Installation size | Shaft material | Clearance-free, pre-loaded |
|----------|-------------------|----------------|----------------------------|

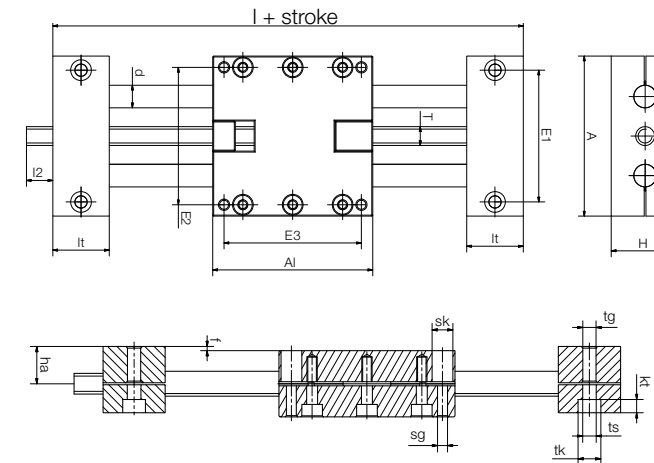

- Pre-loaded trapezoidal lead screw nuts, pre-load force: 50N
- Manually and continuously adjustable radial clearance
- Lightweight due to aluminium and polymer
- Lead screw end unmachined
- Temperature-resistant up to +60°C
- Accessories available ▶ **Page 613**
- Lead screw nuts are available separately ▶ **Page 470**
- **Available with motor**



Configurable online  
▶ [www.igus.eu/drylin-SHT-configurator](http://www.igus.eu/drylin-SHT-configurator)

### Technical data

| Part No.      | Max. stroke length | Aluminium shaft |                    | Steel shaft |                    | Max. static load capacity |        |
|---------------|--------------------|-----------------|--------------------|-------------|--------------------|---------------------------|--------|
|               |                    | Weight          | addit. (per 100mm) | Weight      | addit. (per 100mm) | axial                     | radial |
|               | [mm]               | [kg]            | [kg]               | [kg]        | [kg]               | [N]                       | [N]    |
| SHT-12-AWM-PL | 750                | 1.1             | 0.1                | 1.3         | 0.2                | 700                       | 2,800  |
| SHT-20-AWM-PL | 1,000              | 3.2             | 0.3                | 3.9         | 0.6                | 1,600                     | 6,400  |
| SHT-30-AWM-PL | 1,250              | 8.6             | 0.6                | 10.9        | 1.4                | 2,500                     | 10,000 |

### Dimensions [mm]

| Part No.      | A    | Al   | H  | E1    | E2    | E3    | I   | R  | f | lt | tk | ts   |
|---------------|------|------|----|-------|-------|-------|-----|----|---|----|----|------|
|               | -0.3 | -0.3 |    | ±0.15 | ±0.15 | ±0.15 |     |    |   |    |    |      |
| SHT-12-AWM-PL | 85   | 85   | 34 | 70    | 73    | 73    | 145 | 42 | 2 | 30 | 11 | 6.6  |
| SHT-20-AWM-PL | 130  | 130  | 48 | 108   | 115   | 115   | 202 | 72 | 2 | 36 | 15 | 9.0  |
| SHT-30-AWM-PL | 180  | 180  | 68 | 150   | 158   | 158   | 280 | 96 | 4 | 50 | 20 | 13.5 |

| Part No.      | tg     | kt   | sk | sg  | d  | T                      | l2 | d2                         | ha |
|---------------|--------|------|----|-----|----|------------------------|----|----------------------------|----|
|               |        | ±0.1 |    |     |    |                        |    | Standard                   |    |
| SHT-12-AWM-PL | M8x18  | 6.4  | 10 | M6  | 12 | Tr10x2 <sup>157)</sup> | 17 | Tr10x2 <sup>92)</sup> 157) | 18 |
| SHT-20-AWM-PL | M10x23 | 8.6  | 11 | M8  | 20 | Tr18x4                 | 26 | 12h9                       | 23 |
| SHT-30-AWM-PL | M16x25 | 12.6 | 18 | M12 | 30 | Tr24x5                 | 38 | 14h9                       | 36 |

<sup>92)</sup> Lead screw end unmachined; <sup>157)</sup> Also available with Tr10x3

## Compact design



- Design flexibility
- Ideal for 2 carriages
- Adjustable bearing clearance
- Accessories available
- ▶ **Page 613**
- Lead screw nuts are available separately ▶ **Page 470**
- Available with motor



### Order key



Order example

## SHTC-12-AWM

|          |                   |                |
|----------|-------------------|----------------|
| Flexible | Installation size | Shaft material |
|----------|-------------------|----------------|

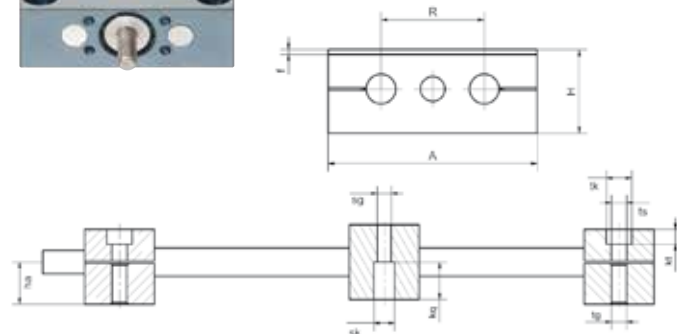

Configurable online

▶ [www.igus.eu/drylin-SHT-configurator](http://www.igus.eu/drylin-SHT-configurator)

### Technical data and dimensions [mm]

| Part No.     | Max. stroke length [mm] | Aluminium shaft |                         | Steel shaft |                         | Max. static load capacity |            |
|--------------|-------------------------|-----------------|-------------------------|-------------|-------------------------|---------------------------|------------|
|              |                         | Weight [kg]     | addit. (per 100mm) [kg] | Weight [kg] | addit. (per 100mm) [kg] | axial [N]                 | radial [N] |
| SHTC-08-AWM  | 300                     | 0.2             | 0.05                    | 0.23        | 0.1                     | 100                       | 360        |
| SHTC-12-AWM  | 750                     | 0.7             | 0.1                     | 0.8         | 0.2                     | 700                       | 2,800      |
| SHTC-20-AWM  | 1,000                   | 1.9             | 0.3                     | 2.3         | 0.6                     | 1,600                     | 6,400      |
| SHTC-30-AWM  | 1,250                   | 4.6             | 0.6                     | 5.8         | 1.4                     | 2,500                     | 10,000     |
| SHTC-40-SWMH | 1,500                   | 11.0            | 0.9                     | 16.0        | 2.4                     | 4,000                     | 16,000     |
| SHTC-50-SWMH | 1,500                   | 17.0            | 1.2                     | 26.3        | 3.5                     | 6,250                     | 25,000     |

| Part No.     | A   | Al | H   | E1  | E2  | I   | R   | f   | lt   | tk | ts   | tg     |
|--------------|-----|----|-----|-----|-----|-----|-----|-----|------|----|------|--------|
|              |     |    |     |     |     |     |     |     |      |    |      |        |
| SHTC-08-AWM  | 65  | 38 | 23  | 55  | 55  | 69  | 32  | 1.5 | 15.5 | 10 | 5.5  | M6x8   |
| SHTC-12-AWM  | 85  | 30 | 34  | 70  | 73  | 90  | 42  | 2   | 30   | 11 | 6.6  | M8x18  |
| SHTC-20-AWM  | 130 | 36 | 48  | 108 | 115 | 108 | 72  | 2   | 36   | 15 | 9.0  | M10x23 |
| SHTC-30-AWM  | 180 | 50 | 68  | 150 | 158 | 150 | 96  | 4   | 50   | 20 | 13.5 | M16x25 |
| SHTC-40-SWMH | 230 | 70 | 84  | 202 | 202 | 210 | 122 | 4   | 70   | 20 | 13.5 | M16x40 |
| SHTC-50-SWMH | 280 | 80 | 100 | 250 | 250 | 240 | 152 | 4   | 80   | 20 | 13.5 | M16x35 |

| Part No.     | kt ±0.1 | sk | sg  | kq   | d  | T                      | l2 | d2                         | ha |
|--------------|---------|----|-----|------|----|------------------------|----|----------------------------|----|
|              |         |    |     |      |    |                        |    |                            |    |
| SHTC-08-AWM  | 7       | 8  | M5  | 4.6  | 8  | Tr6x2                  | 17 | Tr6x2                      | 13 |
| SHTC-12-AWM  | 6.4     | 10 | M6  | 6.0  | 12 | Tr10x2 <sup>157)</sup> | 17 | Tr10x2 <sup>92) 157)</sup> | 18 |
| SHTC-20-AWM  | 8.6     | 11 | M8  | 7.0  | 20 | Tr18x4                 | 26 | 12h9                       | 23 |
| SHTC-30-AWM  | 12.6    | 18 | M12 | 10.6 | 30 | Tr24x5                 | 38 | 14h9                       | 36 |
| SHTC-40-SWMH | 12.6    | 20 | M16 | 39   | 40 | Tr26x5                 | 45 | 16h9                       | 44 |
| SHTC-50-SWMH | 12.6    | 20 | M16 | 49   | 50 | Tr30x6                 | 50 | 20h9                       | 52 |

<sup>92)</sup> Lead screw end unmachined; <sup>157)</sup> Also available with Tr10x3

## The fast one with dryspin® high helix thread



- Pitch Ds10x12, Ds10x50, Ds18x100
- High-speed solution
- Accessories available
- ▶ **Page 613**
- Lead screw nuts are available separately ▶ **Page 470**
- Available with motor



### Order key



Order example

## SHT S-12-AWM-10x12

|          |                   |           |                |       |
|----------|-------------------|-----------|----------------|-------|
| Standard | High helix thread | Dimension | Shaft material | Pitch |
|----------|-------------------|-----------|----------------|-------|



reddot design award  
winner 2006



Configurable online

▶ [www.igus.eu/drylin-SHT-configurator](http://www.igus.eu/drylin-SHT-configurator)



The complete overview of the available lead screw sizes can be found on ▶ **Page 510**

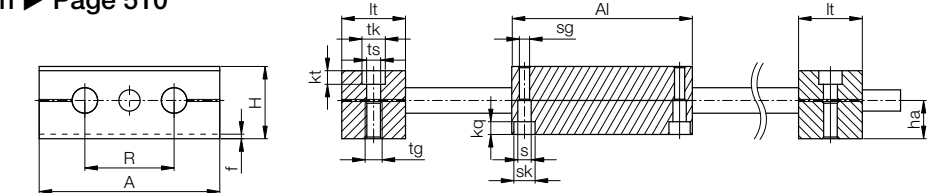
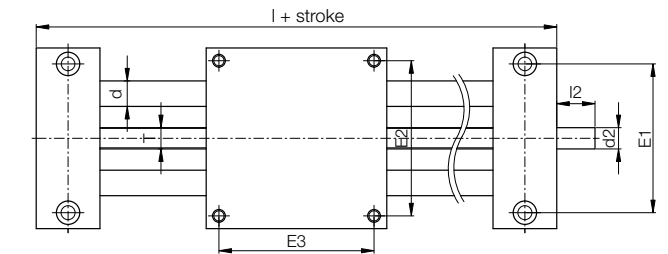

### Technical data and dimensions [mm]

| Part No.                    | Max. stroke length [mm] | Aluminium shaft |                             | Max. static load capacity |            |
|-----------------------------|-------------------------|-----------------|-----------------------------|---------------------------|------------|
|                             |                         | Weight [kg]     | additional (per 100mm) [kg] | axial [N]                 | radial [N] |
| SHTS-12-AWM-10x12           | 750                     | 1.1             | 0.1                         | 100                       | 400        |
| SHTS-12-AWM-10x50           | 750                     | 1.1             | 0.1                         | 100                       | 400        |
| SHTS-20-AWM-18x100          | 1,000                   | 3.2             | 0.3                         | 400                       | 1,600      |
| SHTS-30-AWM-20x5 <b>New</b> | 1,000                   | 8.6             | 0.6                         | 1,000                     | 4,000      |

### Dimensions [mm]

| Part No.                    | A   | Al  | H  | E1  | E2  | E3  | I   | R  | f | lt | tk | ts   | tg     |
|-----------------------------|-----|-----|----|-----|-----|-----|-----|----|---|----|----|------|--------|
|                             |     |     |    |     |     |     |     |    |   |    |    |      |        |
| SHTS-12-AWM-10x12           | 85  | 85  | 34 | 70  | 73  | 73  | 145 | 42 | 2 | 30 | 11 | 6.6  | M6x8   |
| SHTS-12-AWM-10x50           | 85  | 85  | 34 | 70  | 73  | 73  | 145 | 42 | 2 | 30 | 11 | 6.6  | M6x8   |
| SHTS-20-AWM-18x100          | 130 | 130 | 48 | 108 | 115 | 115 | 202 | 72 | 2 | 36 | 15 | 9.0  | M10x23 |
| SHTS-30-AWM-20x5 <b>New</b> | 180 | 180 | 68 | 150 | 158 | 158 | 280 | 96 | 4 | 50 | 20 | 13.5 | M16x25 |

| Part No.                    | kt ±0.1 | Øs  | sk | sg  | kq   | d  | T      | l2 | d2                     | ha |
|-----------------------------|---------|-----|----|-----|------|----|--------|----|------------------------|----|
|                             |         |     |    |     |      |    |        |    |                        |    |
| SHTS-12-AWM-10x12           | 6.4     | 6.3 | 10 | M6  | 6.0  | 12 | 10x12  | 17 | Ds10x12 <sup>92)</sup> | 18 |
| SHTS-12-AWM-10x50           | 6.4     | 6.3 | 10 | M6  | 6.0  | 12 | 10x50  | 17 | Ds10x50 <sup>92)</sup> | 18 |
| SHTS-20-AWM-18x100          | 8.6     | 6.4 | 11 | M8  | 7.0  | 20 | 18x100 | 26 | 12h9                   | 23 |
| SHTS-30-AWM-20x5 <b>New</b> | 12.6    | 11  | 18 | M12 | 10.6 | 30 | Ds20x5 | 38 | 14h9                   | 36 |

<sup>92)</sup> Lead screw end unmachined



With ball bearing supported lead screw



- Higher speeds
- Higher precision
- Reduced axial clearance
- Belt drive permits radial loads
- Constant drive torque
- Zero-backlash function available for sizes 08 and 12
- Accessories available  
▶ **Page 613**
- Lead screw nuts are available separately ▶ **Page 470**
- Available with motor



Order key



Order example

**SHT-BB-12-AWM**

|          |              |                   |                |
|----------|--------------|-------------------|----------------|
| Standard | Ball bearing | Installation size | Shaft material |
|----------|--------------|-------------------|----------------|



Order key

Order example

**SHT-08-ZB-AWM**

|          |                   |                             |                |
|----------|-------------------|-----------------------------|----------------|
| Standard | Installation size | Ball bearing, zero-backlash | Shaft material |
|----------|-------------------|-----------------------------|----------------|



Configurable online

▶ [www.igus.eu/drylin-SHT-configurator](http://www.igus.eu/drylin-SHT-configurator)

## Technical data

| Part No.                | Max. stroke length<br>[mm] | Aluminium shaft |                               | Steel shaft    |                               | Max. static load capacity |               |
|-------------------------|----------------------------|-----------------|-------------------------------|----------------|-------------------------------|---------------------------|---------------|
|                         |                            | Weight<br>[kg]  | addit.<br>(per 100mm)<br>[kg] | Weight<br>[kg] | addit.<br>(per 100mm)<br>[kg] | axial<br>[N]              | radial<br>[N] |
|                         |                            |                 |                               |                |                               |                           |               |
| SHTC-08-ZB-AWM          | 300                        | 0.240           | 0.05                          | 0.270          | 0.094                         | 100                       | 360           |
| SHT-08-ZB-AWM-6X2P1     | 300                        | 0.205           | 0.05                          | 0.228          | 0.103                         | 100                       | 400           |
| SHT-08-ZB-AWM-6.35x12.7 | 300                        | 0.205           | 0.05                          | 0.228          | 0.103                         | 100                       | 400           |
| SHT-12-ZB-AWM-10x12     | 500                        | 1.1             | 0.1                           | 1.3            | 0.2                           | 150                       | 600           |
| SHT-BB-12-AWM           | 500                        | 1.1             | 0.1                           | 1.3            | 0.2                           | 350                       | 1,400         |
| SHT-BB-20-AWM           | 900                        | 3.2             | 0.3                           | 3.9            | 0.6                           | 1,000                     | 4,000         |
| SHT-BB-30-AWM           | 1,000                      | 8.6             | 0.6                           | 10.9           | 1.4                           | 1,500                     | 6,000         |

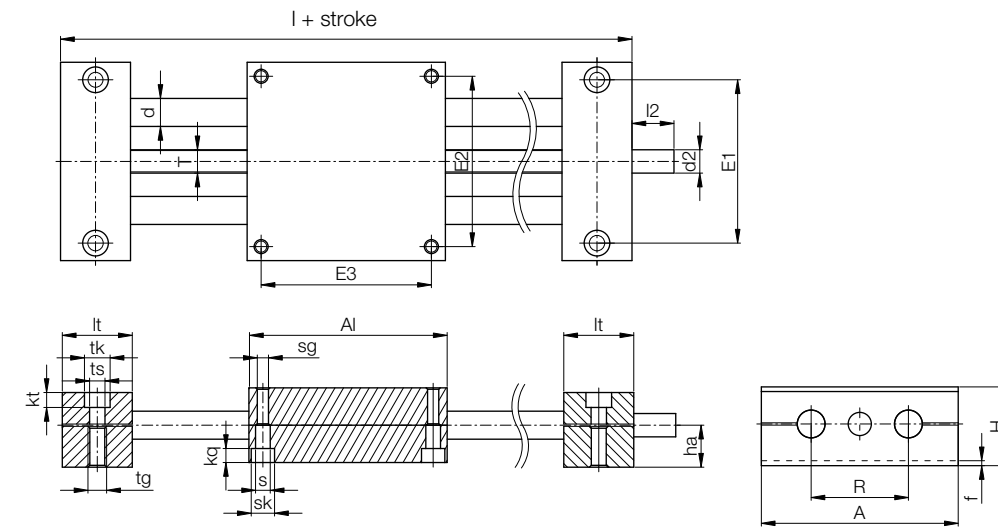

## Dimensions [mm]

| Part No.                | A    | AI   | H  | E1    | E2    | E3    | I   | R  | f   | lt   | tk | ts   |
|-------------------------|------|------|----|-------|-------|-------|-----|----|-----|------|----|------|
|                         | -0.3 | -0.3 |    | ±0.15 | ±0.15 | ±0.15 |     |    |     |      |    |      |
| SHTC-08-ZB-AWM          | 65   | 38   | 23 | 52    | 55    | 26    | 96  | 32 | 1.5 | 15.5 | 10 | 5.5  |
| SHT-08-ZB-AWM-6X2P1     | 65   | 65   | 23 | 52    | 55    | 55    | 96  | 32 | 1.5 | 15.5 | 10 | 5.5  |
| SHT-08-ZB-AWM-6.35x12.7 | 65   | 65   | 23 | 52    | 55    | 55    | 96  | 32 | 1.5 | 15.5 | 10 | 5.5  |
| SHT-12-ZB-AWM-10x12     | 85   | 85   | 34 | 70    | 73    | 73    | 145 | 42 | 2   | 30   | 11 | 6.6  |
| SHT-BB-12-AWM           | 85   | 85   | 34 | 70    | 73    | 73    | 145 | 42 | 2   | 30   | 11 | 6.6  |
| SHT-BB-20-AWM           | 130  | 130  | 48 | 108   | 115   | 115   | 202 | 72 | 2   | 36   | 15 | 9.0  |
| SHT-BB-30-AWM           | 180  | 180  | 68 | 150   | 158   | 158   | 280 | 96 | 4   | 50   | 20 | 13.5 |

| Part No.                | tg     | kt   | Øs   | sk | sg  | kq   | d  | T         | l2 | d2                    | ha |
|-------------------------|--------|------|------|----|-----|------|----|-----------|----|-----------------------|----|
|                         |        | ±0.1 |      |    |     |      |    |           |    | Standard              |    |
| SHTC-08-ZB-AWM          | M6x8   | 7    | 4.2  | 8  | M5  | 4.6  | 8  | 6 / 6.35  | 15 | 6 / 6.35              | 13 |
| SHT-08-ZB-AWM-6X2P1     | M6x8   | 7    | 4.2  | 8  | M5  | 4.6  | 8  | Tr6x2     | 15 | Tr6x2 <sup>92)</sup>  | 13 |
| SHT-08-ZB-AWM-6.35x12.7 | M6x8   | 7    | 4.2  | 8  | M5  | 4.6  | 8  | 6.35x12.7 | 15 | 6.35 <sup>92)</sup>   | 13 |
| SHT-12-ZB-AWM-10x12     | M8x18  | 6.4  | 6.3  | 10 | M6  | 6.0  | 12 | 10x12     | 17 | 10x12 <sup>92)</sup>  | 18 |
| SHT-BB-12-AWM           | M8x18  | 6.4  | 6.3  | 10 | M6  | 6.0  | 12 | Tr10x2    | 17 | Tr10x2 <sup>92)</sup> | 18 |
| SHT-BB-20-AWM           | M10x23 | 8.6  | 6.4  | 11 | M8  | 7.0  | 20 | Tr18x4    | 26 | 12h9                  | 23 |
| SHT-BB-30-AWM           | M16x25 | 12.6 | 11.0 | 18 | M12 | 10.6 | 30 | Tr24x5    | 38 | 14h9                  | 36 |

<sup>92)</sup> Lead screw end unmachined

Made of stainless steel



- Corrosion-resistant carriages and shaft end supports made of stainless steel
- High grade stainless steel shafts (AISI 440B)
- Choice of bearing material:  
iglidur® J = Standard  
iglidur® A180 = FDA-compliant  
iglidur® X = High temperature up to +150°C<sup>117)</sup>
- Can be configured online as SHTC compact version

Order key



Order example

**SHT-ES J - 08**

|          |                 |                  |                   |
|----------|-----------------|------------------|-------------------|
| Standard | Stainless steel | Bearing material | Installation size |
|----------|-----------------|------------------|-------------------|

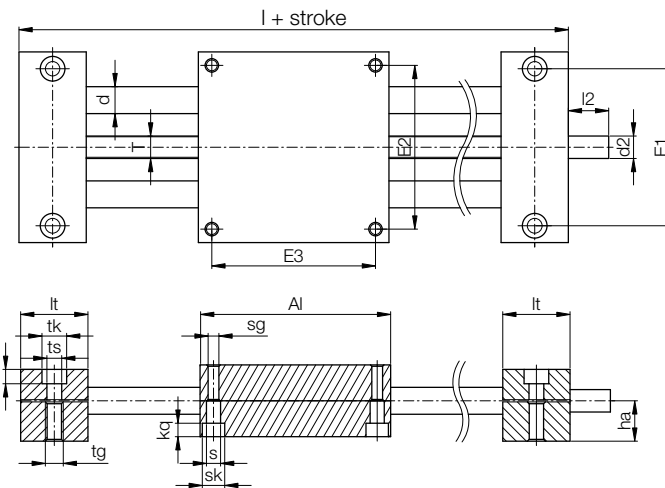

Configurable online  
▶ [www.igus.eu/drylin-SHT-configurator](http://www.igus.eu/drylin-SHT-configurator)



### Technical data

| Part No.   | Max. stroke length [mm] | Steel shaft |                             |           | Max. static load capacity |  |
|------------|-------------------------|-------------|-----------------------------|-----------|---------------------------|--|
|            |                         | Weight [kg] | additional (per 100mm) [kg] | axial [N] | radial [N]                |  |
| SHT-ESJ-08 | 300                     | 1.01        | 0.1                         | 100       | 360                       |  |
| SHT-ESJ-12 | 750                     | 2.81        | 0.24                        | 700       | 2,800                     |  |
| SHT-ESJ-20 | 1,000                   | 8.72        | 0.7                         | 1,600     | 6,400                     |  |
| SHT-ESJ-30 | 1,250                   | 24.11       | 1.47                        | 2,500     | 10,000                    |  |

### Dimensions [mm]

| Part No.   | A    | Al   | H  | E1    | E2    | E3    | I   | R  | f   | It   | tk | ts   |
|------------|------|------|----|-------|-------|-------|-----|----|-----|------|----|------|
|            | -0.3 | -0.3 |    | ±0.15 | ±0.15 | ±0.15 |     |    |     |      |    |      |
| SHT-ESJ-08 | 65   | 65   | 23 | 52    | 55    | 55    | 96  | 32 | 1.5 | 15.5 | 10 | 5.5  |
| SHT-ESJ-12 | 85   | 85   | 34 | 70    | 73    | 73    | 145 | 42 | 2   | 30   | 11 | 6.6  |
| SHT-ESJ-20 | 130  | 130  | 48 | 108   | 115   | 115   | 202 | 72 | 2   | 36   | 15 | 9.0  |
| SHT-ESJ-30 | 180  | 180  | 68 | 150   | 158   | 158   | 280 | 96 | 4   | 50   | 20 | 13.5 |

| Part No.   | tg     | kt   | Øs   | sk | sg  | kq   | d  | T      | l2 | d2                    | ha |
|------------|--------|------|------|----|-----|------|----|--------|----|-----------------------|----|
|            |        | ±0.1 |      |    |     |      |    |        |    | Standard              |    |
| SHT-ESJ-08 | M6x8   | 7    | 4.2  | 8  | M5  | 4.6  | 8  | Tr6x2  | 17 | Tr6x2                 | 13 |
| SHT-ESJ-12 | M8x18  | 6.4  | 6.3  | 10 | M6  | 6.0  | 12 | Tr10x2 | 17 | Tr10x2 <sup>92)</sup> | 18 |
| SHT-ESJ-20 | M10x23 | 8.6  | 6.4  | 11 | M8  | 7.0  | 20 | Tr18x4 | 26 | 12h9                  | 23 |
| SHT-ESJ-30 | M16x25 | 12.6 | 11.0 | 18 | M12 | 10.6 | 30 | Tr24x5 | 38 | 14h9                  | 36 |

<sup>92)</sup> Lead screw end unmachined

<sup>117)</sup> In the event of severe temperature fluctuations during transport, storage and use, thermal expansion effects cannot be ruled out

Hygienic design



Order key



Order example

**SHTC-20-EWM- HYD**

|          |           |                |                 |
|----------|-----------|----------------|-----------------|
| Flexible | Dimension | Shaft material | Hygienic design |
|----------|-----------|----------------|-----------------|

- Lightweight
- For washdown
- Wide gaps
- Materials: plastic and stainless steel
- Lead screw nuts made of FDA-compliant iglidur® A180
- Accessories available ▶ **Page 613**

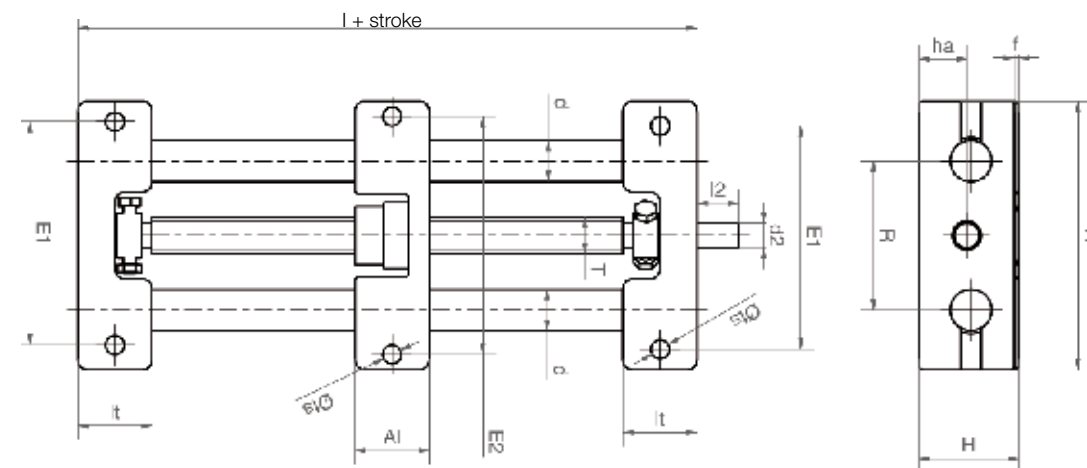

**FDA** The lead screw linear unit can be delivered with complete FDA-compliant materials.

### Dimensions [mm]

| Part No.        | A    | Al   | H  | E1    | E2    | I   | R  | f | It | ts  | d  | T      | l2 | d2    | ha |
|-----------------|------|------|----|-------|-------|-----|----|---|----|-----|----|--------|----|-------|----|
|                 | -0.3 | -0.3 |    | ±0.15 | ±0.15 |     |    |   |    |     |    |        |    |       |    |
| SHTC-20-EWM-HYD | 130  | 35   | 48 | 108   | 115   | 108 | 72 | 2 | 36 | 9.0 | 20 | Tr18x4 | 26 | 12 h9 | 23 |

With "Fast-Forward" quick release mechanism

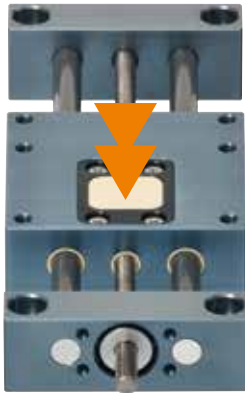

- Fast manual format adjustments
- Precise aluminium version
- Variable stroke length
- Multi-carriage solutions
- Recommended only for horizontal applications
- Accessories available ► Page 613
- Available with motor

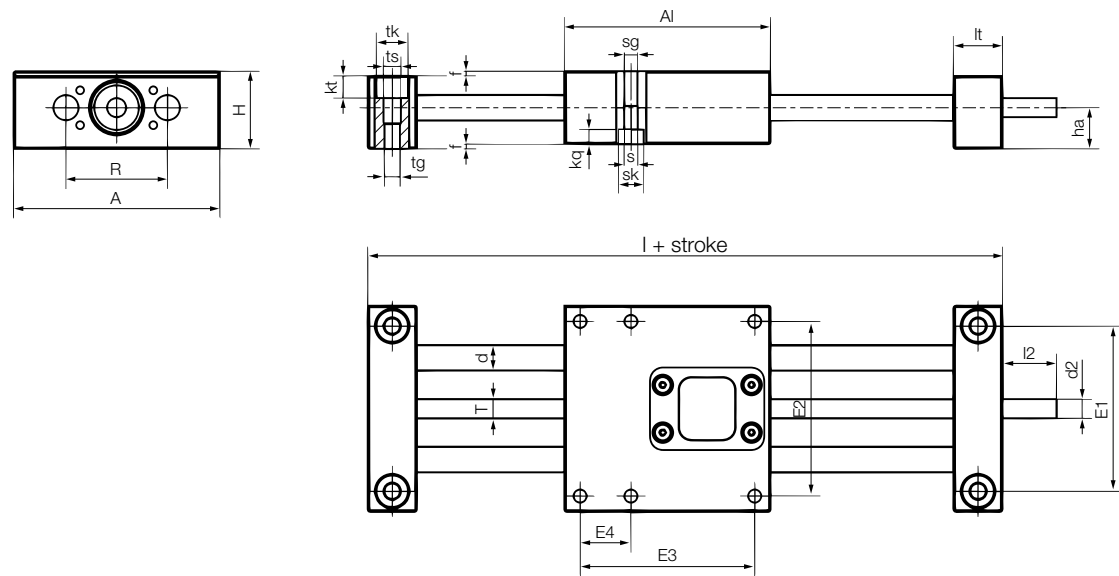

## Technical data

| Part No.      | Max. stroke length | Aluminium shaft |                    | Max. static axial load |
|---------------|--------------------|-----------------|--------------------|------------------------|
|               |                    | Weight          | addit. (per 100mm) |                        |
|               | [mm]               | [kg]            | [kg]               | [N]                    |
| SHT-08-AWM-FF | 300                | 0.35            | 0.04               | 100                    |
| SHT-12-AWM-FF | 750                | 1.1             | 0.1                | 150                    |

## Dimensions [mm]

| Part No.      | A  | Al | H  | E1 | E2 | E3 | E4 | I   | R  | It   | I2 | d2                    |
|---------------|----|----|----|----|----|----|----|-----|----|------|----|-----------------------|
| SHT-08-AWM-FF | 65 | 65 | 23 | 52 | 55 | 55 | 16 | 96  | 32 | 15.5 | 17 | 6                     |
| SHT-12-AWM-FF | 85 | 85 | 34 | 70 | 73 | 73 |    | 145 | 42 | 30   | 17 | Tr10x2 <sup>92)</sup> |

| Part No.      | f   | tk   | ts  | tg    | kt  | Øs  | sk | sg | kg  | d        | T      | ha |
|---------------|-----|------|-----|-------|-----|-----|----|----|-----|----------|--------|----|
|               |     | ±0.1 |     |       |     |     |    |    |     | Standard |        |    |
| SHT-08-AWM-FF | 1.5 | 10   | 5.5 | M6x8  | 7   | 4.2 | 8  | M5 | 4.6 | 8        | 6      | 13 |
| SHT-12-AWM-FF | 2   | 11   | 6.6 | M8x18 | 6.4 | 6.3 | 10 | M6 | 6.0 | 12       | Tr10x2 | 18 |

<sup>92)</sup> Lead screw end unmachined

With "Fast-Forward" quick release mechanism



- Fast manual format adjustments
- Aluminium version
- For fast format adjustments
- Including self-locking brake
- Variable stroke length
- Only recommended for horizontal applications
- Max. stat. axial load 200N (horizontal mounting position)
- Max. dynamic. axial load 50N
- Accessories available
- Page 613
- Available with motor

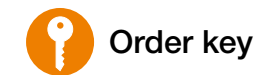

Order example

**SHT-12-AWM-FF**

|          |                   |                |              |
|----------|-------------------|----------------|--------------|
| Standard | Installation size | Shaft material | Fast Forward |
|----------|-------------------|----------------|--------------|

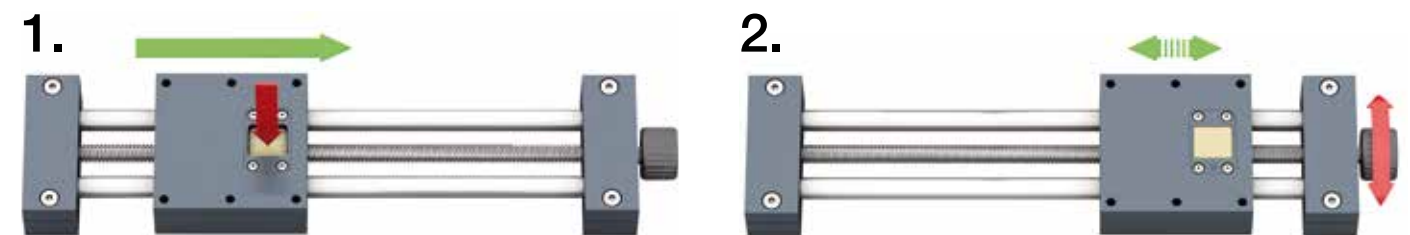
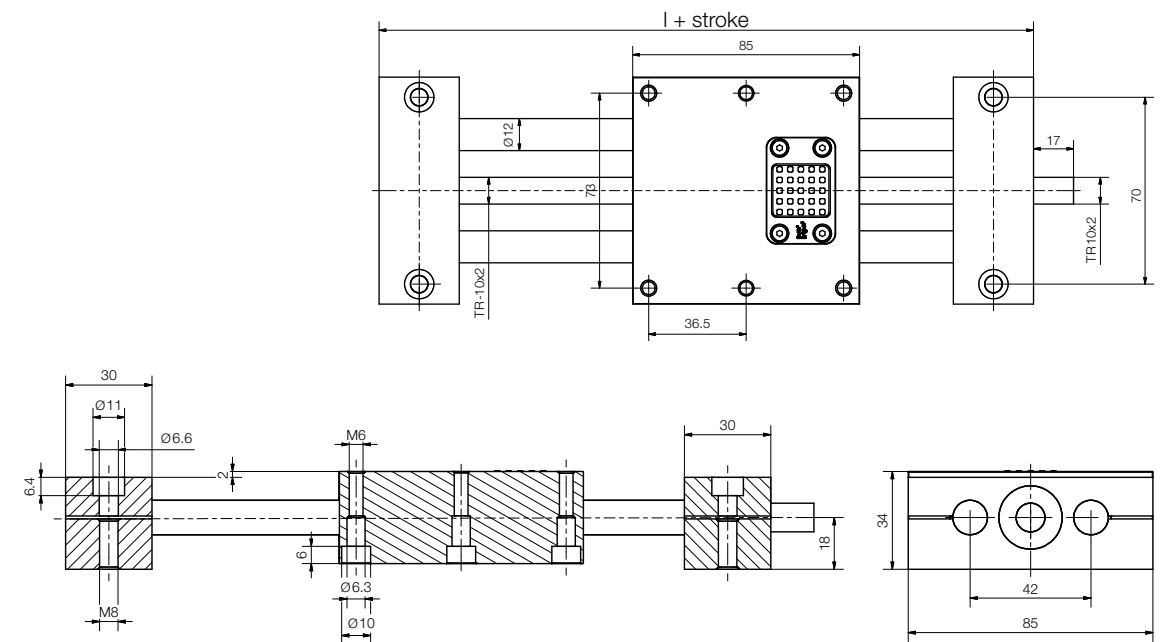

press > disengage > move manually > click into place > fine-tuning



Order key

Order example

**SHT-XY-12-AWM-PL-R**

|          |          |           |                |                     |      |
|----------|----------|-----------|----------------|---------------------|------|
| Standard | XY table | Dimension | Shaft material | Pre-load (optional) | Unit |
|----------|----------|-----------|----------------|---------------------|------|

Options: unit

R: y-unit

right adjustment

L: y-unit

left adjustment

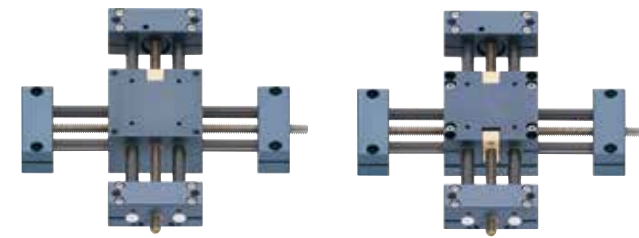
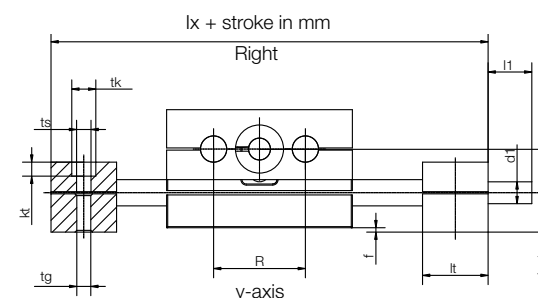
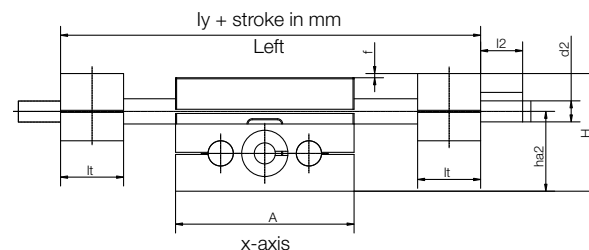

drylin® SHT

drylin® SHT-PL

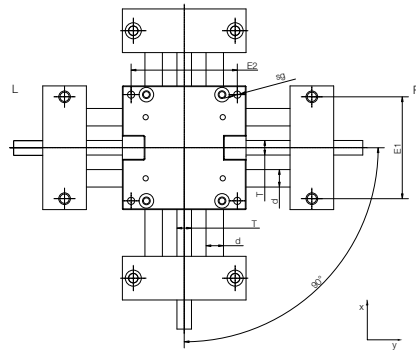

- Available as standard and pre-loaded version
- High precision, extreme stiffness and accurate alignment due to the single-piece carriage
- Adjustments by trapezoidal thread
- Assembly of upper unit with left or right alignment possible
- Accessories available ► **Page 613**

Select versions and accessories online  
► [www.igus.eu/drylinSHT](http://www.igus.eu/drylinSHT)

### Dimensions [mm]

| Part No.                        | Max. stroke length [mm] | A   | H  | E1  | E2  | Base length lx | Base length ly | R  | f   | lt   | tk | ts  | tg     | kt  |
|---------------------------------|-------------------------|-----|----|-----|-----|----------------|----------------|----|-----|------|----|-----|--------|-----|
| SHT-XY-08-AWM                   | 150                     | 65  | 42 | 52  | 56  | 96             | 96             | 32 | 1.5 | 15.5 | 10 | 5.5 | M6x8   | 7   |
| SHT-XY-12-AWM                   | 350                     | 85  | 56 | 70  | 73  | 145            | 145            | 42 | 2   | 30   | 11 | 6.6 | M8x18  | 6.4 |
| SHT-XY-12-AWM-PL                | 350                     | 85  | 56 | 70  | 73  | 145            | 145            | 42 | 2   | 30   | 11 | 6.6 | M8x18  | 6.4 |
| SHT-XY-20-EWM-PL <sup>93)</sup> | 500                     | 130 | 86 | 108 | 115 | 202            | 202            | 72 | 2   | 36   | 15 | 9.0 | M10x23 | 8.6 |

| Part No.                        | sg | d  | T                     | l1 | d1                    |             | l2 | d2       |             | ha1 | ha2 | W  |
|---------------------------------|----|----|-----------------------|----|-----------------------|-------------|----|----------|-------------|-----|-----|----|
|                                 |    |    |                       |    | Standard              | Alternative |    | Standard | Alternative |     |     |    |
| SHT-XY-08-AWM                   | M5 | 8  | Tr6x2/<br>Tr6.35x2.54 | 15 | Tr6x2/<br>Tr6.35x2.54 | -           | 15 | 5        | -           | 13  | 29  | 16 |
| SHT-XY-12-AWM                   | M6 | 12 | Tr10x2                | 17 | Tr10x2                | 6 h9        | 17 | Tr10x2   | 6 h9        | 18  | 38  | 20 |
| SHT-XY-12-AWM-PL                | M6 | 12 | Tr10x2                | 17 | Tr10x2                | 6 h9        | 17 | Tr10x2   | 6 h9        | 18  | 38  | 20 |
| SHT-XY-20-EWM-PL <sup>93)</sup> | M8 | 20 | TR18x4                | 26 | TR18x4                | 12 h9       | 26 | 12 h9    | -           | 23  | 63  | 40 |

Required accessories (e.g. hand wheel) can be ordered left- or right-mounted in the y-direction.

Order example for SHT-XY-12-AWM-L-200-300-HR, left adjustment, stroke 200/300mm, two hand wheels

<sup>93)</sup> For size 20 we recommend stainless steel shafts (EWM), AWM also available

## drylin® general drive technology - SLW linear modules

Lubrication-free linear modules based on drylin® W guides

Drive: Trapezoidal or high helix lead screw

Torsion-resistant double shaft systems

Many carriage and rail options

Suitable for manual and motor-operated adjustments

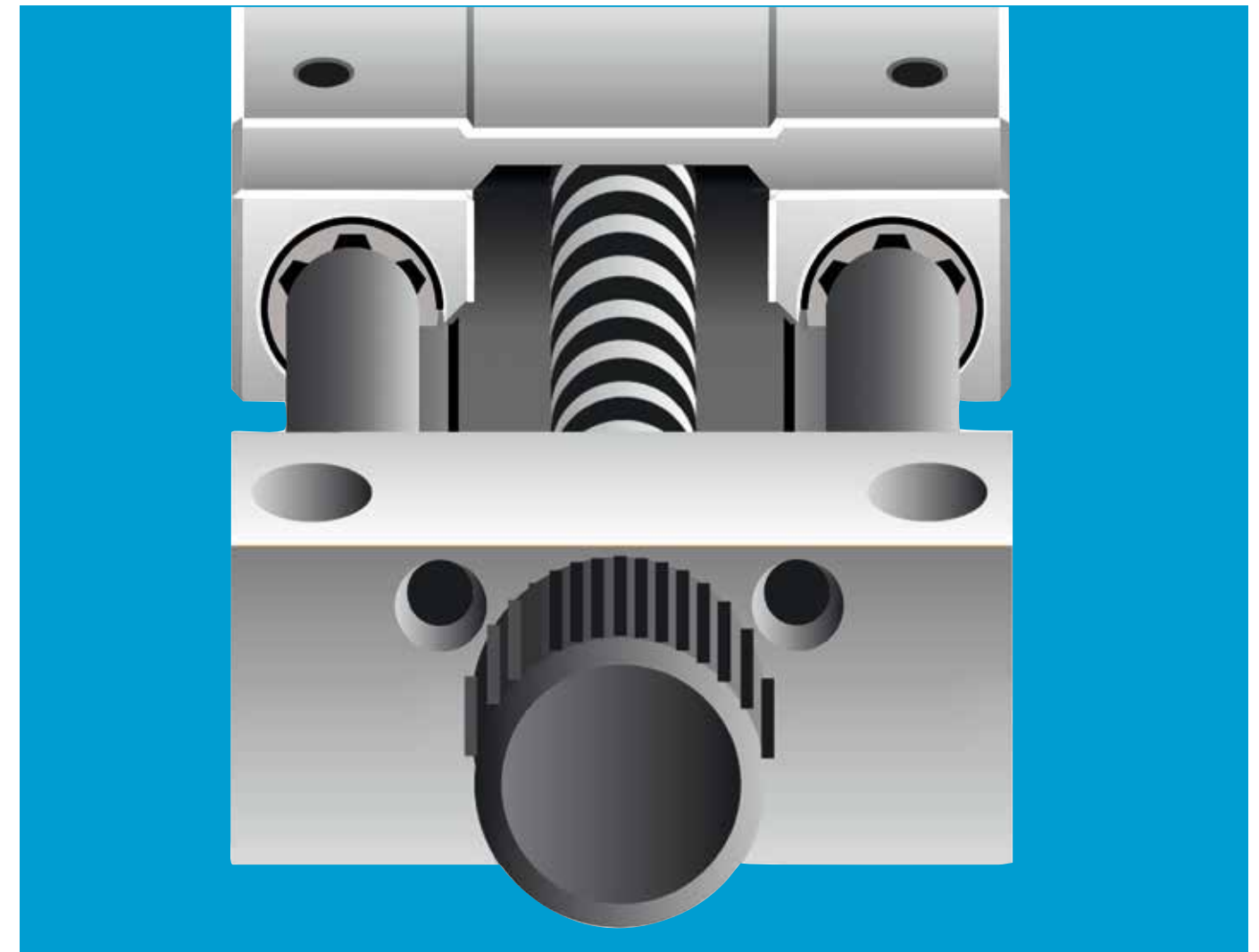



Modular design

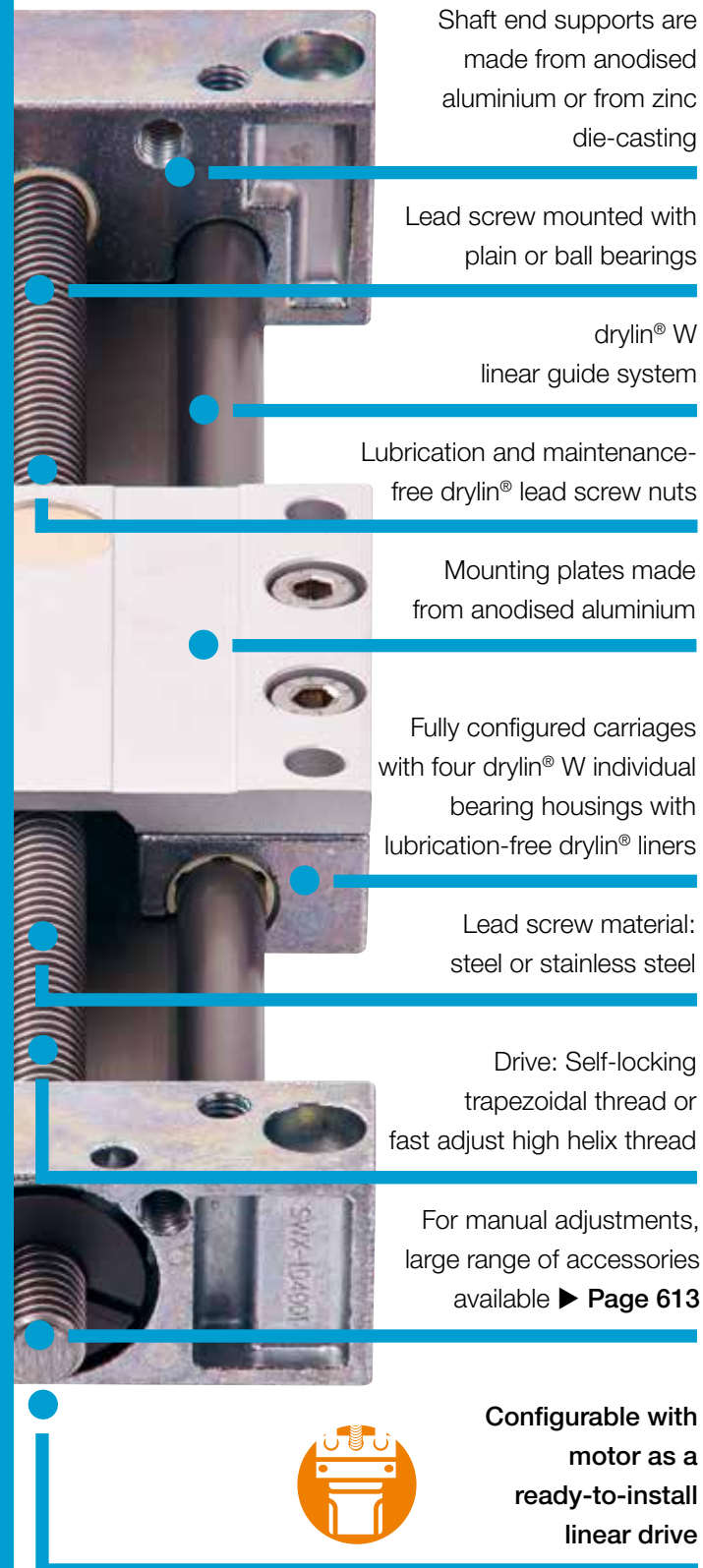

Shaft end supports are made from anodised aluminium or from zinc die-casting

Lead screw mounted with plain or ball bearings

drylin® W linear guide system

Lubrication and maintenance-free drylin® lead screw nuts

Mounting plates made from anodised aluminium

Fully configured carriages with four drylin® W individual bearing housings with lubrication-free drylin® liners

Lead screw material: steel or stainless steel

Drive: Self-locking trapezoidal thread or fast adjust high helix thread

For manual adjustments, large range of accessories available ▶ Page 613

Configurable with motor as a ready-to-install linear drive



## Lubrication-free linear modules - drylin® SLW

Torsion-resistant aluminium double shaft rails with many carriage versions characterise the drylin® W product range, and form a well rounded modular kit for the drylin® SLW linear modules. The modules are low profile, as well as robust. The drylin® SLW linear modules are ideal for manual adjustments, but can also be fitted with a motor to make an electrical linear actuator.

- Variable carriage widths and lengths
- Flat drylin® guide rails or high profile
- Corrosion-resistant option made of stainless steel available

### Typical application areas

- Format and lane adjustments
- Packaging technology
- Height adjustments
- 3D printer
- Camera adjustment

**Available in 3-8 days**  
Detailed information about delivery time online.

**Price breaks online**  
No minimum order value. No minimum order quantity

**Carriage lengths: 60-250mm**  
**Carriage widths: 54-195mm**  
**Stroke lengths: up to 1,250mm**

**Product finder**  
▶ [www.igus.eu/slw-productfinder](http://www.igus.eu/slw-productfinder)

Flat and torsion-resistant



### SLW linear module - compact

- High torsional stability, fully supported
- Cost-effective
- Shaft end supports made from zinc, anodised aluminium or plastic (depending on installation size)

▶ Page 538



### SLWE-BB linear module, ball bearing

- Efficient and dynamic
- Quiet, reduced clearance
- Up to 1,500rpm (depending on length and load)

▶ Page 543

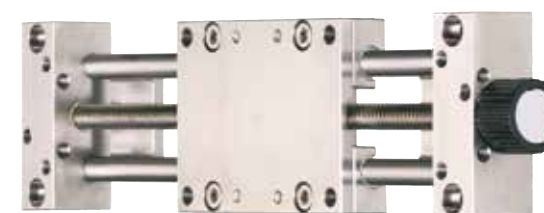

### SLW-ES linear module - stainless steel version

- With corrosion-resistant steel components
- Choice of bearing material: iglidur® J (standard), iglidur® A180 (FDA-compliant), iglidur® X (high temperature up to +150°C)
- For environments involving contact with water and chemicals

▶ Page 548



### SLWE-PL linear module, pre-load

- Lubrication-free and precise
- Pre-loaded trapezoidal lead screw nut (pre-load force: 50N)
- Manually adjustable radial clearance, reduction of the axial clearance

▶ Page 541

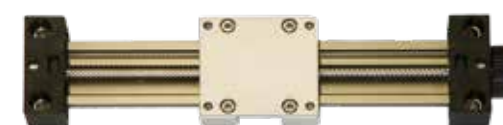

### SLWS linear module with dryspin® high helix technology

- Fast positioning
- High-helix lead screw drives
- Up to 100mm stroke per rotation

▶ Page 544



### Linear module special designs

- SLW with protect mechanism for applications with high levels of dirt
- High flexibility through SLWT with double lead screw
- XY table solutions

▶ Page 551

## Self-locking



- Flat and compact
- High torsional stability
- Fully supported
- Aluminium drylin® W guide rails, hard-anodised
- Accessories available  
▶ **Page 613**
- Lead screw nuts are available separately ▶ **Page 472**
- Available with motor

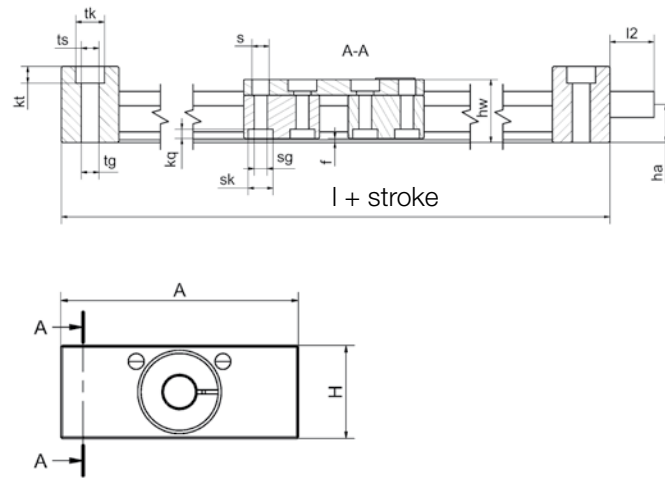

Order example

**SLW-1040**

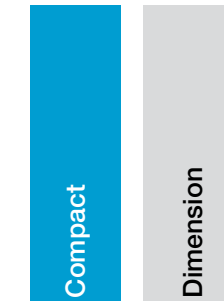

Select versions and accessories online  
▶ [www.igus.eu/drylinSLW](http://www.igus.eu/drylinSLW)

### Technical data and dimensions [mm]

| Part No.             | Form | Max. stroke length [mm] | Weight [kg] | addit. (per 100mm) [kg] | Max. static load capacity |            | Shaft end support material |
|----------------------|------|-------------------------|-------------|-------------------------|---------------------------|------------|----------------------------|
|                      |      |                         |             |                         | axial [N]                 | radial [N] |                            |
| SLW-0630             | ■    | 300                     | 0.2         | 0.08                    | 50                        | 200        | Polymer                    |
| SLW-1040             | ●    | 750                     | 0.7         | 0.10                    | 700                       | 2,800      | Zinc die-casting           |
| SLW-1080             | ●    | 750                     | 0.9         | 0.20                    | 700                       | 2,800      | Aluminium                  |
| SLW-10120            | ●    | 750                     | 1.6         | 0.25                    | 700                       | 2,800      | Aluminium                  |
| SLW-1660             | ●    | 750                     | 1.5         | 0.30                    | 1,200                     | 4,600      | Aluminium                  |
| SLW-16120 <b>New</b> | ●    | 750                     | 1.7         | 0.40                    | 1,200                     | 4,600      | Aluminium                  |
| SLW-2080             | ●    | 1,000                   | 3.0         | 0.40                    | 1,600                     | 6,400      | Aluminium                  |
| SLW-25120            | ●    | 1,250                   | 5.9         | 0.90                    | 2,500                     | 10,000     | Aluminium                  |

| Part No.             | A    | Al <sup>94)</sup> | H  | E1    | E2    | E3    | I   |
|----------------------|------|-------------------|----|-------|-------|-------|-----|
|                      | -0.3 | -0.3              |    | ±0.15 | ±0.15 | ±0.15 |     |
| SLW-0630             | 54   | 60                | 20 | 40    | 45    | 51    | 100 |
| SLW-1040             | 74   | 69                | 29 | 60    | 60    | 56    | 113 |
| SLW-1080             | 108  | 100               | 29 | 94    | 94    | 87    | 144 |
| SLW-10120            | 154  | 100               | 29 | 140   | 140   | 87    | 144 |
| SLW-1660             | 104  | 100               | 37 | 84    | 86    | 82    | 150 |
| SLW-16120 <b>New</b> | 166  | 100               | 37 | 84    | 86    | 82    | 150 |
| SLW-2080             | 134  | 150               | 46 | 116   | 116   | 132   | 206 |
| SLW-25120            | 200  | 150               | 60 | 173   | 173   | 128   | 220 |

<sup>92)</sup> Lead screw end unmachined; <sup>94)</sup> Carriages also in 100, 150, 200 and 250mm lengths available upon request

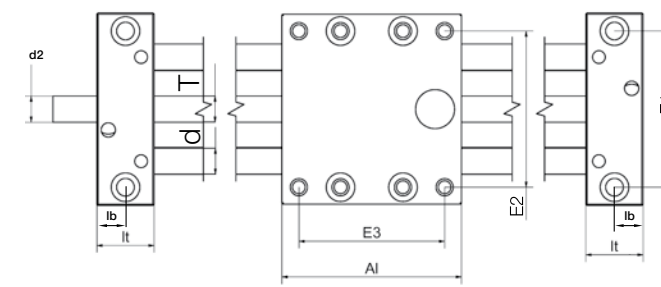

| kt   | Øs   | sk  | sg  | kq  | d  | T      | l2 | d2                    | ha   |
|------|------|-----|-----|-----|----|--------|----|-----------------------|------|
| ±0.1 |      |     |     |     |    |        |    | Standard              |      |
| 6.0  | 4.5  | 7.0 | M4  | 2.0 | 6  | M8     | 15 | M8                    | 9.5  |
| 6.4  | 6.6  | 9.5 | M6  | 4.4 | 10 | Tr10x2 | 17 | Tr10x2 <sup>92)</sup> | 14.5 |
| 6.4  | 6.6  | 9.5 | M6  | 4.4 | 10 | Tr10x2 | 17 | Tr10x2 <sup>92)</sup> | 14.5 |
| M8   | 6.4  | 9.5 | M6  | 4.4 | 10 | Tr10x2 | 17 | Tr10x2 <sup>92)</sup> | 14.5 |
| 8.6  | 9.0  | 11  | M8  | 5.5 | 16 | Tr14x4 | 20 | Tr14x4 <sup>92)</sup> | 18.5 |
| 8.6  | 9.0  | 11  | M8  | 5.5 | 16 | Tr14x4 | 20 | Tr14x4 <sup>92)</sup> | 18.5 |
| 8.6  | 9.0  | 14  | M8  | 5.5 | 20 | Tr18x4 | 26 | 12 h9                 | 23.0 |
| 12.6 | 11.0 | 15  | M10 | 5.0 | 25 | Tr24x5 | 38 | 14 h9                 | 30.0 |

| hw | f   | lt | lb   | tk | ts   | tg     |
|----|-----|----|------|----|------|--------|
| 18 | 1.2 | 20 | 8    | 9  | 7.0  | -      |
| 24 | 1.5 | 22 | 11   | 11 | 6.8  | M8x10  |
| 24 | 1.5 | 22 | 11   | 11 | 6.8  | M8x10  |
| 24 | 1.5 | 22 | 11   | 11 | 6.8  | M8x10  |
| 35 | 1.5 | 25 | 12.5 | 15 | 9.0  | M10x20 |
| 35 | 1.5 | 25 | 12.5 | 15 | 9.0  | M10x20 |
| 44 | 1.5 | 28 | 14   | 15 | 8.6  | M10x15 |
| 55 | 2.5 | 35 | 17.5 | 20 | 13.5 | M16x30 |

## With short carriages



- For small installation spaces
- Save up to 70% installation space with a short linear carriage
- Ideal for multi-carriage or right/left opposite drives

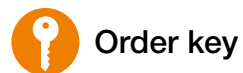

Order key



Order example

**SLWC-0630**

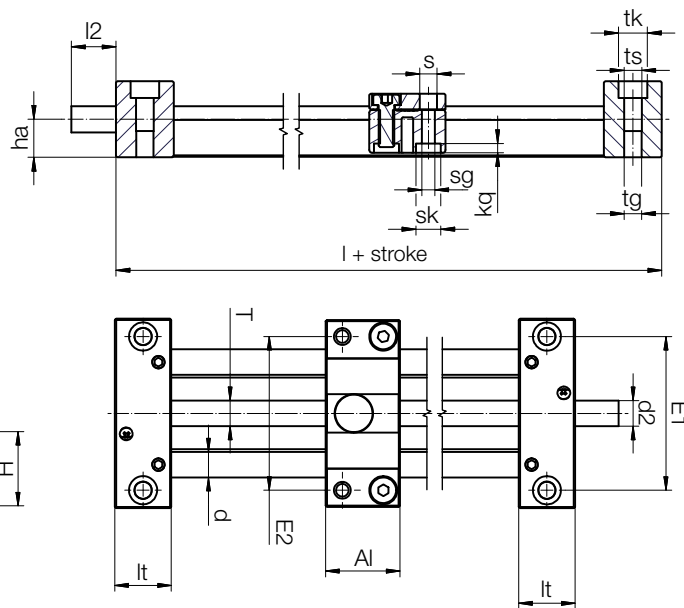
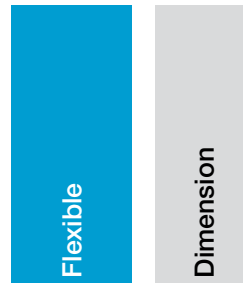

Select versions and accessories online  
► [www.igus.eu/drylinSLWC](http://www.igus.eu/drylinSLWC)

Technical data ► Similar to SLW, page 538

### Dimensions [mm]

| Part No.              | A    | AI   | H  | E1    | E2    | I   | hw | f   | lt   | tk   | ts   |
|-----------------------|------|------|----|-------|-------|-----|----|-----|------|------|------|
|                       | -0.3 | -0.3 |    | ±0.15 | ±0.15 |     |    |     | +0.1 | +0.1 |      |
| SLWC-0630 <b>New</b>  | 54   | 20   | 20 | 40    | 45    | 60  | 18 | 1.2 | 20   | 11   | 6.2  |
| SLWC-1040 <b>New</b>  | 74   | 29   | 29 | 60    | 60    | 73  | 24 | 1.5 | 22   | 11   | 6.8  |
| SLWC-1660 <b>New</b>  | 104  | 36   | 37 | 84    | 86    | 86  | 35 | 1.5 | 25   | 15   | 9.0  |
| SLWC-2080 <b>New</b>  | 134  | 45   | 46 | 116   | 116   | 101 | 44 | 1.5 | 28   | 15   | 8.6  |
| SLWC-25120 <b>New</b> | 200  | 58   | 60 | 173   | 173   | 128 | 55 | 2.5 | 35   | 20   | 13.5 |

| Part No.              | tg     | kt   | Øs   | sk   | sg | kq  | d  | T        | I2 | d2       | d2       | ha   |
|-----------------------|--------|------|------|------|----|-----|----|----------|----|----------|----------|------|
|                       |        | ±0.1 |      |      |    |     |    |          |    | Standard | Optional |      |
| SLWC-0630 <b>New</b>  | M8x12  | 8.0  | 4.5  | 7.0  | M4 | 2.0 | 6  | Tr08x1.5 | 15 | Tr08x1.5 | -        | 9.5  |
| SLWC-1040 <b>New</b>  | M8x10  | 6.4  | 6.6  | 9.5  | M6 | 4.4 | 10 | Tr10x2   | 17 | Tr10x2   | 6 h9     | 14.5 |
| SLWC-1660 <b>New</b>  | M10x20 | 8.6  | 9.0  | 11.0 | M8 | 5.5 | 16 | Tr14x4   | 20 | Tr14x4   | 8 h9     | 18.5 |
| SLWC-2080 <b>New</b>  | M10x15 | 8.6  | 9.0  | 14.0 | M8 | 5.5 | 20 | Tr18x4   | 26 | 12 h9    | -        | 23.0 |
| SLWC-25120 <b>New</b> | M16x30 | 12.6 | 11.0 | 15.0 | M8 | 5.0 | 25 | Tr24x5   | 38 | 12 h9    | 14 h9    | 30.0 |

## Axial pre-load, radial adjustment



- Radial and axial pre-load
- Manual adjustable clearance
- High torsional stability
- Fully supported
- Aluminium drylin® W guide rails, hard-anodised
- Accessories available  
► Page 613
- Lead screw nuts are available separately ► Page 470
- Available with motor



Order key



Order example

**SLW E - 1040 - PL**



Select versions and accessories online  
► [www.igus.eu/drylinSLW](http://www.igus.eu/drylinSLW)

Technical data ► Similar to SLW, page 538

### Dimensions [mm]

| Part No.                 | A    | AI <sup>94)</sup> | H  | E1    | E2    | E3    | I   | hw | f   | lt | lb   | tk | ts  |
|--------------------------|------|-------------------|----|-------|-------|-------|-----|----|-----|----|------|----|-----|
|                          | -0.3 | -0.3              |    | ±0.15 | ±0.15 | ±0.15 |     |    |     |    |      |    |     |
| SLWE-1040-PL             | 74   | 69                | 29 | 60    | 60    | 56    | 113 | 24 | 1.5 | 22 | 11   | 11 | 6.8 |
| SLWE-1080-PL             | 108  | 100               | 29 | 94    | 94    | 87    | 144 | 24 | 1.5 | 22 | 11   | 11 | 6.8 |
| SLWE-10120-PL <b>New</b> | 154  | 100               | 29 | 140   | 140   | 87    | 144 | 24 | 1.5 | 22 | 11   | 11 | 6.8 |
| SLWE-1660-PL             | 104  | 100               | 37 | 84    | 86    | 82    | 150 | 35 | 1.5 | 25 | 12.5 | 15 | 9.0 |
| SLWE-2080-PL             | 134  | 150               | 46 | 116   | 116   | 132   | 206 | 44 | 1.5 | 28 | 14   | 15 | 8.6 |

| Part No.                 | tg     | kt   | Øs  | sk   | sg | kq  | d  | T      | I2 | d2                    | ha   |
|--------------------------|--------|------|-----|------|----|-----|----|--------|----|-----------------------|------|
|                          |        | ±0.1 |     |      |    |     |    |        |    | Standard              |      |
| SLWE-1040-PL             | M8x10  | 6.4  | 6.6 | 9.5  | M6 | 4.4 | 10 | Tr10x2 | 17 | Tr10x2 <sup>92)</sup> | 14.5 |
| SLWE-1080-PL             | M8x10  | 6.4  | 6.6 | 9.5  | M6 | 4.4 | 10 | Tr10x2 | 17 | Tr10x2 <sup>92)</sup> | 14.5 |
| SLWE-10120-PL <b>New</b> | M8x10  | M8   | 6.4 | 9.5  | M6 | 4.4 | 10 | Tr10x2 | 17 | Tr10x2 <sup>92)</sup> | 14.5 |
| SLWE-1660-PL             | M10x20 | 8.6  | 9.0 | 11.0 | M8 | 5.5 | 16 | Tr14x4 | 20 | Tr14x4 <sup>92)</sup> | 18.5 |
| SLWE-2080-PL             | M10x15 | 8.6  | 9.0 | 14.0 | M8 | 5.5 | 20 | Tr18x4 | 26 | 12 h9                 | 23.0 |

<sup>92)</sup> Lead screw end unmachined; <sup>94)</sup> Carriages also in 100, 150, 200 and 250mm lengths available upon request



With ball bearing supported lead screw



- Lower drive force
- Optimised clearance
- Up to 1,500rpm (depending on length and load)
- Aluminium drylin® W guide rails, hard-anodised
- Quiet operation - reduced vibration of the overall system
- Ball bearings in both shaft end supports
- Accessories available ► **Page 613**
- Lead screw nuts are available separately ► **Page 470**
- Available with motor



Select versions and accessories online

► [www.igus.eu/drylinSLW](http://www.igus.eu/drylinSLW)

## Technical data and dimensions [mm]

| Part No.                | Design <sup>96)</sup> | Max. stroke length [mm] | Weight [kg] | additional (per 100mm) [kg] | Max. static load capacity |                       | Max. speed [1/min] |
|-------------------------|-----------------------|-------------------------|-------------|-----------------------------|---------------------------|-----------------------|--------------------|
|                         |                       |                         |             |                             | axial [N]                 | radial [N]            |                    |
| SLW-BB-0630             | ■                     | 300                     | 0.25        | 0.08                        | 100                       | 200                   | 1,000              |
| SLWE-BB-1040            | ●                     | 500                     | 0.90        | 0.10                        | 500                       | 2,000                 | 1,500              |
| SLWE-BB-1080            | ●                     | 500                     | 1.10        | 0.20                        | 500                       | 2,000                 | 1,500              |
| SLWE-BB-1660            | ●                     | 750                     | 1.80        | 0.30                        | 700                       | 2,800                 | 1,500              |
| SLW-BB-16120 <b>New</b> | ●                     | 750                     | 1.90        | 0.40                        | 700                       | 2,800 <sup>186)</sup> | 1,500              |
| SLWE-BB-2080            | ●                     | 900                     | 3.30        | 0.40                        | 1,250                     | 5,000                 | 1,500              |
| SLW-BB-25120            | ●                     | 1,000                   | 3.30        | 0.40                        | 1,500                     | 6,000                 | 1,200              |

## Dimensions [mm]

| Part No.                | A    | Al   | H  | E1    | E2    | E3    |
|-------------------------|------|------|----|-------|-------|-------|
|                         | -0.3 | -0.3 |    | ±0.15 | ±0.15 | ±0.15 |
| SLW-BB-0630             | 54   | 60   | 20 | 40    | 45    | 51    |
| SLWE-BB-1040            | 74   | 69   | 29 | 60    | 60    | 56    |
| SLWE-BB-1080            | 108  | 100  | 29 | 94    | 94    | 87    |
| SLWE-BB-1660            | 104  | 100  | 37 | 84    | 86    | 82    |
| SLW-BB-16120 <b>New</b> | 166  | 150  | 37 | 146   | 148   | 132   |
| SLWE-BB-2080            | 134  | 150  | 46 | 116   | 116   | 132   |
| SLW-BB-25120            | 200  | 150  | 60 | 173   | 173   | 128   |

<sup>95)</sup> Version with turned lead screw end available

<sup>96)</sup> Double rail, square ► **Page 78**, round ► **Page 84**

<sup>186)</sup> Only bearing load without consideration of possible shaft deflection

<sup>187)</sup> Other carriage lengths: 200mm and 250mm

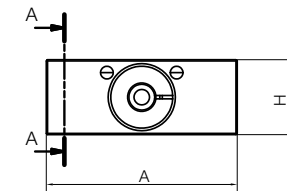
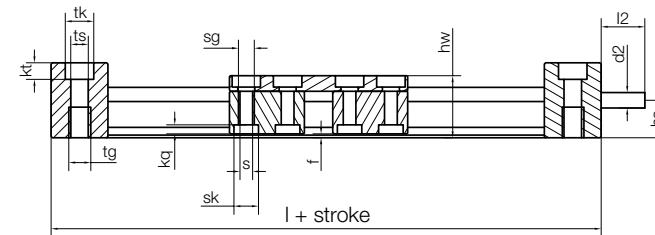
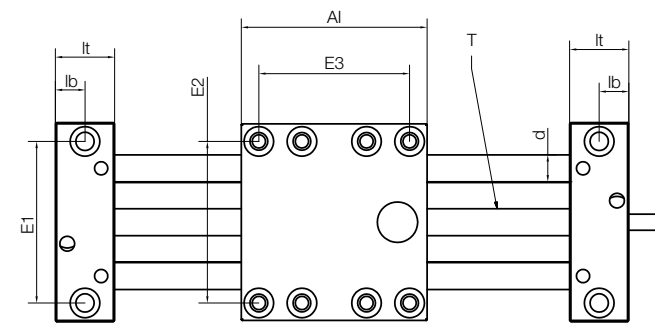

Order key



Order example

**SLW E -BB-1040**



| Max. feed rate [m/min] | kt ±0.1 | sk   | sg  | kq  | Øs   | d  | T       | l2 | d2 Standard | d2 <sup>95)</sup> | ha   |
|------------------------|---------|------|-----|-----|------|----|---------|----|-------------|-------------------|------|
| 1.5                    | 8.0     | 7.0  | M4  | 2.0 | 4.5  | 6  | Tr8x1.5 | 15 | Tr08x1.5    | -                 | 9.5  |
| 3.0                    | 6.4     | 9.5  | M6  | 4.4 | 6.6  | 10 | Tr10x2  | 17 | Tr10x2      | 6 h9              | 14.5 |
| 3.0                    | 6.4     | 9.5  | M6  | 4.4 | 6.6  | 10 | Tr10x2  | 17 | Tr10x2      | 6 h9              | 14.5 |
| 6.0                    | 8.6     | 11.0 | M8  | 5.5 | 9.0  | 16 | Tr14x4  | 20 | Tr14x4      | 8 h9              | 18.5 |
| 4.5                    | 8.6     | 11.0 | M8  | 5.5 | 9.0  | 16 | Tr14x3  | 20 | Tr14x3      | 8 h9              | 18.5 |
| 6.0                    | 8.6     | 14.0 | M8  | 5.5 | 9.0  | 20 | Tr18x4  | 26 | 12 h9       | -                 | 23.0 |
| 6.0                    | 12.6    | 15   | M10 | 5.0 | 11.0 | 25 | Tr24x5  | 38 | 14 h9       | -                 | 30.0 |

| l   | hw | f   | lt | lb   | tk | ts   | tg     |
|-----|----|-----|----|------|----|------|--------|
| 112 | 18 | 1.2 | 26 | 14.0 | 11 | 6.8  | M8x12  |
| 129 | 24 | 1.5 | 30 | 19.0 | 11 | 6.8  | M8x10  |
| 160 | 24 | 1.5 | 30 | 19.0 | 11 | 6.8  | M8x10  |
| 170 | 35 | 1.5 | 35 | 22.5 | 15 | 9.0  | M10x20 |
| 200 | 35 | 1.5 | 35 | 17.5 | 15 | 9.0  | M10x20 |
| 230 | 44 | 1.5 | 40 | 26.0 | 15 | 8.6  | M10x15 |
| 220 | 55 | 2.5 | 49 | 17.5 | 20 | 13.5 | M16x30 |





- High torsional stability
- Aluminium drylin® W guide rails, hard-anodised
- BB version with ball bearing supported lead screw available
- Accessories available ► **Page 613**
- Lead screw nuts are available separately ► **Page 470**

Select versions and accessories online  
► [www.igus.eu/drylinSLW](http://www.igus.eu/drylinSLW)

The complete overview of the available lead screw sizes can be found on ► **Page 510**



Order example

### SLW S - 0630 - 08x15

|         |                   |           |       |
|---------|-------------------|-----------|-------|
| Compact | High helix thread | Dimension | Pitch |
|---------|-------------------|-----------|-------|

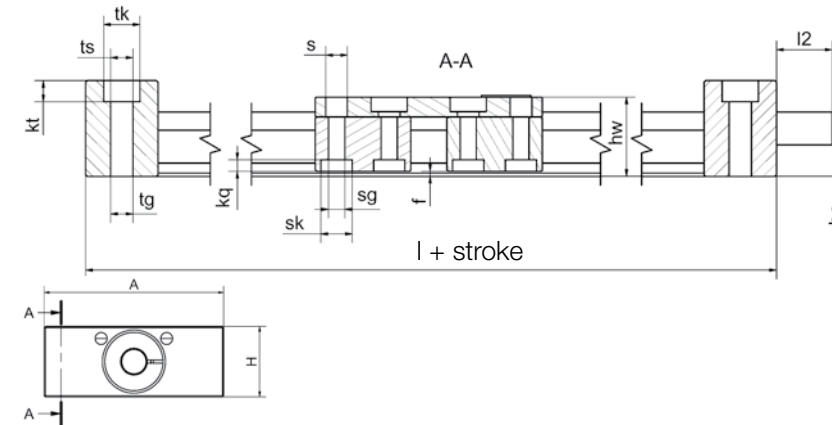
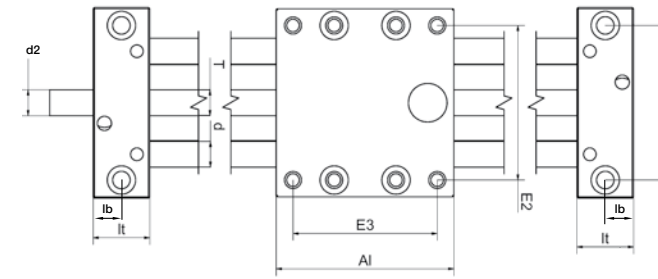

### Technical data and dimensions [mm]

| Part No.         | Design <sup>96)</sup> | Max. stroke length | Weight [kg] | addit. (per 100mm) [kg] | Max. static load capacity |            |
|------------------|-----------------------|--------------------|-------------|-------------------------|---------------------------|------------|
|                  |                       |                    |             |                         | axial [N]                 | radial [N] |
| SLWS-0630-08x15  | ■                     | 300                | 0.2         | 0.08                    | 50                        | 200        |
| SLWS-1040-10x12  | ●                     | 750                | 0.7         | 0.10                    | 100                       | 400        |
| SLWS-1040-10x50  | ●                     | 750                | 0.7         | 0.10                    | 100                       | 400        |
| SLWS-1080-10x12  | ●                     | 750                | 0.9         | 0.20                    | 100                       | 400        |
| SLWS-1080-10x50  | ●                     | 750                | 0.9         | 0.20                    | 100                       | 400        |
| SLWS-16120       | New ●                 | 750                | 1.5         | 0.30                    | 250                       | 1,000      |
| SLWS-2080-18x100 | ●                     | 750                | 0.9         | 0.20                    | 400                       | 1,600      |
| SLWS-25120       | New ●                 | 1,250              | 5.9         | 0.90                    | 1,000                     | 4,000      |

| Part No.         | lt     | lb   | tk | ts   | tg     | kt ±0.1 | Øs   |
|------------------|--------|------|----|------|--------|---------|------|
| SLWS-0630-08x15  | 20     | 10.0 | 9  | 7.0  | -      | 6.0     | 4.5  |
| SLWS-1040-10x12  | 22     | 11.0 | 11 | 6.8  | M8x12  | 6.4     | 6.6  |
| SLWS-1040-10x50  | 22     | 11.0 | 11 | 6.8  | M8x10  | 6.4     | 6.6  |
| SLWS-1080-10x12  | 22     | 11.0 | 11 | 6.8  | M8x10  | 6.4     | 6.6  |
| SLWS-1080-10x50  | 22     | 11.0 | 11 | 6.8  | M8x10  | 6.4     | 6.6  |
| SLWS-16120       | New 25 | 12.5 | 15 | 9.0  | M10x20 | 8.6     | 9.0  |
| SLWS-2080-18x100 | 28     | 14.0 | 15 | 8.6  | M10x15 | 12.6    | 11.0 |
| SLWS-25120       | New 49 | 17.5 | 20 | 13.5 | M16x30 | 12.6    | 11.0 |

| A    | AI   | H  | E1    | E2    | E3    | I   | hw   | f   |
|------|------|----|-------|-------|-------|-----|------|-----|
| -0.3 | -0.3 |    | ±0.15 | ±0.15 | ±0.15 |     |      |     |
| 54   | 60   | 20 | 40    | 45    | 51    | 100 | 17.5 | 1.2 |
| 74   | 69   | 29 | 60    | 60    | 56    | 113 | 24   | 1.5 |
| 74   | 69   | 29 | 60    | 60    | 56    | 113 | 24   | 1.5 |
| 108  | 100  | 29 | 94    | 94    | 87    | 144 | 24   | 1.5 |
| 108  | 100  | 29 | 94    | 94    | 87    | 144 | 24   | 1.5 |
| 166  | 150  | 37 | 146   | 148   | 132   | 200 | 35   | 1.5 |
| 134  | 150  | 46 | 116   | 116   | 132   | 206 | 44   | 1.5 |
| 200  | 150  | 60 | 173   | 173   | 128   | 220 | 55   | 2.5 |

| sk   | sg  | kq  | d  | T        | l2 | d2                     | ha   |
|------|-----|-----|----|----------|----|------------------------|------|
| 7.0  | M4  | 2.0 | 6  | Ds08x15  | 15 | Ds8x15 <sup>92)</sup>  | 9.5  |
| 9.5  | M6  | 4.4 | 10 | Ds10x12  | 17 | Ds10x12 <sup>92)</sup> | 14.5 |
| 9.5  | M6  | 4.4 | 10 | Ds10x50  | 17 | Ds10x50 <sup>92)</sup> | 14.5 |
| 9.5  | M6  | 4.4 | 10 | Ds10x12  | 17 | Ds10x12 <sup>92)</sup> | 14.5 |
| 9.5  | M6  | 4.4 | 10 | Ds10x50  | 17 | Ds10x50 <sup>92)</sup> | 14.5 |
| 11.0 | M8  | 5.5 | 16 | Tr14x3   | 20 | Tr14x3                 | 18.5 |
| 15.0 | M8  | 5.0 | 25 | Ds18x100 | 38 | 14 h9                  | 30.0 |
| 15.0 | M10 | 5.0 | 25 | Tr24x5   | 38 | 14 h9                  | 30.0 |

<sup>92)</sup> Lead screw end unmachined <sup>96)</sup> Double rails, square ► **Page 78**, round ► **Page 84**

## With protected lead screw



- drylin® W profile rail as a protective mechanism
- Available with pitches 10x2, 10x12, 10x25, 10x50
- Low profile design
- Available with motor

### Order key

Order example

**SLW-BB-PT-1040**

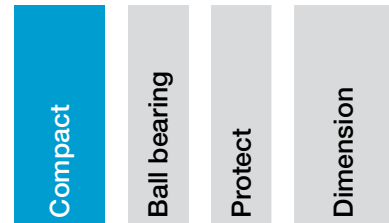

Select versions and accessories online  
▶ [www.igus.eu/drylinSLW](http://www.igus.eu/drylinSLW)

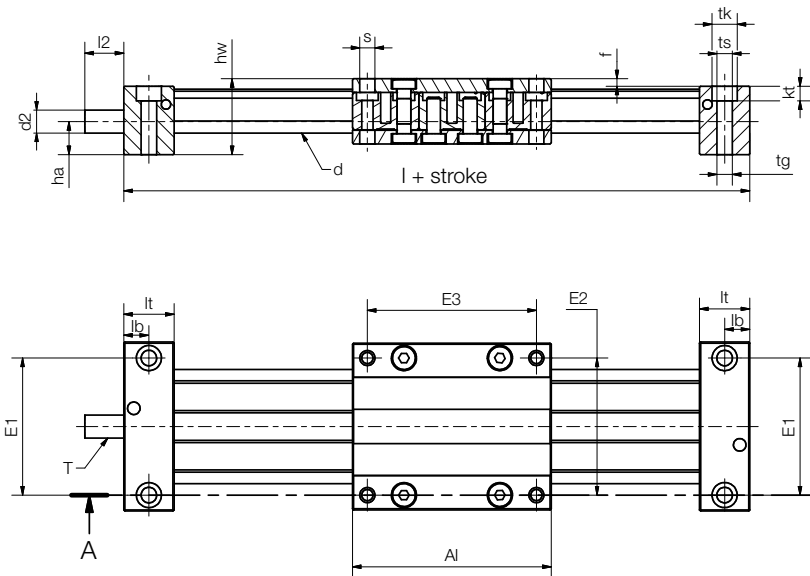

### Technical data

| Part No.       | Max. stroke length [mm] | Weight [kg] | additional (per 100mm) [kg] | Max. static load capacity |                           | Shaft end support material |
|----------------|-------------------------|-------------|-----------------------------|---------------------------|---------------------------|----------------------------|
|                |                         |             |                             | axial [N]                 | radial <sup>97)</sup> [N] |                            |
| SLW-PT-1040    | 750                     | 0.75        | 0.20                        | 700                       | 2,000                     | Aluminium                  |
| SLW-BB-PT-1040 | 750                     | 1.10        | 0.20                        | 500                       | 2,000                     | Aluminium                  |

### Dimensions [mm]

| Part No.       | A  | Al | H  | E1/E2 |       | E3  | l     | hw   | f  | lt | lb | tk  | ts    | tg |
|----------------|----|----|----|-------|-------|-----|-------|------|----|----|----|-----|-------|----|
|                |    |    |    | ±0.15 | ±0.15 |     |       |      |    |    |    |     |       |    |
| SLW-PT-1040    | 74 | 87 | 29 | 60    | 74    | 131 | 33.25 | 3.25 | 22 | 11 | 11 | 6.8 | M8x10 |    |
| SLW-BB-PT-1040 | 74 | 87 | 29 | 60    | 74    | 147 | 33.25 | 3.25 | 30 | 19 | 11 | 6.8 | M8x10 |    |

| Part No.       | kt ±0.1 | d  | T      | l2 | d2     | d2 <sup>98)</sup> | ha    |
|----------------|---------|----|--------|----|--------|-------------------|-------|
|                |         |    |        |    |        |                   |       |
| SLW-BB-PT-1040 | 6.4     | 10 | Tr10x2 | 17 | Tr10x2 | 6 h9              | 14.50 |

<sup>97)</sup> Depends on load and rotation speed <sup>98)</sup> Thread/remaining thread visible

## Dual action linear system



- Carriages can be controlled separately
- Different lead screw pitches can be applied
- Separate manual adjustment of carriages
- Design flexibility
- Clearance adjustment (optional)

### Order key

Order example

**SLW T -1080**

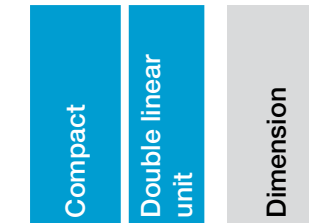

Options:  
BB Ball bearings

Select versions and accessories online  
▶ [www.igus.eu/drylinSLW](http://www.igus.eu/drylinSLW)

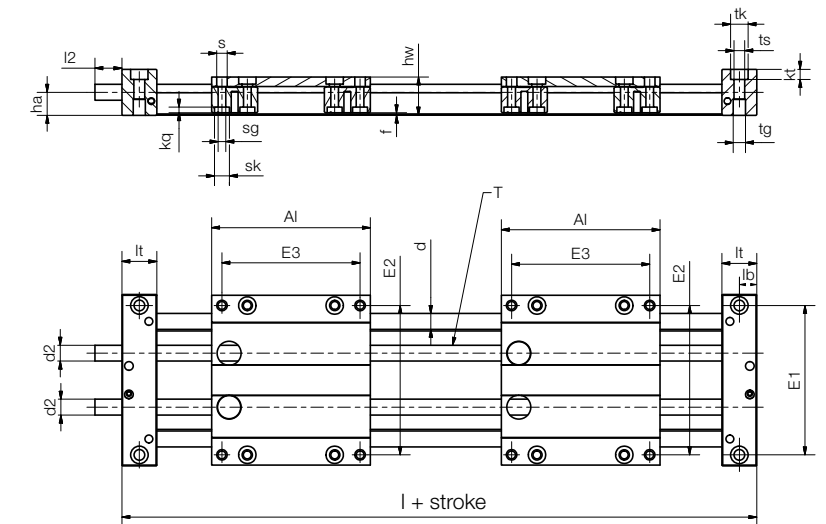
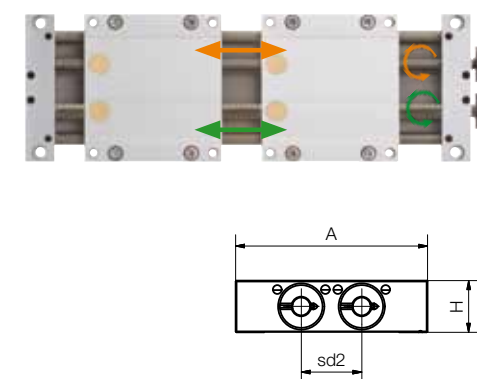

### Technical data

| Part No.                 | Max. stroke length [mm] | Weight [kg] | additional (per 100mm) [kg] | Max. static load capacity |            | Shaft end support material |
|--------------------------|-------------------------|-------------|-----------------------------|---------------------------|------------|----------------------------|
|                          |                         |             |                             | axial [N]                 | radial [N] |                            |
| SLWT-1080                | 750                     | 1.6         | 0.25                        | 700                       | 2,800      | Aluminium                  |
| SLWT-16120 <b>New</b>    | 750                     | 1.8         | 0.50                        | 1,200                     | 4,600      | Aluminium                  |
| SLWT-BB-1080             | 750                     | 1.6         | 0.25                        | 700                       | 2,800      | Aluminium                  |
| SLWT-BB-16120 <b>New</b> | 750                     | 2.1         | 0.50                        | 700                       | 2,800      | Aluminium                  |

### Dimensions [mm]

| Part No.                 | A   | Al  | H  | E1  | E2  | E3  | l   | hw | f ±0.1 | lt | tk | ts  | tg ±0.1 | lb   |
|--------------------------|-----|-----|----|-----|-----|-----|-----|----|--------|----|----|-----|---------|------|
|                          |     |     |    |     |     |     |     |    |        |    |    |     |         |      |
| SLWT-1080                | 108 | 100 | 29 | 94  | 94  | 87  | 244 | 24 | 1.5    | 22 | 11 | 6.8 | M8x10   | 11.0 |
| SLWT-16120 <b>New</b>    | 166 | 150 | 37 | 146 | 148 | 132 | 200 | 35 | 1.5    | 25 | 15 | 9.0 | M10x20  | 12.5 |
| SLWT-BB-1080             | 108 | 100 | 29 | 94  | 94  | 87  | 244 | 24 | 1.5    | 30 | 11 | 6.8 | M8x10   | 19.0 |
| SLWT-BB-16120 <b>New</b> | 166 | 150 | 37 | 146 | 148 | 132 | 220 | 35 | 1.5    | 35 | 15 | 9.0 | M10x20  | 17.5 |

| Part No.                 | kt ±0.1 | sk   | Øs  | sg | kq  | d  | T                     | l2 | d2       |                      | ha    | sd2 |
|--------------------------|---------|------|-----|----|-----|----|-----------------------|----|----------|----------------------|-------|-----|
|                          |         |      |     |    |     |    |                       |    | Standard | Alternative          |       |     |
| SLWT-1080                | 6.4     | 9.5  | 6.6 | M6 | 4.4 | 10 | Tr10x2 <sup>92)</sup> | 17 | Tr10x2   | 6 h9                 | 14.50 | 34  |
| SLWT-16120 <b>New</b>    | 8.6     | 11.0 | 9.0 | M8 | 5.5 | 16 | Tr14x3                | 20 | Tr14x3   | 8 h9 <sup>186)</sup> | 18.50 | 65  |
| SLWT-BB-1080             | 6.4     | 9.5  | 6.6 | M6 | 4.4 | 10 | Tr10x2 <sup>92)</sup> | 17 | Tr10x2   | 6 h9                 | 14.50 | 34  |
| SLWT-BB-16120 <b>New</b> | 8.6     | 11.0 | 9.0 | M8 | 5.5 | 16 | Tr14x3                | 20 | Tr14x3   | 8 h9 <sup>186)</sup> | 18.50 | 65  |

<sup>92)</sup> Lead screw end unmachined; <sup>186)</sup> Only bearing load without consideration of possible shaft deflection

## Made of stainless steel



- Stainless steel version with corrosion-resistant steel components (AISI 303, AISI 316 and (AISI 316Ti)
- Choice of bearing material:  
iglidur® J = Standard  
iglidur® A180 = FDA-compliant  
iglidur® X = High temperature up to +150°C<sup>117)</sup>
- Accessories available  
▶ Page 613

### Order key

Order example

## SLW-ES J-1040

|         |                 |                  |           |
|---------|-----------------|------------------|-----------|
| Compact | Stainless steel | Bearing material | Dimension |
|---------|-----------------|------------------|-----------|

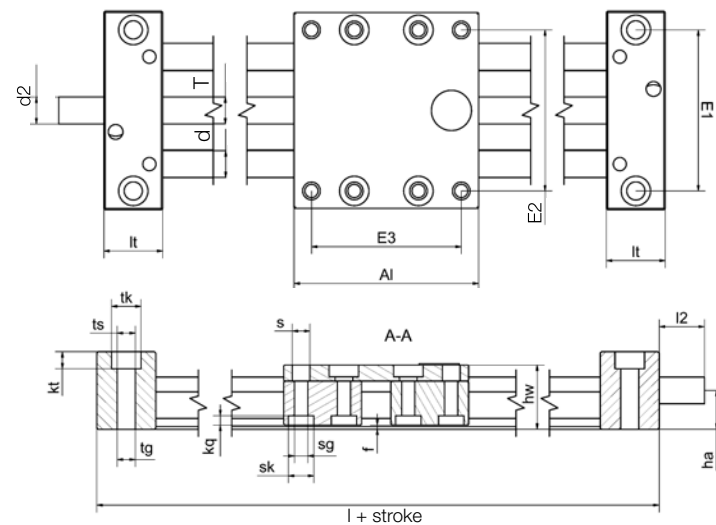

Select versions and accessories online  
▶ [www.igus.eu/drylinSLW](http://www.igus.eu/drylinSLW)

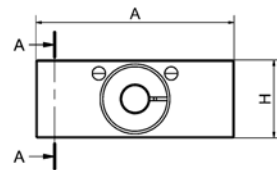

### Technical data

| Part No.        | Shaft Ø<br>[mm] | Max. stroke length<br>[mm] | Weight<br>[kg] | additional<br>(per 100mm)<br>[kg] | Max. stat. load capacity |            |
|-----------------|-----------------|----------------------------|----------------|-----------------------------------|--------------------------|------------|
|                 |                 |                            |                |                                   | axial [N]                | radial [N] |
| SLW-ESJ-1040    | 10              | 750                        | 1.4            | 0.2                               | 700                      | 2,800      |
| SLW-ESX-1040    | 10              | 750                        | 1.4            | 0.2                               | 700                      | 2,800      |
| SLW-ESA180-1040 | 10              | 750                        | 1.4            | 0.2                               | 700                      | 2,800      |
| SLW-ESJ-2080    | 20              | 1,000                      | 5.7            | 0.64                              | 1,600                    | 6,400      |
| SLW-ESA180-2080 | 20              | 1,000                      | 5.7            | 0.64                              | 1,600                    | 6,400      |

### Dimensions [mm]

| Part No.    | A    | Al   | H  | E1    | E2    | E3    | l   | hw | f   | lt | lb | tk | ts  | tg     |
|-------------|------|------|----|-------|-------|-------|-----|----|-----|----|----|----|-----|--------|
|             | -0.3 | -0.3 |    | ±0.15 | ±0.15 | ±0.15 |     |    |     |    |    |    |     |        |
| SLW-ES-1040 | 74   | 100  | 29 | 60    | 60    | 87    | 144 | 24 | 1.5 | 22 | 11 | 11 | 6.8 | M8x10  |
| SLW-ES-2080 | 134  | 150  | 46 | 116   | 116   | 132   | 206 | 44 | 1.5 | 28 | 14 | 15 | 8.6 | M10x15 |

  

| Part No.    | kt   | Øs  | sk  | sg | kq  | d  | T      | l2 | d2                    | ha   |
|-------------|------|-----|-----|----|-----|----|--------|----|-----------------------|------|
|             | ±0.1 |     |     |    |     |    |        |    | Standard              |      |
| SLW-ES-1040 | 6.4  | 6.6 | 9.5 | M6 | 4.4 | 10 | Tr10x2 | 17 | Tr10x2 <sup>92)</sup> | 14.5 |
| SLW-ES-2080 | 8.6  | 9.0 | 14  | M8 | 5.5 | 20 | Tr18x4 | 26 | 12 h9                 | 23.0 |

<sup>92)</sup> Lead screw end unmachined

<sup>117)</sup> In the event of severe temperature fluctuations during transport, storage and use, thermal expansion effects cannot be ruled out

## Notes

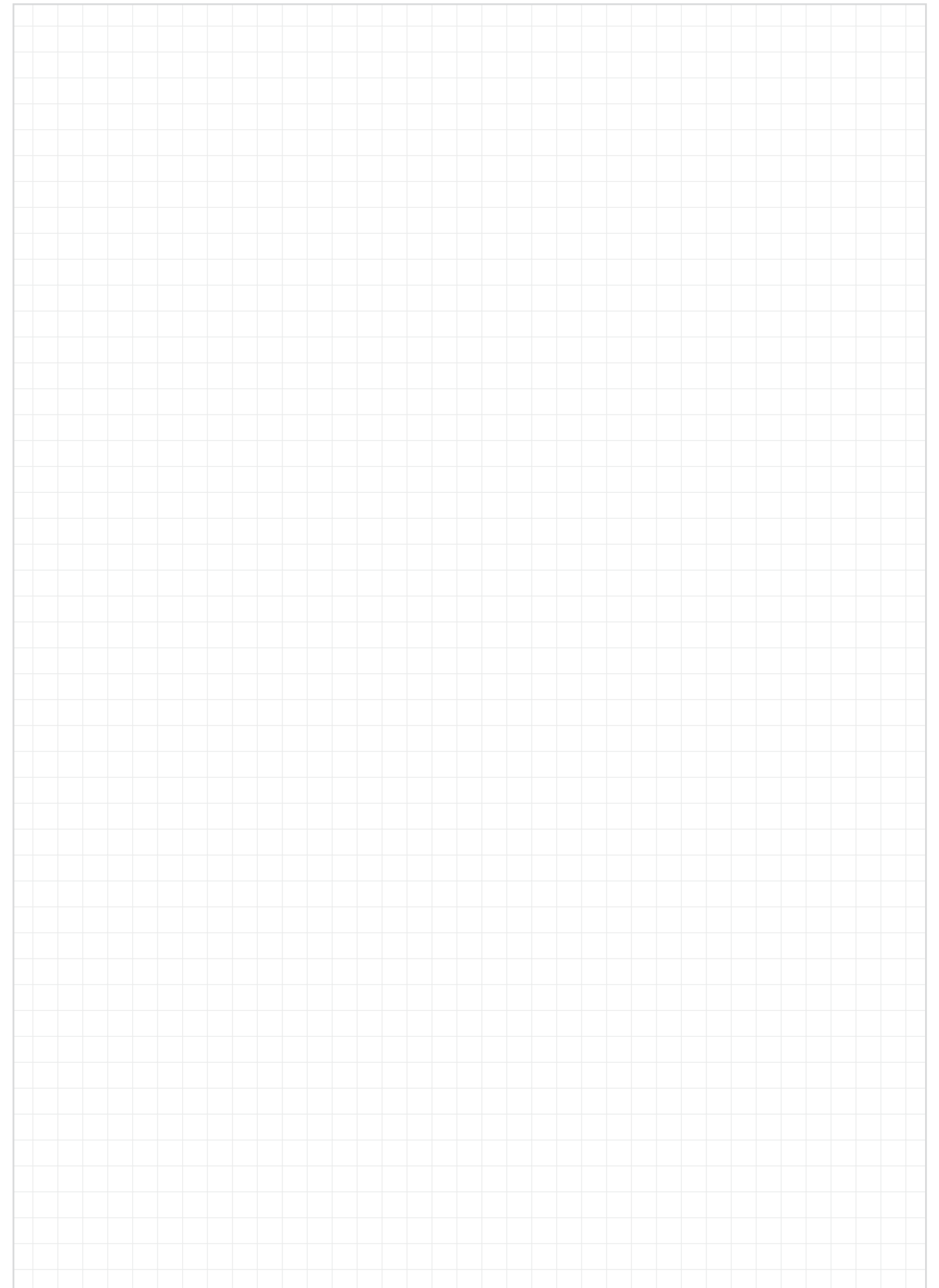

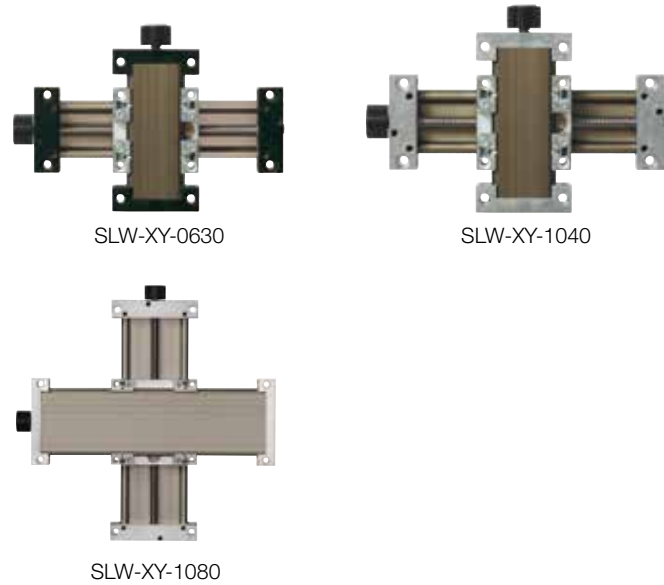

- Aluminium drylin® W guide rails, hard-anodised
- Pre-load SLWE-XY-PL version also available (optional, sizes: 1040/1080)
- Accessories available ▶ **Page 613**

Select versions and accessories online  
▶ [www.igus.eu/drylinSLW](http://www.igus.eu/drylinSLW)

### Dimensions [mm]

| Part No.                | Max. stroke length [mm] | A    | Al  | H    | E1    | E2    |
|-------------------------|-------------------------|------|-----|------|-------|-------|
|                         |                         | -0.3 |     |      | ±0.15 | ±0.15 |
| SLW-XY-0630             | 150                     | 54   | 54  | 38.0 | 40    | 45    |
| SLW-XY-0660 <b>New</b>  | 150                     | 85   | 85  | 37.4 | 71    | 76    |
| SLW-XY-1040             | 300                     | 74   | 73  | 48.0 | 60    | 60    |
| SLW-XY-1080             | 300                     | 108  | 107 | 48.0 | 94    | 94    |
| SLW-XY-1660 <b>New</b>  | 400                     | 104  | 104 | 72.5 | 84    | 86    |
| SLW-XY-16120 <b>New</b> | 500                     | 166  | 166 | 72.5 | 146   | 148   |
| SLW-XY-2080 <b>New</b>  | 500                     | 134  | 134 | 82.0 | 116   | 116   |

### Dimensions [mm]

| Part No.                | sg | d  | T        | l1 | d1       |
|-------------------------|----|----|----------|----|----------|
|                         |    |    |          |    | Standard |
| SLW-XY-0630             | M4 | 5  | M8       | 15 | M8       |
| SLW-XY-0660 <b>New</b>  | M4 | 5  | Tr08x1.5 | 15 | Tr08x1.5 |
| SLW-XY-1040             | M6 | 10 | Tr10x2   | 17 | Tr10x2   |
| SLW-XY-1080             | M6 | 10 | Tr10x2   | 17 | Tr10x2   |
| SLW-XY-1660 <b>New</b>  | M8 | 16 | Tr14x4   | 20 | Tr14x4   |
| SLW-XY-16120 <b>New</b> | M8 | 16 | Tr14x3   | 20 | Tr14x3   |
| SLW-XY-2080 <b>New</b>  | M8 | 20 | Tr18x4   | 26 | 12 h9    |

The hand wheel can be ordered left or right-mounted in the y-direction.

Left: SLW-XY-1040-L-200-300 for 200mm stroke length on the x-axis and 300mm on the y-axis

Right: SLW-XY-1040-R-200-300 for 200mm stroke length on the x-axis and 300mm on the y-axis

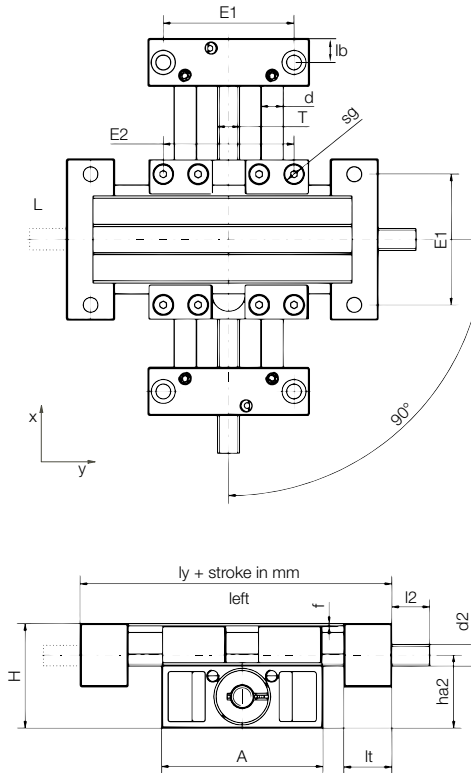

### Order key

Order example

## SLW-XY-1040-PL

|         |          |           |         |   |
|---------|----------|-----------|---------|---|
| Compact | XY table | Dimension | Preload | Options:<br>Preload<br>optional with sizes<br>1040 and 1080 |
|---------|----------|-----------|---------|---|

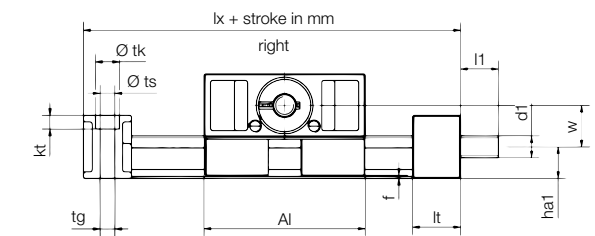

| Base length lx | Base length ly | f   | lt | lb   | tk | ts  | tg     | kt  |
|----------------|----------------|-----|----|------|----|-----|--------|-----|
| 94             | 94             | 1.5 | 20 | 10.0 | 9  | 7.0 | –      | 6.0 |
| 125            | 125            | 1.5 | 20 | 10.0 | 11 | 6.6 | –      | 8.0 |
| 117            | 117            | 1.5 | 22 | 11.0 | 11 | 6.8 | M8x10  | 6.4 |
| 151            | 151            | 1.5 | 22 | 11.0 | 11 | 6.8 | M8x10  | 6.4 |
| 154            | 154            | 1.5 | 25 | 12.5 | 15 | 9.0 | M10x20 | 8.6 |
| 216            | 216            | 1.5 | 25 | 12.5 | 15 | 9.0 | M10x20 | 8.6 |
| 190            | 190            | 1.5 | 28 | 14.0 | 15 | 8.6 | M10x15 | 8.6 |

| d1 Alternative | l2 | d2 Standard | d2 Alternative | ha1  | ha2  | W ha2-ha1 |
|----------------|----|-------------|----------------|------|------|-----------|
| –              | 15 | M8          | –              | 9.5  | 28.5 | 18.4      |
| –              | 15 | Tr08x1.5    | –              | 9.5  | 28.0 | 18.5      |
| 6 h9           | 17 | Tr10x2      | 6 h9           | 14.5 | 33.5 | 19.0      |
| 6 h9           | 17 | Tr10x2      | 6 h9           | 14.5 | 33.5 | 19.0      |
| 8 h9           | 20 | Tr14x4      | 8 h9           | 18.5 | 54.0 | 35.5      |
| 8 h9           | 20 | Tr14x3      | 8 h9           | 18.5 | 54.0 | 35.5      |
| –              | 26 | 12 h9       | –              | 23.0 | 59.0 | 36.0      |





- For manual adjustments
- High torsional stability
- Structure entirely made from 316 stainless steel materials
- Chemical and corrosion-resistant
- Accessories available ► Page 613

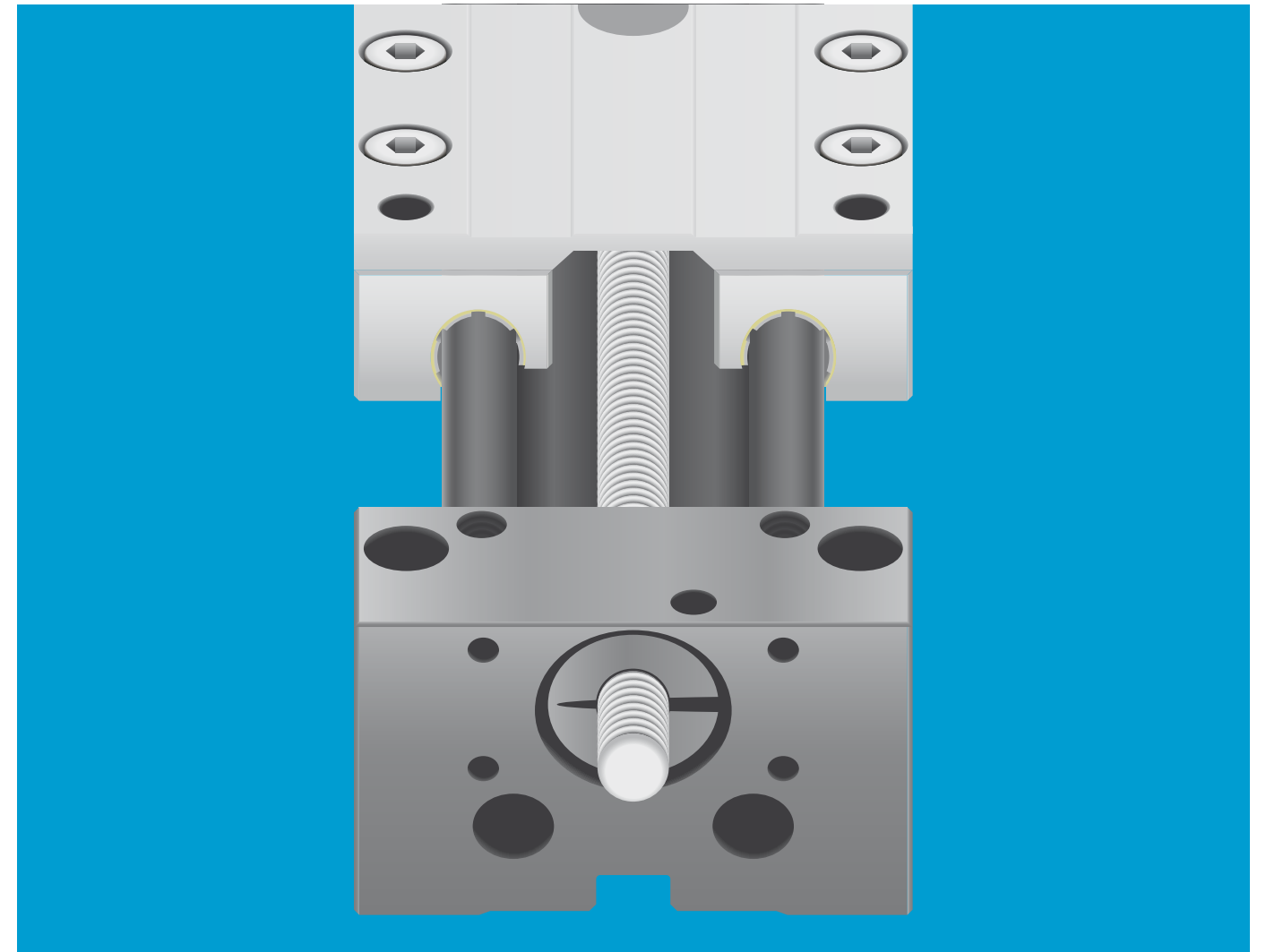
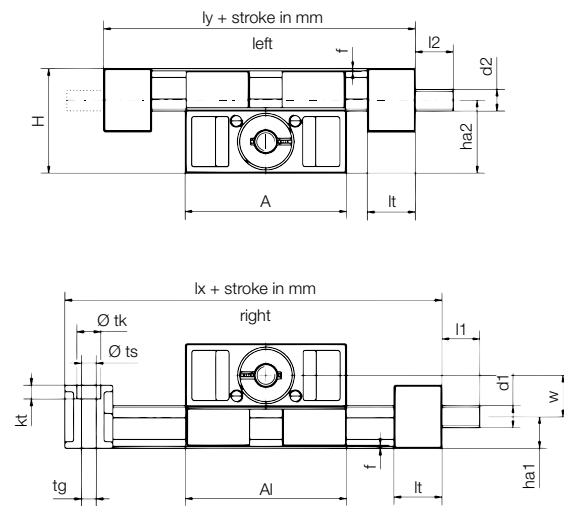
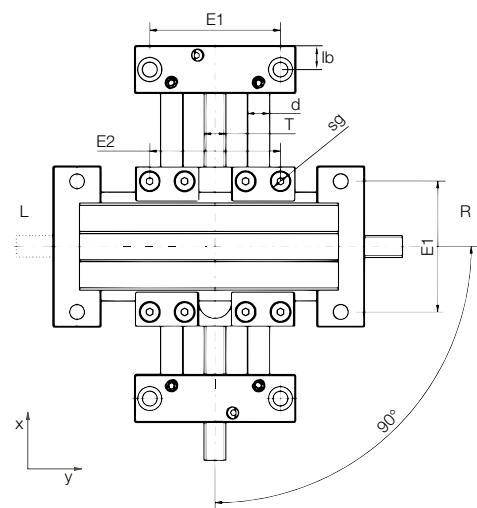
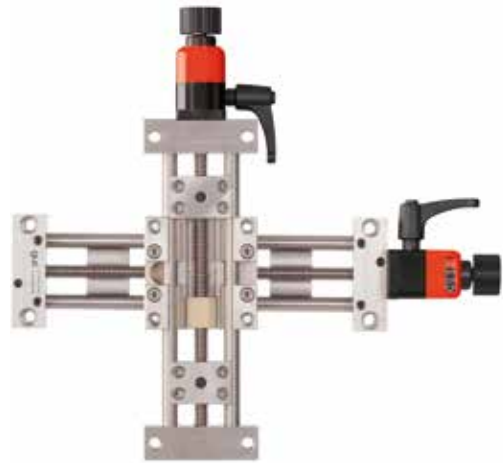

Select versions and accessories online  
► [www.igus.eu/drylinSLW](http://www.igus.eu/drylinSLW)

Dimensions [mm]

| Part No.        | Max. stroke length [mm] | A    | Al | H  | E1 | E2    | Base length lx | Base length ly | f   | lt  | lb | tk | ts   | tg  | kt    |     |
|-----------------|-------------------------|------|----|----|----|-------|----------------|----------------|-----|-----|----|----|------|-----|-------|-----|
| SLW-XY-ESJ-1040 | 300                     | -0.3 | 74 | 73 | 48 | ±0.15 | ±0.15          | 117            | 117 | 1.5 | 22 | 11 | ±0.1 | 6.8 | M8x10 | 6.4 |

Dimensions [mm]

| Part No.        | sg | d  | T      | l1 | d1 Standard | d1 Alternative | l2 | d2 Standard | d2 Alternative | ha1  | ha2  | W  |
|-----------------|----|----|--------|----|-------------|----------------|----|-------------|----------------|------|------|----|
| SLW-XY-ESJ-1040 | M6 | 10 | Tr10x2 | 17 | Tr10x2      | 6 h9           | 17 | Tr10x2      | 6 h9           | 14.5 | 33.5 | 19 |

The hand wheel can be ordered left or right-mounted in the y-direction.

Left: SLW-XY-ESJ-1040-L-200-300 for 200mm stroke length on the x-axis and 300mm on the y-axis

Right: SLW-XY-ESJ-1040-R-200-300 for 200mm stroke length on the x-axis and 300mm on the y-axis

## drylin® general drive technology - SAW linear modules

Lubrication-free linear modules based on drylin® W guides

Drive: Trapezoidal or high helix lead screw

Robust design

Ready-to-install stepper or DC motors

Ball bearing



Compact high design



Shaft end supports made from black anodised aluminium

Lead screws with ball bearings, standard

Extremely torsion-resistant drylin® W high profile rail made from hard-anodised aluminium

Lubrication and maintenance-free drylin® lead screw nuts

The carriages consist of four drylin® W individual bearing housings equipped with lubrication-free drylin® liners

Mounting plates made from anodised aluminium, available in different lengths

Adapter plates for linear robot solutions available

Lead screw material steel/stainless steel/aluminium

Drive: Self-locking trapezoidal thread or fast adjust high helix thread

Configurable with motor as a ready-to-install linear drive

## Lubrication-free linear modules - drylin® SAW

The drylin® W high profile provides the torsion-resistant base for the linear axes of the SAW series. Thanks to the ball bearing supported lead screw and high profile design, the SAW linear modules are perfectly suitable for the direct connection to stepper or DC motors. Slots in profile sections enable initiators to be freely positioned and, at the same time, enable set-up as a multi-axis linear robot by means of suitable adapter plates.

- Optimised unit for motor connection
- drylin® W high profile with variable mounting options using clamping elements or slot nuts
- For manual or electrical adjustments
- Ideal for single and/or multi-axial constructions

### Typical application areas

- Positioning functions
- 3D scanner
- Format adjustments
- Linear robot structures
- Height adjustments

 **Available in 3-8 days**  
Detailed information about delivery time online.

 **Price breaks online**  
No minimum order value. No minimum order quantity

 **Carriage lengths: 60-250mm**  
**Carriage widths: 54-107mm**  
**Stroke lengths: up to 750mm**

 **Product finder**  
▶ [www.igus.eu/saw-productfinder](http://www.igus.eu/saw-productfinder)

Ball bearings



### SAW linear module

- Robust high design in 4 sizes
  - Drive: Trapezoidal or high helix lead screw
  - For manual positioning or motorised operation
- ▶ Page 556



### SAWC linear module

- Compact short design
  - With integrated drylin® lead screw motor
  - Optimised ratio of useful length to total length
- ▶ Page 558

Robust design



- Trapezoidal or high helix threads
- Ball bearing supported lead screw
- Rail profile in high design, extremely torsion-resistant
- Aluminium drylin® W guide rails, hard-anodised
- High strength
- Cost-effective and 100% lubrication-free
- Accessories available ► Page 613
- Lead screw nuts are available separately ► Page 470

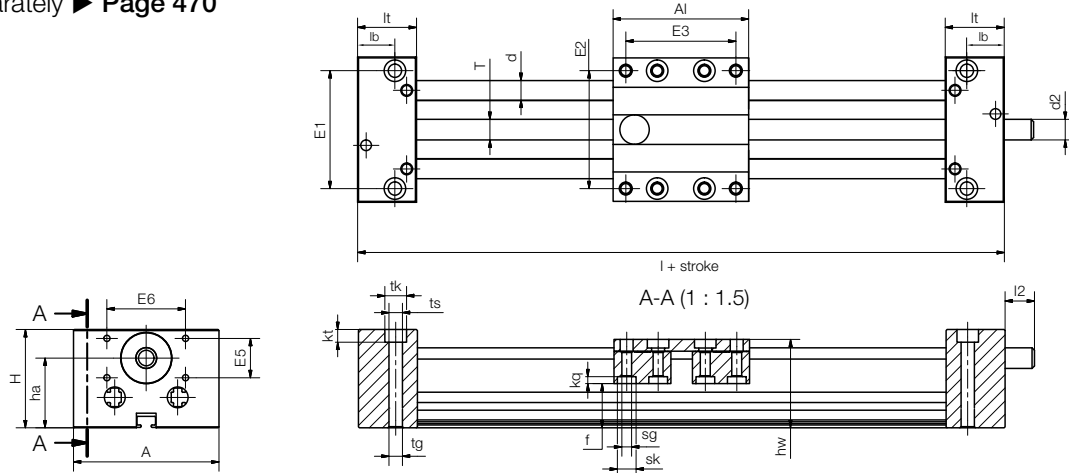

Technical data

| Part No. | Max. stroke length [mm] | Weight [kg] | Additional (per 100mm) | Max. rotational speed [rpm] | Max. static load capacity axial [N] | Max. static load capacity radial [N] |
|----------|-------------------------|-------------|------------------------|-----------------------------|-------------------------------------|--------------------------------------|
| SAW-0630 | 300                     | 0.5         | 0.1                    | 1,000                       | 100                                 | 400                                  |
| SAW-0660 | 500                     | 0.9         | 0.1                    | 1,000                       | 100                                 | 400                                  |
| SAW-1040 | 500                     | 1.0         | 0.1                    | 1,500                       | 500                                 | 2,000                                |
| SAW-1080 | 750                     | 1.9         | 0.2                    | 1,500                       | 750                                 | 2,000                                |
| SAW-1660 | 750                     | 2.8         | 0.5                    | 1,500                       | 750                                 | 3,000                                |

Dimensions [mm]

| Part No. | A    | Al         | H  | E1    | E2    | E3        | E5 | E6 | I           | lc    | hw | f    | lt   | lb    |
|----------|------|------------|----|-------|-------|-----------|----|----|-------------|-------|----|------|------|-------|
|          | -0.3 | -0.3       |    | +0.15 | +0.15 | +0.15     |    |    |             |       |    |      |      |       |
| SAW-0630 | 54   | 60/100     | 32 | 40    | 45    | 51/91     | 11 | 23 | 112/152     | 92    | 30 | 13.5 | 26   | 10    |
| SAW-0660 | 85   | 100        | 38 | 71    | 76    | 91        | -  | -  | 156         | -     | 34 | 13.7 | 28   | -     |
| SAW-1040 | 74   | 69/100/150 | 50 | 60    | 60    | 56/87/137 | 20 | 40 | 129/160/210 | 91    | 45 | 22.5 | 30   | 19    |
| SAW-1080 | 108  | 100        | 58 | 94    | 94    | 87        | -  | -  | 163         | 131.5 | 49 | 22.5 | 31.5 | 15.75 |
| SAW-1660 | 104  | 150        | 77 | 84    | 86    | 132       | 20 | 40 | 220         | 175   | 72 | 38.5 | 35   | 22.5  |

| Part No. | tk | ts  | tg     | kt   | sk  | sg | kq  | d  | T       | l2 | d2                           | ha   |
|----------|----|-----|--------|------|-----|----|-----|----|---------|----|------------------------------|------|
|          |    |     |        | ±0.1 |     |    |     |    | ∅       |    |                              |      |
| SAW-0630 | 11 | 6.6 | -      | 20   | -   | M4 | 10  | □5 | Tr8x1.5 | 15 | Tr8x1.5                      | 21.5 |
| SAW-0660 | -  | -   | M8x12  | 20   | 7   | M4 | 2   | □6 | Tr10x2  | 15 | Tr10x2                       | 23.0 |
| SAW-1040 | 11 | 6.8 | M8x20  | 6.4  | 9.5 | M6 | 3.5 | 10 | Tr10x2  | 17 | Tr10x2 ∅6 h9 <sup>113)</sup> | 35.5 |
| SAW-1080 | 11 | 6.8 | M8x20  | 18   | 9.5 | M6 | 3.5 | 10 | Tr12x3  | 17 | Tr12x3 ∅8 h9 <sup>113)</sup> | 37.5 |
| SAW-1660 | 15 | 9.0 | M10x29 | 8.6  | 11  | M8 | 5.5 | 16 | Tr14x4  | 20 | Tr14x4 ∅8 h9 <sup>113)</sup> | 59.0 |

<sup>113)</sup> Lead screw end unmachined, also available with machined end

Reduced clearance with pretension in lead screw support and lead screw nut

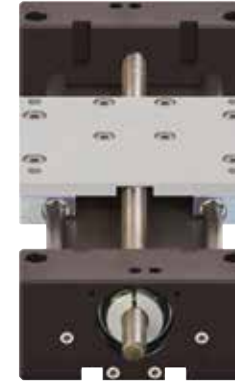

- Lubrication and maintenance-free
- Quiet, reduced backlash
- Trapezoidal or high helix threads
- 3 carriage lengths (100/150/200mm) with spring-loaded second lead screw nut
- Liners made from wear-resistant high-performance polymers
- For manual and electric adjustment even in multi-axis linear robots

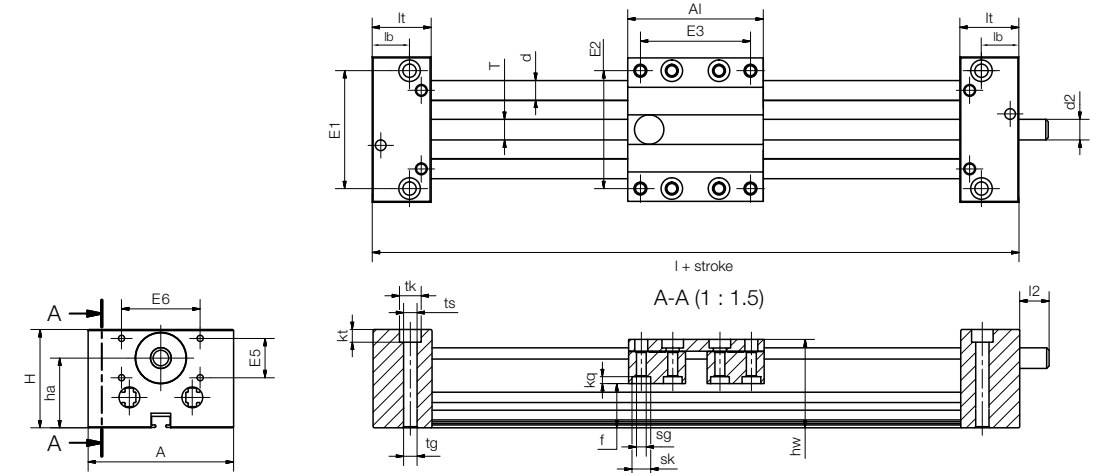

Technical data

| Part No.    | Max. stroke length [mm] | Weight [kg] | Additional (per 100mm) | Max. rotational speed [rpm] | Max. static load capacity axial [N] | Max. static load capacity radial [N] |
|-------------|-------------------------|-------------|------------------------|-----------------------------|-------------------------------------|--------------------------------------|
| SAW-1080-PL | 750                     | 1.9         | 0.2                    | 1,500                       | 750                                 | 2,000                                |

Dimensions [mm]

| Part No.    | A    | Al   | H  | E1    | E2    | E3    | E5 | E6 | I   | lc    | hw | f    | lt   | lb    |
|-------------|------|------|----|-------|-------|-------|----|----|-----|-------|----|------|------|-------|
|             | -0.3 | -0.3 |    | +0.15 | +0.15 | +0.15 |    |    |     |       |    |      |      |       |
| SAW-1080-PL | 108  | 100  | 58 | 94    | 94    | 87    | -  | -  | 163 | 131.5 | 49 | 22.5 | 31.5 | 15.75 |

| Part No.    | tk | ts  | tg    | kt   | sk  | sg | kq  | d  | T      | l2 | d2                           | ha   |
|-------------|----|-----|-------|------|-----|----|-----|----|--------|----|------------------------------|------|
|             |    |     |       | ±0.1 |     |    |     |    | ∅      |    |                              |      |
| SAW-1080-PL | 11 | 6.8 | M8x20 | 18   | 9.5 | M6 | 3.5 | 10 | Tr12x3 | 17 | Tr12x3 ∅8 h9 <sup>113)</sup> | 37.5 |

<sup>113)</sup> Lead screw end unmachined, also available with machined end



Direct drive in short design



- Smaller installation space and more stroke
- Compact short design due to the use of drylin® lead screw motors
- Optimised ratio of useful length to total length (compared to the SAW series, up to 70mm)
- Improved operating characteristics
- Space-saving and lightweight

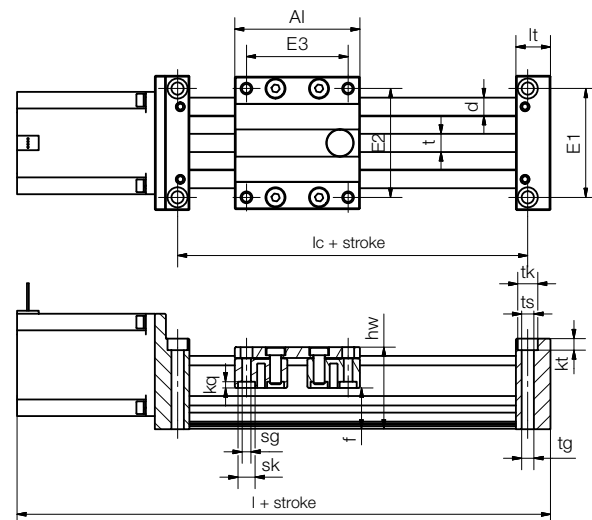
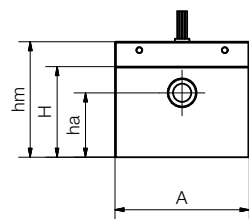

Technical data

| Part No.  | Max. stroke length<br>[mm] | Weight<br>[kg] | Additional<br>(per 100mm) | Max. rotational speed<br>[rpm] | Max. static load capacity |            |
|-----------|----------------------------|----------------|---------------------------|--------------------------------|---------------------------|------------|
|           |                            |                |                           |                                | axial [N]                 | radial [N] |
| SAWC-0630 | 300                        | 0.5            | 0.1                       | 1,000                          | 100                       | 200        |
| SAWC-1040 | 500                        | 1.0            | 0.1                       | 1,500                          | 500                       | 2,000      |

Dimensions [mm]

| Part No.  | A    | AI         | H    | E1    | E2    | E3    | l   | lc | hw | f    | lt | lb  |
|-----------|------|------------|------|-------|-------|-------|-----|----|----|------|----|-----|
|           | -0.3 | -0.3       |      | +0.15 | +0.15 | +0.15 |     |    |    |      |    |     |
| SAWC-0630 | 54   | 60/100     | 42.5 | 40    | 45    | 51    | 139 | 75 | 30 | 13.5 | 15 | 7.5 |
| SAWC-1040 | 74   | 69/100/150 | 50.0 | 60    | 60    | 56    | 183 | 82 | 45 | 22.5 | 19 | 9.5 |

| Part No.  | tk | ts  | tg    | kt   | sk  | sg | kq  | d  | T                                | ha   |
|-----------|----|-----|-------|------|-----|----|-----|----|----------------------------------|------|
|           |    |     |       | ±0.1 |     |    |     |    | Ø                                |      |
| SAWC-0630 | 8  | 4.2 | M5x12 | 20   | 7   | M4 | 2   | 5  | Tr08x1.5<br>Ds08x15              | 21.5 |
| SAWC-1040 | 11 | 6.8 | M6x20 | 6.4  | 9.5 | M6 | 3.5 | 10 | Tr10x2 <sup>92)</sup><br>Ds10x12 | 35.5 |

<sup>92)</sup> Lead screw end unmachined

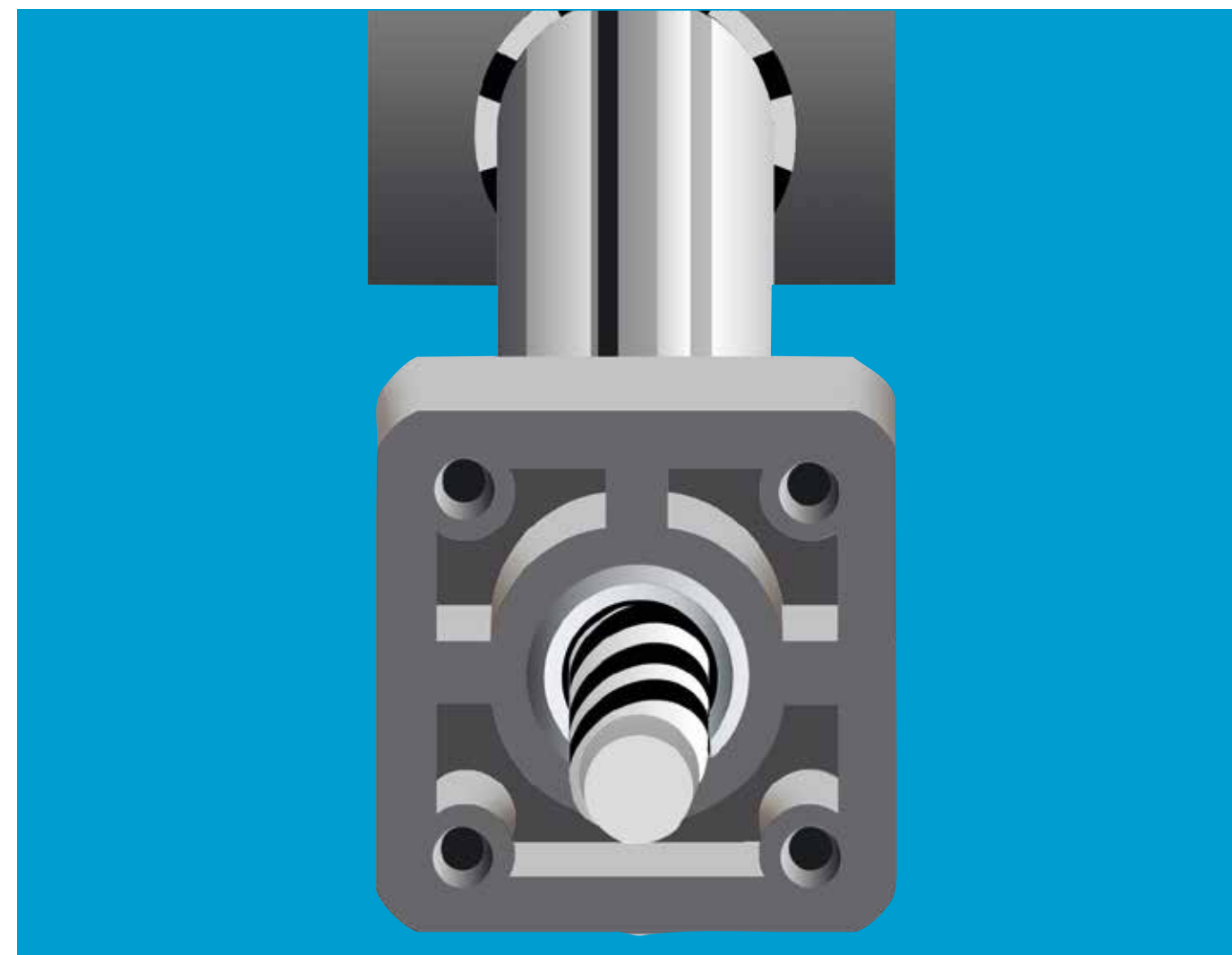

## drylin® general drive technology - SET linear modules

Lubrication-free single-tube adjustment

Drive: trapezoidal thread

Simple, smooth design

Lightweight due to aluminium and polymer

Temperature resistance up to +50°C



Single-tube adjustment

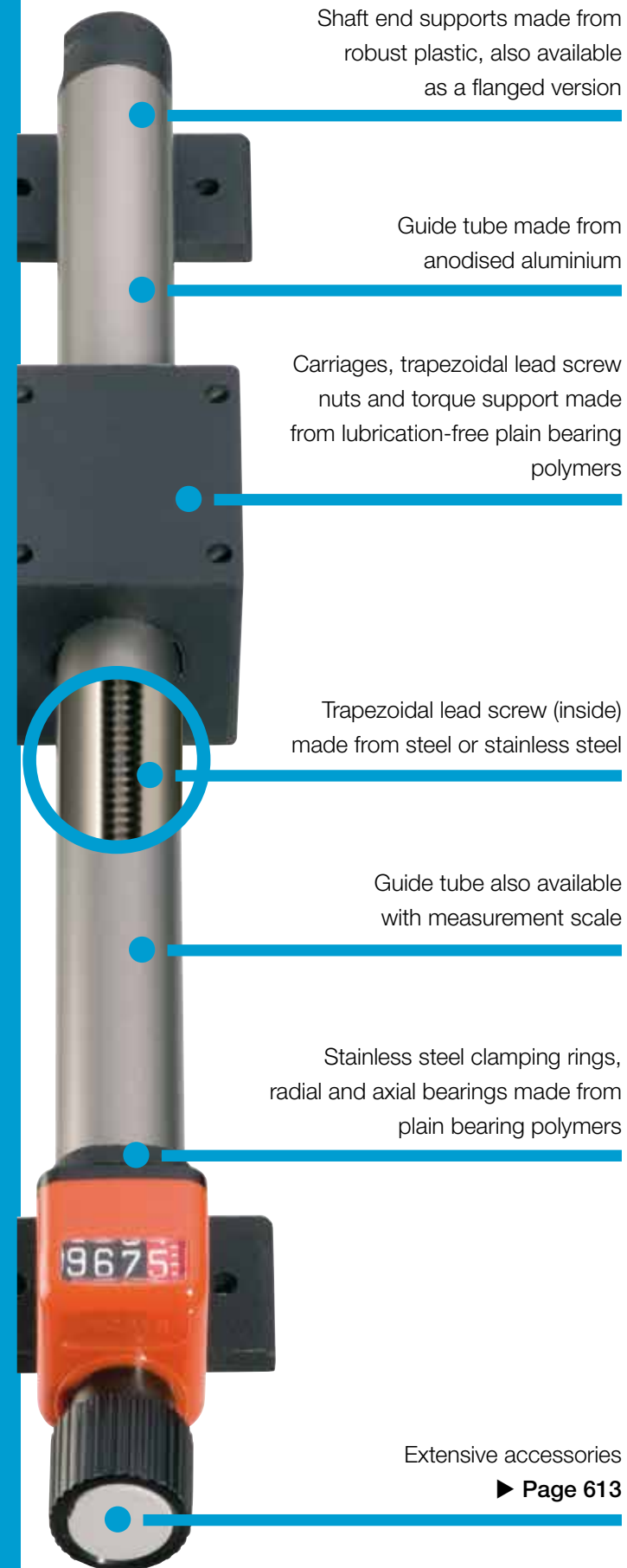

Shaft end supports made from robust plastic, also available as a flanged version

Guide tube made from anodised aluminium

Carriages, trapezoidal lead screw nuts and torque support made from lubrication-free plain bearing polymers

Trapezoidal lead screw (inside) made from steel or stainless steel

Guide tube also available with measurement scale

Stainless steel clamping rings, radial and axial bearings made from plain bearing polymers

Extensive accessories  
▶ Page 613

## Lubrication-free linear unit "easytube"

The linear unit for easy adjustment functions is characterised by a simple but effective and solid design. A complete system is built up from few components. The outer anodised aluminium tube guides the carriage/s and at the same time protects the trapezoidal lead screw and lead screw nut from external influences. Carriage, torque support and trapezoidal lead screw nut are in one component and are made from a special plain bearing high-performance polymer. This guarantees freedom from lubrication with simultaneously low coefficient of friction and optimal wear rates. The iglidur® bearing materials are also used in the thrust bearings of the lead screw.

- Protected lead screw
- Effective design
- Available with measurement scale without lead screw
- Flanged version for axial mounting in surfaces and profiles

### Typical application areas

- Sensor and camera positioning
- Format adjustment

 **Available in 3-8 days**  
Detailed information about delivery time online.

 **Price breaks online**  
No minimum order value. No minimum order quantity

 **Carriage lengths: 30-55mm**  
**Stroke lengths: up to 850mm**

 **Product finder**  
▶ [www.igus.eu/set-productfinder](http://www.igus.eu/set-productfinder)

Efficient design with protected lead screw and variable mounting



### easytube single tube linear unit

- For light format adjustments
  - Protected lead screw, torque-resistant
  - Drive: trapezoidal or high-helix lead screw
- ▶ Page 562



### easytube with double flange

- For axial mounting
  - Simple, smooth design
- ▶ Page 563



### easytube with single flange

- For horizontal and vertical adjustments
  - Single aluminium flange
  - Space-saving structure
- ▶ Page 564



### easytube with measurement scale

- With lasered, wash-proof scale
  - Carriage with clamp
  - Available with/without lead screw
- ▶ Page 565

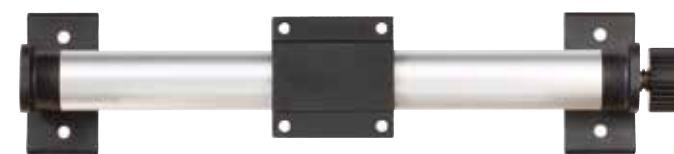

### easytube "light"

- Lightweight linear carriage
  - Compact structure
  - Also available as flanged version
- ▶ Page 566



### Accessories for linear modules

- Position indicator, hand wheels, lead screw clamps, angular drives and more
- ▶ From page 613

Order key

Order example

**SET-25-AWM**

|          |           |                |
|----------|-----------|----------------|
| easytube | Dimension | Shaft material |
|----------|-----------|----------------|

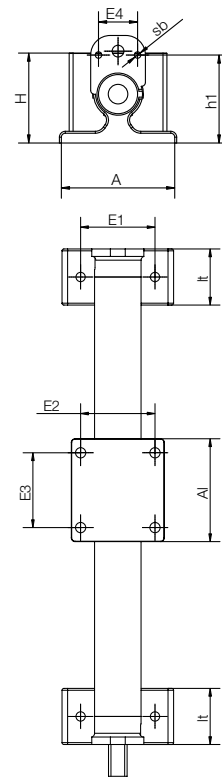
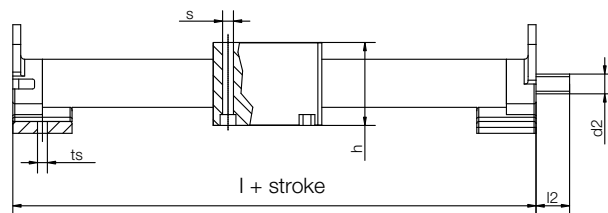

- For simple adjustments
- With protected lead screw
- Corrosion-free with stainless steel lead screw
- Lightweight due to aluminium and polymer
- Temperature-resistant up to +60°C
- Accessories available ► **Page 613**

Technical data

| Part No.   | Max. stroke length | Aluminium shaft                              |                        |  | Max. static load capacity |        |
|------------|--------------------|--|------------------------|--|---------------------------|--------|
|            |                    | Weight shaft end supports and guide carriage | additional (per 100mm) |  | axial                     | radial |
|            | [mm]               | [kg]   | [kg]                   |  | [N]                       | [N]    |
| SET-12-AWM | 200                | 0.05   | 0.03                   |  | 10                        | 20     |
| SET-25-AWM | 750                | 0.15   | 0.12                   |  | 150                       | 300    |
| SET-30-AWM | 850                | 0.20   | 0.21                   |  | 200                       | 400    |

Dimensions [mm]

| Part No.   | A  | A1 | H    | E1 | E2 | E3 | E4 | l   | h  | h1 | lt | ts  | Øs  | sb | l2 | d2 <sup>92)</sup> |
|------------|----|----|------|----|----|----|----|-----|----|----|----|-----|-----|----|----|-------------------|
| SET-12-AWM | 30 | 30 | 23.5 | 20 | 20 | 20 | -  | 60  | 22 | -  | 15 | 3.3 | 4.2 | -  | 10 | M4                |
| SET-25-AWM | 60 | 55 | 44   | 40 | 40 | 40 | 20 | 115 | 39 | 45 | 30 | 5.2 | 5.2 | M4 | 17 | Tr10x2            |
| SET-30-AWM | 80 | 55 | 49   | 60 | 40 | 40 | 20 | 125 | 39 | 50 | 35 | 6.5 | 5.2 | M4 | 20 | Tr12x3            |

<sup>92)</sup> Lead screw end unmachined

Order key

Order example

**SET-25-AWM-F**

|          |           |                |             |
|----------|-----------|----------------|-------------|
| easytube | Dimension | Shaft material | With flange |
|----------|-----------|----------------|-------------|

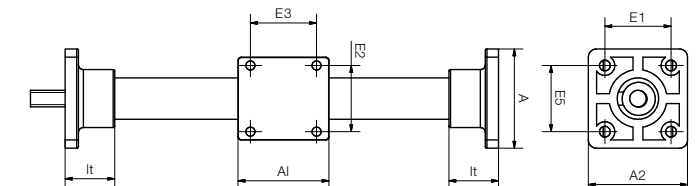
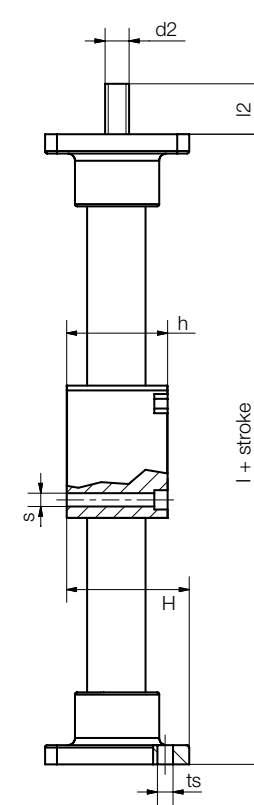

- Flanged version for axial mounting
- Simple, smooth design
- Accessories available ► **Page 613**

Technical data

| Part No.     | Max. stroke length | Aluminium shaft                              |                        |  | Max. static load capacity |        |
|--------------|--------------------|--|------------------------|--|---------------------------|--------|
|              |                    | Weight shaft end supports and guide carriage | additional (per 100mm) |  | axial                     | radial |
|              | [mm]               | [kg]   | [kg]                   |  | [N]                       | [N]    |
| SET-25-AWM-F | 750                | 0.15   | 0.12                   |  | 150                       | 300    |
| SET-30-AWM-F | 850                | 0.20   | 0.21                   |  | 200                       | 400    |

Dimensions [mm]

| Part No.     | A1 | A  | A2 | H  | E1 | E2 | E3 | E5 | l   | h  | lt | ts  | Øs  | l2 | d2 <sup>92)</sup> |
|--------------|----|----|----|----|----|----|----|----|-----|----|----|-----|-----|----|-------------------|
| SET-25-AWM-F | 55 | 60 | 60 | 49 | 40 | 40 | 40 | 40 | 115 | 39 | 30 | 5.2 | 5.2 | 27 | Tr10x2            |
| SET-30-AWM-F | 55 | 60 | 80 | 59 | 60 | 40 | 40 | 40 | 125 | 39 | 35 | 6.5 | 5.2 | 30 | Tr12x3            |

<sup>92)</sup> Lead screw end unmachined





Order example

SETB-25-AWM

- easytube
- Dimension
- Shaft material

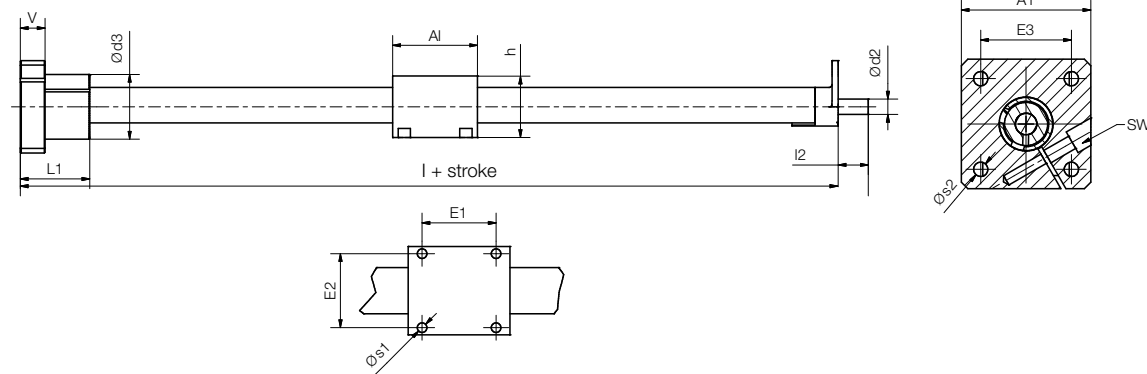

- Horizontal and vertical installation at one end
- Ideal for the positioning of sensors and cameras in format adjustments
- Easy assembly
- Flexible installation
- Space-saving
- Protected lead screw

Technical data

| Part No.    | Max. stroke length<br>[mm] | Max. static load capacity |                               |
|-------------|----------------------------|---------------------------|-------------------------------|
|             |                            | axial<br>[N]              | radial <sup>128)</sup><br>[N] |
| SETB-25-AWM | 300                        | 150                       | 12.5                          |

Dimensions [mm]

| Part No.    | A1 | A1 | h  | E1 | E2 | E3 | V  | L1 | I2 | d2 <sup>92)</sup> | d3 | l   | s1  | s2  | SW |
|-------------|----|----|----|----|----|----|----|----|----|-------------------|----|-----|-----|-----|----|
| SETB-25-AWM | 60 | 55 | 39 | 40 | 40 | 42 | 16 | 45 | 17 | Tr10x2            | 42 | 130 | 5.2 | 6.6 | 5  |

<sup>92)</sup> Lead screw end unmachined

More dimensions upon request

<sup>128)</sup> The supporting torque at the clamping flange must not exceed 10Nm

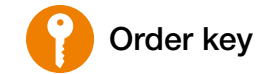

Order example

SET M-25-AWM-200-SC

- easytube
- Manual
- Dimension
- Shaft material
- Stroke length
- Scaling



Options:

- Manual
- without lead screw (optional)

- Lasered, wash-proof scale
- Corrosion-resistant
- Multi-position clamp
- Available with/without lead screw
- 3 stroke lengths available from stock

Technical data

|                                     |      |     |
|-------------------------------------|------|-----|
| F radial                            | [N]  | 300 |
| Max. extension at maximum load      | [mm] | 66  |
| Max. extension at 100N nominal load | [mm] | 200 |
| Max. drive force without load       | [N]  | 10  |
| Max. holding force                  | [N]  | 100 |
| Max. stroke length                  | [mm] | 600 |

Dimensions [mm]

| Part No. measurement scale<br>without lead screw | Part No. measurement scale<br>with trapezoidal lead screw 10x2 | Stroke length<br>[mm] |
|--|--|-----------------------|
| SETM-25-AWM-200-SC                               | SET-25-AWM-200-SC  | 200                   |
| SETM-25-AWM-400-SC                               | SET-25-AWM-400-SC  | 400                   |
| SETM-25-AWM-600-SC                               | SET-25-AWM-600-SC  | 600                   |

More dimensions see SET ► Page 562



Order key

Order example

SETC-25-AWM

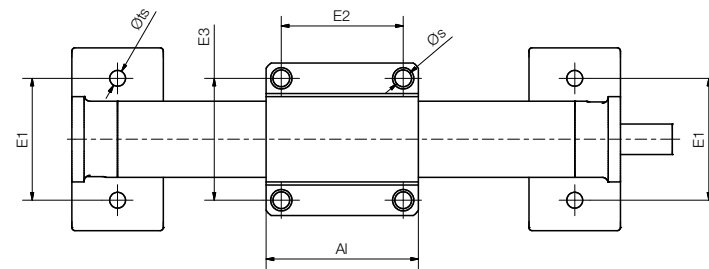
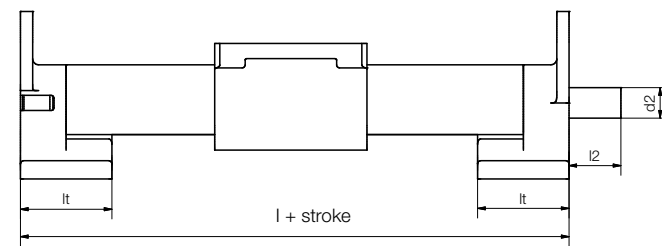
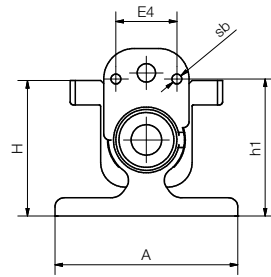

- Weight-optimised
- Cost-effective
- Simplified assembly
- Light, clean and quiet

Technical data

| Part No.    | Weight<br>[kg] | Max. stroke length<br>[mm] | Max. static load capacity |               |
|-------------|----------------|----------------------------|---------------------------|---------------|
|             |                |                            | axial<br>[N]              | radial<br>[N] |
| SETC-25-AWM | 0.15           | 750                        | 150                       | 300           |

Dimensions [mm]

| Part No.    | A  | Al | H  | E1 | E2 | E3 | E4 | I   | h1 | I1 | ts  | Øs  | sb | I2 | d2 <sup>92)</sup> |
|-------------|----|----|----|----|----|----|----|-----|----|----|-----|-----|----|----|-------------------|
| SETC-25-AWM | 60 | 55 | 44 | 40 | 40 | 40 | 20 | 115 | 45 | 30 | 5.2 | 5.2 | M4 | 17 | Tr10x2            |

<sup>92)</sup> Lead screw end unmachined

More dimensions upon request

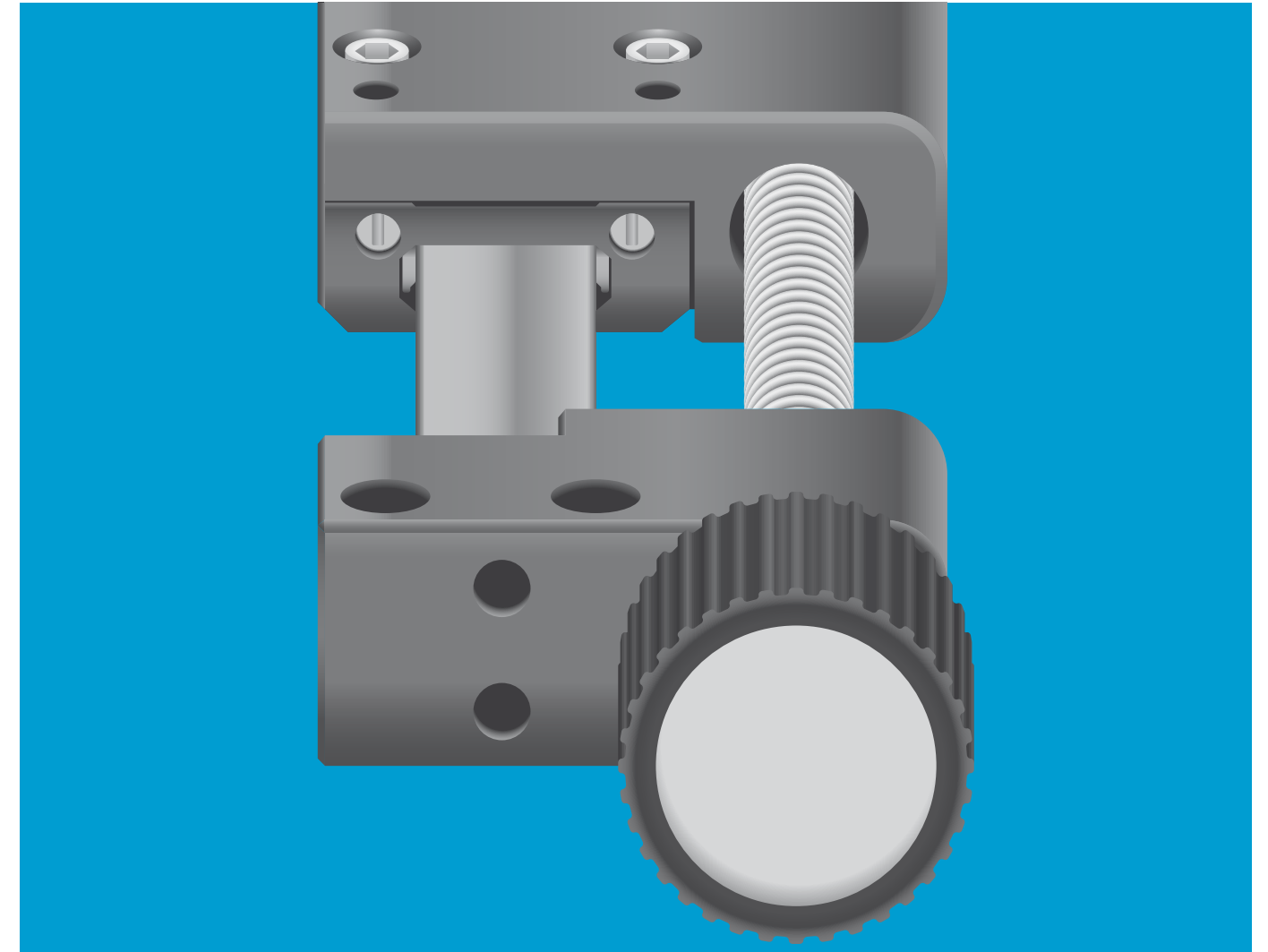

## drylin® general drive technology - SLT linear modules

Based on lubrication-free drylin® T  
miniature guide

Drive: Trapezoidal or high helix lead screw

Low-profile and compact design

Carriages with individual clearance adjustment

Variable lead screw options



Flat, lightweight and lubrication-free

## Lubrication-free linear modules - drylin® SLT

The low profile, the lateral lead screw arrangement and a striking design, are just some of the reasons why the drylin® SLT linear module was honoured with the 2014 IF Award. Technically, the system impresses with ball bearing mounted trapezoidal or high helix thread lead screws for motorised or manual operation. The basis of the SLT series is the drylin® T miniature guide in sizes 12 and 15.

- Low-profile structure through lateral lead screw arrangement
- Lubrication-free, corrosion-resistant, lightweight
- Variable pitch
- Adjustable drylin® T miniature carriage with individual clearance adjustment
- Lead screw arrangement can be selected either left or right

### Typical application areas

- Format adjustments
- Laboratory and medical technology
- Optical equipment

 **Available in 3-8 days**  
Detailed information about delivery time online.

 **Max. +60°C**  
**min. -40°C**

 **Stroke lengths 300-600mm**  
More dimensions upon request.

 **Product finder**  
► [www.igus.eu/slt-productfinder](http://www.igus.eu/slt-productfinder)

 **In accordance with EC Directive 2011/65 EU (RoHS 2) Restriction (of the use of certain) hazardous substances**

Shaft end supports/ carriages made of anodised aluminium

Ball bearing supported lead screws

Lead screw arrangement left or right of the carriage

Self-locking trapezoidal thread or fast adjustment with high helix thread

drylin® T miniature carriage with individual clearance adjustment

Lead screws of steel or stainless steel

Hard-anodised drylin® T miniature guide rail

Hand wheel, position indicator and lead screw clamp as accessories  
► [Page 613](#)



Can be configured as ready-to-connect linear axis with motor and initiators

► [www.igus.eu/drylin-automation](http://www.igus.eu/drylin-automation)



2013

With ball bearing supported lead screw

 **Order key**

Order example

**SLT-BB-0412- E R-S 0015 R G-□**

|      |        |                   |                         |                      |            |       |        |                |                     |
|------|--------|-------------------|-------------------------|----------------------|------------|-------|--------|----------------|---------------------|
| Type | Design | Installation size | Adjustable carriage TWE | Lead screw alignment | Lead screw | Pitch | Thread | Lead screw end | Stroke length in mm |
|------|--------|-------------------|-------------------------|----------------------|------------|-------|--------|----------------|---------------------|

Options:

|                             |                    |                       |
|-----------------------------|--------------------|-----------------------|
| <b>Design</b>               | <b>Lead screw</b>  | <b>Lead screw end</b> |
| BB: With ball bearings      | S: Steel           | G: Threaded end       |
| <b>Lead screw alignment</b> | ES Stainless steel | <b>Thread</b>         |
| R: Right (standard)         |                    | R: Right              |
| L: Left                     |                    |                       |

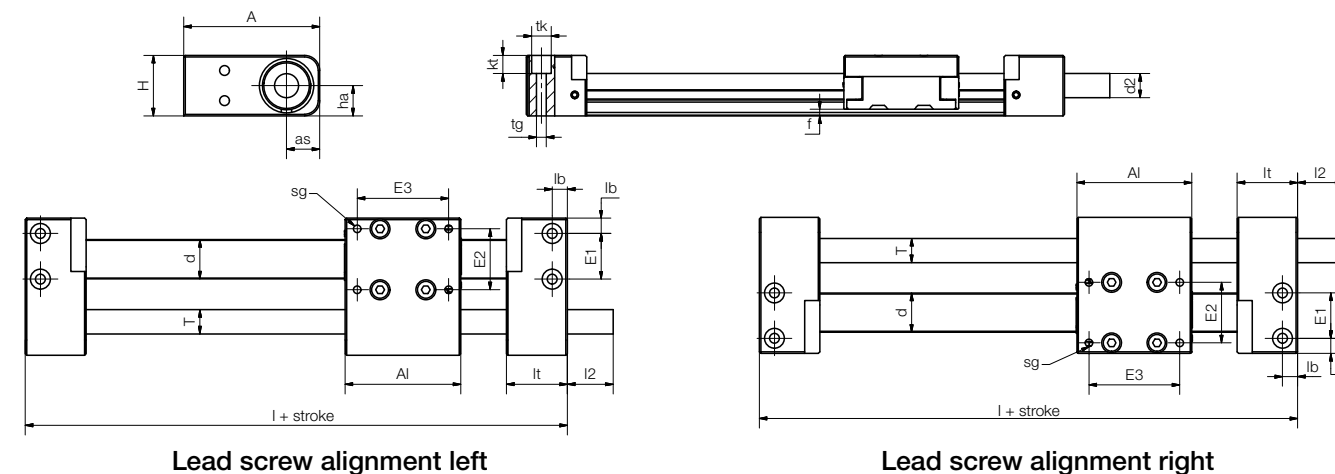

### Technical data and dimensions [mm]

| Part No.    | Pitch   | Max. stroke length | Weight additional (per 100mm) |      | Max. static load capacity |            | Max. speed [1/min] | Max. speed [m/min] |
|-------------|---------|--------------------|-------------------------------|------|---------------------------|------------|--------------------|--------------------|
|             |         |                    | [kg]                          | [kg] | axial [N]                 | radial [N] |                    |                    |
| SLT-BB-0412 | Ds8x15  | 300                | 0.15                          | 0.06 | 25                        | 100        | 1,000              | 15                 |
| SLT-BB-0415 | Ds12x25 | 600                | 0.40                          | 0.12 | 100                       | 400        | 1,000              | 25                 |

| Part No.    | A  | Al | H  | E1 | E2 | E3 | l  | l2 | d2 | ha | sg    | tk  | kt  | tg    | f   | lb  | lt | d  | T        | as |
|-------------|----|----|----|----|----|----|----|----|----|----|-------|-----|-----|-------|-----|-----|----|----|----------|----|
| SLT-BB-0412 | 45 | 38 | 20 | 15 | 20 | 30 | 78 | 15 | -  | 10 | M3-7  | 6.5 | 6   | M4    | 2.2 | 5   | 20 | 13 | Tr08x1.5 | 11 |
| SLT-BB-0415 | 58 | 45 | 30 | 19 | 25 | 35 | 89 | 17 | 12 | 15 | M3-13 | 8   | 4.5 | M5-15 | 2.8 | 6.5 | 22 | 17 | Tr12x3   | 16 |

Also see econ chapter ► [Page 605](#)



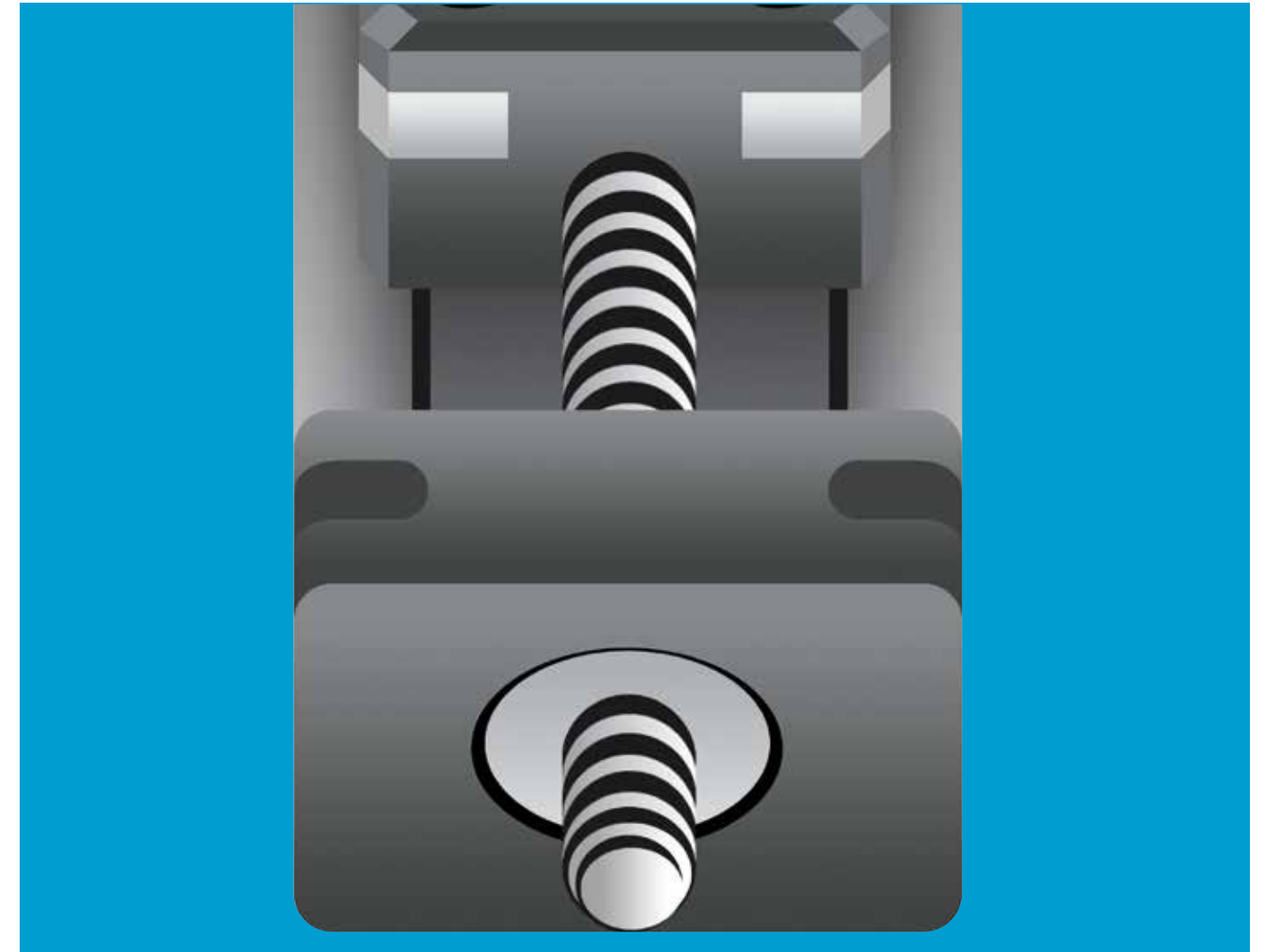
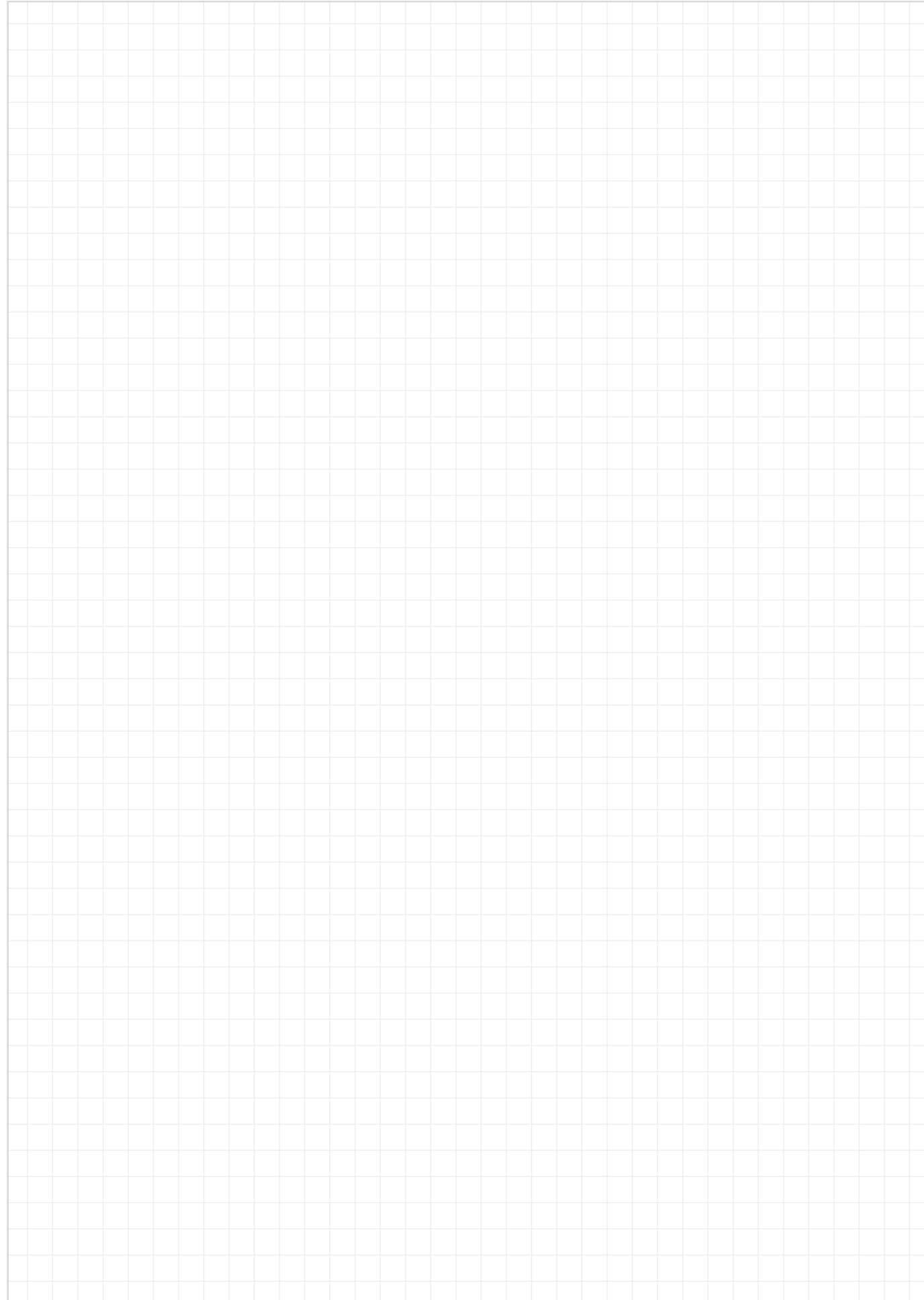

## drylin<sup>®</sup> general drive technology - SLN/SLNV linear modules

Based on lubrication-free drylin<sup>®</sup> N low-profile  
linear guide

Drive: Trapezoidal or high helix lead screw

Compact design

Clearance adjustment on carriage

Precise with pre-load



Compact, precise and lubrication-free

## Lubrication-free miniature linear modules - drylin® SLN

drylin® SLN linear axes is a compact solution. The axis measures 28 x 22mm and can be configured with stroke lengths of up to 250mm. Thanks to the lubrication-free plastic sliders, it is quiet and very light. The axis is based on the tried-and-tested drylin® N system, size 27. It is available both mounted on plain bearings or on ball bearings in the shaft end supports. The drylin® SLN linear axis can be adjusted manually using the hand wheel or combined with the drylin® E stepper and DC motors.

- Ultra-compact design
- 3 carriage types (basic/adjustable/pre-load)
- Lubrication-free drylin® low-profile linear guide
- Modular design

### Typical application areas

- Sensor technology
- Inspection technology
- Laboratory technology
- Medical technology

 **Available in 3-8 days**  
Detailed information about delivery time online.

 **Price breaks online**  
No minimum order value. No minimum order quantity

 **Carriage length: 35mm**  
**Stroke lengths: up to 250mm**

 **Product finder**  
▶ [www.igus.eu/sln-productfinder](http://www.igus.eu/sln-productfinder)

Shaft end supports made from corrosion-resistant, robust plastic

Lead screw mounted with plain or ball bearings

Cost-effective, robust plastic carriages (basic series 03)

Carriage with manual height clearance adjustment (standard series 04)

Metal thread inserts

Minimal backlash with pre-load (pre-load series 05)

Rail made from anodised aluminium

Lead screws made from stainless steel with pitch M5 (5x0.8mm) or high helix thread (5x5, 6x12.7)

Hand wheel available ▶ [Page 621](#)

Configurable with motor as a ready-to-install linear drive



Miniature linear module, pre-load version



- Based on maintenance-free drylin® N low-profile linear guides size 27
- BB version (ball bearing) for minimal backlash run
- Manual and motorised operation possible
- Linear carriage with individual height clearance adjustment and pre-load (optional)
- Accessories available  
▶ [Page 613](#)
- Also see econ chapter  
▶ [Page 610](#)
- Available with motor

 **Order key**

Order example

**SLN- 27 - 1 4 - 0008**

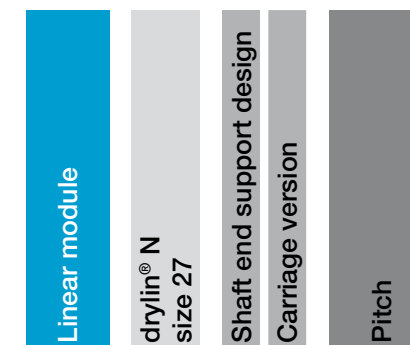

Options:

Shaft end support design Pitch

0: Plain bearing 0008: M5x0.8

1: Ball bearing 0050: Sg5x5

Carriage version 0008: Ds6.35x2.54

4: Standard, adjustable 0127: Sg6.35x12.7

5: Standard, pre-load 0254: Ds6.35x25,4

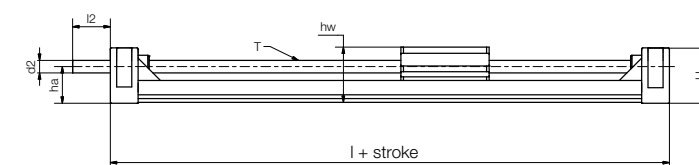
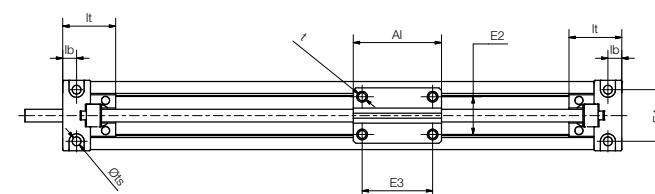
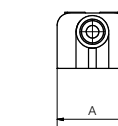

### Technical data

| Part No.  | Max. stroke length <sup>101)</sup> | Weight [kg] | addit. [kg] (per 100mm) | Max. static load capacity |            | Max. speed [rpm] | Max. drive torque [Nm] |
|-----------|------------------------------------|-------------|-------------------------|---------------------------|------------|------------------|------------------------|
|           | [mm]                               |             |                         | axial [N]                 | radial [N] |                  |                        |
| SLN-27-04 | 250                                | 0.06        | 0.04                    | 10                        | 40         | 100              | 0.1                    |
| SLN-27-05 | 250                                | 0.06        | 0.04                    | 10                        | 40         | 100              | 0.1                    |
| SLN-27-14 | 250                                | 0.06        | 0.04                    | 10                        | 40         | 300              | 0.1                    |
| SLN-27-15 | 250                                | 0.06        | 0.04                    | 10                        | 40         | 300              | 0.1                    |

### Dimensions [mm]

| Part No.  | A    | A1   | H    | E1    | E2    | E3    | E11 <sup>102)</sup> | I  | hw   | It   | lb | ts  | d2 <sup>98)</sup>   | I2 | ha   |
|-----------|------|------|------|-------|-------|-------|---------------------|----|------|------|----|-----|---------------------|----|------|
|           | ±0.2 | -0.1 | ±0.2 | ±0.15 | ±0.15 | ±0.15 |                     |    | ±0.2 | ±0.2 |    |     | ∅                   |    |      |
| SLN-27-04 | 28   | 35   | 22   | 20.5  | 15    | 28    | 15                  | 77 | 22.5 | 21   | 5  | 3.5 | 5 (4 h7)            | 15 | 14.5 |
| SLN-27-05 | 28   | 35   | 22   | 20.5  | 15    | 28    | 15                  | 77 | 22.5 | 21   | 5  | 3.5 | 5 (4 h7)            | 15 | 14.5 |
| SLN-27-14 | 28   | 35   | 22   | 20.5  | 15    | 28    | 15                  | 77 | 22.5 | 21   | 5  | 3.5 | ∅4h9 <sup>98)</sup> | 15 | 14.5 |
| SLN-27-15 | 28   | 35   | 22   | 20.5  | 15    | 28    | 15                  | 77 | 22.5 | 21   | 5  | 3.5 | ∅4h9 <sup>98)</sup> | 15 | 14.5 |

<sup>101)</sup> Fixed stroke lengths for SLN option with ball bearings: 100/150/200/250mm

<sup>102)</sup> The dimension E11 can only be found in conjunction with the igus® motor connection <sup>98)</sup>Thread/ remaining thread visible





- SLNV linear module for the smallest installation spaces
- For stroke lengths up to 250mm
- High precision due to stop motion preload prism slide
- Clearance reduction in z and y directions due to pre-load
- Lead screw with plain or ball bearing
- Self-locking with trapezoidal thread Tr6x2
- Fast and efficient with pre-load
- Feed rate up to 25.4mm per rotation

**Typical application areas:**

- Medical technology
- Dental equipment
- Research and development
- Measuring technology

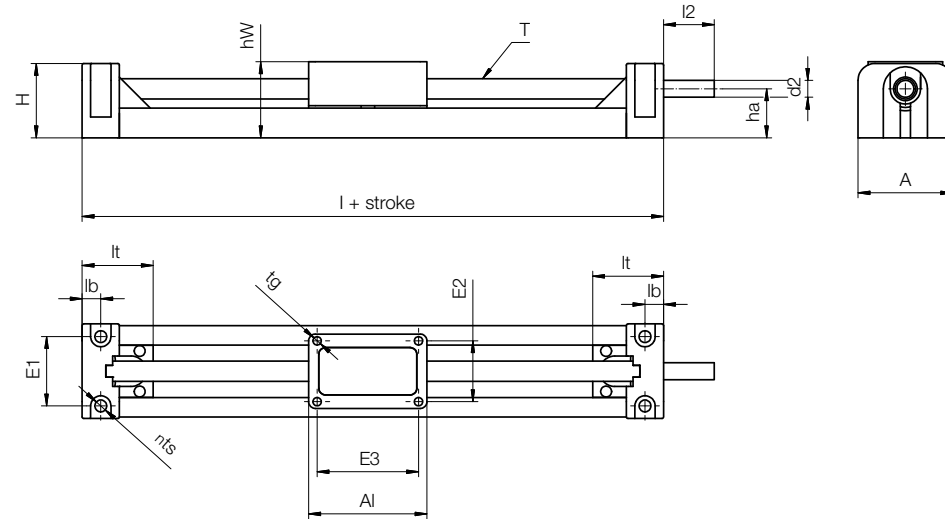

**Technical data**

| Part No.     | Max. stroke length<br>[mm] | Weight                    |     | Max. static load capacity |        | Maximum rotational speed<br>[rpm] | Maximum drive torque<br>[Nm] |
|--------------|----------------------------|---------------------------|-----|---------------------------|--------|-----------------------------------|------------------------------|
|              |                            | addit. (per 100mm)<br>[g] | [g] | axial                     | radial |                                   |                              |
| SLNV-27-0025 | 250                        | 80                        | 56  | 10                        | 40     | 300                               | 0.1                          |
| SLNV-27-0051 | 250                        | 80                        | 56  | 10                        | 40     | 300                               | 0.1                          |
| SLNV-27-0127 | 250                        | 80                        | 56  | 10                        | 40     | 300                               | 0.1                          |
| SLNV-27-0254 | 250                        | 80                        | 56  | 10                        | 40     | 300                               | 0.1                          |

**Dimensions [mm]**

| Part No.     | A    | A1   | H    | E1    | E2    | E3    | I  | hw   | lt   | lb  | ts  | tg        | d2 <sup>98)</sup> | l2 | ha   |
|--------------|------|------|------|-------|-------|-------|----|------|------|-----|-----|-----------|-------------------|----|------|
|              | ±0.2 | -0.1 | ±0.2 | ±0.15 | ±0.15 | ±0.15 |    | ±0.3 | ±0.2 |     |     |           | 4 h7              |    |      |
| SLNV-27-0025 | 28   | 35   | 22   | 20.5  | 18    | 30    | 77 | 22.5 | 21   | 5.5 | 3.5 | 6.35x2.54 | 5                 | 15 | 14.5 |
| SLNV-27-0051 | 28   | 35   | 22   | 20.5  | 18    | 30    | 77 | 22.5 | 21   | 5.5 | 3.5 | 6.35x5.08 | 5                 | 15 | 14.5 |
| SLNV-27-0127 | 28   | 35   | 22   | 20.5  | 18    | 30    | 77 | 22.5 | 21   | 5.5 | 3.5 | 6.35x12.7 | 5                 | 15 | 14.5 |
| SLNV-27-0254 | 28   | 35   | 22   | 20.5  | 18    | 30    | 77 | 22.5 | 21   | 5.5 | 3.5 | 6.35x25.4 | 5                 | 15 | 14.5 |

<sup>98)</sup> Thread/remaining thread visible

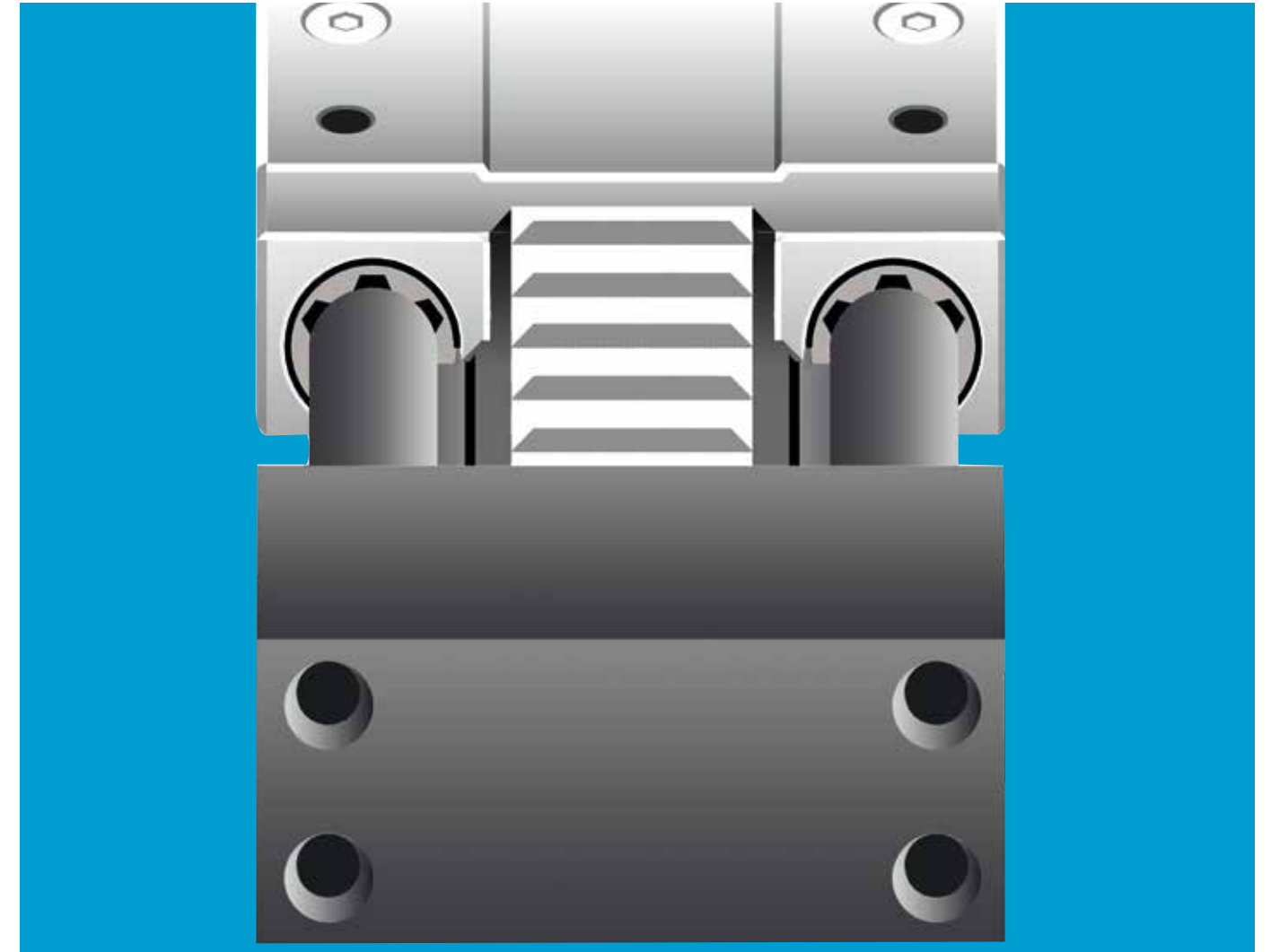

## drylin® general drive technology - toothed belt axes

Lubrication-free linear modules based on drylin® W guides

Drive: Toothed belt

For fast positioning

End supports with deep groove ball bearings

As single axis or for multi-axis linear robots





Fast and powerful

Shaft end supports made from robust plastic with integrated deep groove ball bearing

Deflection axis, square, with tooth rim made of dry-tech® high-performance polymer or single-section stainless steel shaft with drive pulley

The complete carriage consists of four lubrication-free drylin® W individual bearing housings and anodised aluminium assembly plates

Carriages available in 3 different lengths

High-profile, torsion-resistant drylin® W double shaft profile, made from hard anodised aluminium

Abrasion-resistant PU toothed belts with steel reinforcement or Neoprene with fibreglass

Profile grooves for mounting via the slot nuts or the clamping elements

Left or right-hand drive pin, also available as dual-sided pin for linear robot structures

Configurable with motor as a ready-to-install linear drive

## Lubrication-free toothed belt axes - drylin® ZLW

The drylin® toothed belt axes in the ZLW series are suitable for many different positioning and adjustment tasks. The lubrication-free drylin® W profile guide acts as a linear guide and a toothed belt acts as a drive. The stroke is freely selectable. Thanks to the lightweight design using plastic and aluminium, drylin® ZLW toothed belt axes have a low mass inertia, making them highly efficient. Whether as an individual system or a linear robot structure, the ZLW series offers the ideal solution in both confined spaces and applications that require a high level of support. All drylin® ZLW toothed belt axes can be ordered ready for connection and configured with drylin® stepper and DC motors. It is also possible to integrate other motor components.

- Completely lubrication-free operation
- 3 types: econ/basic/standard
- Variable carriage lengths
- Many motor kits available

### Typical application areas

- Medical and laboratory technology
- Handling
- Positioning tasks (pick & place)
- Camera/sensor adjustment
- Machine construction

 **Available in 3-8 days**  
Detailed information about delivery time online.

 **Price breaks online**  
No minimum order value. No minimum order quantity

 **Carriage lengths: 60-250mm**  
**Carriage widths: 54-107mm**  
**Stroke length: up to 3,000mm**

 **Product finder**  
▶ [www.igus.eu/zlw-productfinder](http://www.igus.eu/zlw-productfinder)

Positioning with lubrication-free toothed belt drive



### ZLW econ series

- Cost-effective starter axis in 2 sizes
  - Lightweight
  - Carriage and deflection housing made of plastic
  - Anodised drylin® W aluminium profile section
- ▶ Page 586



### ZLW standard series

- Effective PU toothed belt with steel cables
  - Single-section deflection axis made of stainless steel (shaft and tooth rim)
  - Hard-anodised drylin® W aluminium profile
  - For installation sizes 0630/1040/1080/1660
- ▶ Page 586



### ZLW-OD reverse

- For quick reverse positioning
  - Fast right/left adjustment
  - Compact due to flat drylin® W double rails
  - With angle flange
- ▶ Page 592

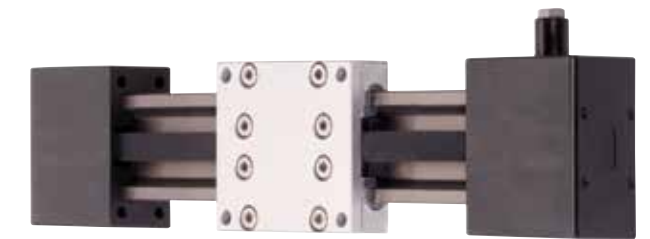
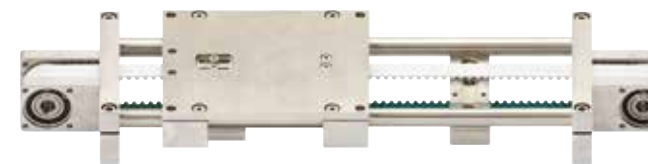

### ZLW basic series

- Cost-effective deflection axis consisting of stainless-steel square section and high-performance polymer
  - Neoprene toothed belts with fibre glass reinforcement
  - Hard-anodised drylin® W aluminium profile
  - For installation sizes 0630 and 1040
- ▶ Page 586



### ZLW specialists

- Deep-freeze LT version for applications down to -30°C
  - UW version for underwater use
  - SW version for splash water applications
  - For installation size 1040
- ▶ Page 586



### ZAW - cantilever axis

- Secure mounting of the drive unit
  - Traversing of profile section and load
  - Fixed end block and floating shaft end support
  - Size 1040 for max. stroke up to 1,000mm
- ▶ Page 599

### ZLW - open design in installation size 20

- Variable shaft span of 120/160/200mm
  - Effective deflection axis and toothed belt
  - Lightweight aluminium version available
  - Corrosion-resistant stainless steel version
- ▶ Page 588

### Motors and mounting accessories

▶ Page 613



# drylin® ZLW | Toothed belt axes | Technical data

| Toothed belt axis   | Version          | Shaft<br>Ø<br>[mm] | Weight                 |                      | Max. stroke length <sup>120)</sup><br>[mm] | Trans- mission<br>[mm/rev] | Tooth profile | Carriage length<br>[mm] |
|---------------------|------------------|--------------------|------------------------|----------------------|--|----------------------------|---------------|-------------------------|
|                     |                  |                    | without stroke<br>[kg] | 100mm stroke<br>[kg] |  |                            |               |                         |
| ZLN-40              | -                | 40                 | 0.24                   | 0.05                 | 750  | 60                         | T2.5          | 50                      |
| <b>ZLW-0630-...</b> |                  |                    |                        |                      |  |                            |               |                         |
| ...-02-E            | econ             | □6                 | 0.30                   | 0.08                 | 500  | 54                         | HTD 3M        | 60                      |
| ...-02-B            | Basic            | □6                 | 0.38                   | 0.08                 | 1,000                                      | 54                         | HTD 3M        | 60/100                  |
| ...-02-S            | Standard         | 8                  | 0.43                   | 0.08                 | 1,000                                      | 54                         | MTD3          | 60/100                  |
| ...-OD-B            | Reverse basic    | □6                 | 0.40                   | 0.1                  | 1,000                                      | 54                         | HTD 3M        | 60/100                  |
| ...-OD-S            | Reverse standard | 8                  | 0.45                   | 0.1                  | 1,000                                      | 54                         | HTD 3M        | 60/100                  |
| ZLW-0660-S-02-      | Standard         | 10                 | 0.88                   | 0.15                 | 1,000                                      | 54                         | HTD 3M        | 100/150/200             |
| <b>ZLW-1040-...</b> |                  |                    |                        |                      |  |                            |               |                         |
| ...-02-E            | econ             | 10                 | 0.70                   | 0.14                 | 1,000                                      | 66                         | RPP 3M        | 100/150/200             |
| ...-02-B            | Basic            | 10                 | 0.90                   | 0.14                 | 2,000                                      | 66                         | RPP 3M        | 100/150/200             |
| ...-02-S            | Standard         | 10                 | 1.00                   | 0.14                 | 2,000                                      | 70                         | AT5           | 100/150/200             |
| ...-02-LT           | Deep-freeze      | 10                 | 1.00                   | 0.14                 | 2,000                                      | 70                         | AT5           | 100/150/200             |
| ...-02-UW           | Underwater       | 10                 | 1.00                   | 0.14                 | 1,000                                      | 70                         | AT5           | 100/150/200             |
| ...-02-SW           | Splash water     | 10                 | 1.00                   | 0.14                 | 2,000                                      | 70                         | AT5           | 100/150/200             |
| ...-OD-B            | Reverse basic    | 10                 | 1.00                   | 0.17                 | 1,500                                      | 66                         | RPP 3M        | 100/150/200             |
| ...-OD-S            | Reverse standard | 10                 | 1.00                   | 0.17                 | 1,500                                      | 70                         | AT5           | 100/150/200             |
| <b>ZLW-1080-...</b> |                  |                    |                        |                      |  |                            |               |                         |
| ...-02-S            | Standard         | 10                 | 1.30                   | 0.21                 | 2,000                                      | 70                         | AT5           | 100/150/200             |
| ZLW-10120           | Standard         | 10                 | 2.03                   | 0.16                 | 2,000                                      | 75                         | 3M            | 150/200/250             |
| ZLW-10160           | Standard         | 10                 | 2,28                   | 0.17                 | 2,000                                      | 75                         | 3M            | 151/200/250             |
| ZLW-10200           | Standard         | 10                 | 2.54                   | 0.19                 | 2,000                                      | 75                         | 3M            | 152/200/250             |
| <b>ZLW-1660-...</b> |                  |                    |                        |                      |  |                            |               |                         |
| ...-02-S            | Standard         | 16                 | 4.00                   | 0.5                  | 3,000                                      | 120                        | AT5           | 100/150/200/250         |
| <b>ZLW-20...</b>    |                  |                    |                        |                      |  |                            |               |                         |
| ...120              | Standard         | 20                 | 5.36                   | 0.386                | 3,000                                      | 144                        | 20 RPP8       | 200/250/300             |
| ...120-HYD          | Hygienic design  | 20                 | 2.03                   | 0.16                 | 2,500                                      | 144                        | 8M            | 200                     |
| ...160              | Standard         | 20                 | 5.78                   | 0.426                | 3,000                                      | 144                        | 20 RPP8       | 200/250/300             |
| ...200              | Standard         | 20                 | 62                     | 0.466                | 3,000                                      | 144                        | 20 RPP8       | 200/250/300             |

<sup>120)</sup> When configuring your linear module, we ask that you note the igus® specifications for maximum stroke lengths. The performance and load specifications shown above for all drive units are based exclusively on stroke lengths within the recommended values. Exceeding these can result in undesirable effects to the function such as increased wear and noise. Belt or lead screw contact cannot be excluded, and the rated performance and load specifications may not be attainable.

## Tightening torque for drylin® metallic screws

| Metric thread (Da) | Tightening torque | Recommended tightening torque |
|--------------------|-------------------|-------------------------------|
|                    | [Nm]              | [Nm]                          |
| M3                 | 0.5 - 1.1         | 0.7                           |
| M4                 | 1.0 - 2.8         | 1.5                           |
| M5                 | 2.0 - 5.5         | 3.0                           |
| M6                 | 4.0 - 10.0        | 6.0                           |
| M8                 | 8.0 - 23.0        | 15.0                          |
| M10                | 22.0 - 46.0       | 30.0                          |

Please be aware of the minimal screw-in depth for aluminium and zinc die-casting parts: 1.5xDa

| Max. radial load<br>[N] | Toothed belt material         | Toothed belt width<br>[mm] | Toothed belt tension<br>[N] | Guide bearing                           | Max. speed | Max. position accuracy | Idle torque | Max. drive torque |
|-------------------------|-------------------------------|----------------------------|-----------------------------|---|------------|------------------------|-------------|-------------------|
|                         |                               |                            |                             |   | [m/s]      | [mm]                   | [Nm]        | [Nm]              |
| 45                      | PU with steel                 | 6                          | 30                          | Deep groove ball bearings               | 2.0        | ± 0.30                 | 0.15        | 0.4               |
| 30                      | Neoprene with GF              | 9                          | 20                          | Deep groove ball bearings               | 1.0        | ± 0.40                 | 0.10        | 0.30              |
| 100                     | Neoprene with GF              | 9                          | 75                          | Deep groove ball bearings               | 2.0        | ± 0.35                 | 0.10        | 0.75              |
| 150                     | PU with steel                 | 9                          | 100                         | Deep groove ball bearings               | 2.0        | ± 0.30                 | 0.15        | 1.00              |
| 50                      | Neoprene with GF              | 9                          | 75                          | Deep groove ball bearings               | 1.0        | ± 0.35                 | 0.10        | 0.75              |
| 75                      | PU with steel                 | 9                          | 100                         | Deep groove ball bearings               | 1.0        | ± 0.30                 | 0.15        | 1.00              |
| 150                     | PU with steel                 | 15                         | 100                         | Deep groove ball bearings               | 5.0        | ± 0.30                 | 0.15        | 1.25              |
| 100                     | Neoprene with GF              | 15                         | 50                          | Deep groove ball bearings               | 2.0        | ± 0.35                 | 0.1         | 0.5               |
| 200                     | Neoprene with GF              | 16                         | 150                         | Deep groove ball bearings               | 3.0        | ± 0.30                 | 0.2         | 1.75              |
| 300                     | PU with steel                 | 16                         | 200                         | Deep groove ball bearings               | 5.0        | ± 0.20                 | 0.3         | 2.40              |
| 300                     | TPOUKF2                       | 16                         | 200                         | Cold ball bearing                       | 5.0        | ± 0.20                 | 0.3         | 2.40              |
| 100                     | PU + Aramid                   | 16                         | 50                          | xiros® ball bearings                    | 1.0        | ± 0.50                 | 0.15        | 0.50              |
| 200                     | PU + stainless steel          | 16                         | 200                         | Stainless steel ball bearing            | 5.0        | ± 0.20                 | 0.30        | 2.40              |
| 100                     | Neoprene with GF              | 16                         | 150                         | Deep groove ball bearings               | 1.5        | ± 0.30                 | 0.15        | 1.75              |
| 150                     | PU with steel                 | 16                         | 200                         | Deep groove ball bearings               | 2.5        | ± 0.20                 | 0.25        | 2.40              |
| 300                     | PU with steel                 | 16                         | 200                         | Deep groove ball bearings               | 5.0        | ± 0.20                 | 0.25        | 2.40              |
| 300                     | Neoprene with GF              | 15                         | 200                         | Deep groove ball bearings               | 5.0        | ± 0.20                 | 0.35        | 2.50              |
| 300                     | Neoprene with GF              | 15                         | 200                         | Deep groove ball bearings               | 5.0        | ± 0.20                 | 0.35        | 2.50              |
| 300                     | Neoprene with GF              | 15                         | 200                         | Deep groove ball bearings               | 5.0        | ± 0.20                 | 0.35        | 2.50              |
| 2,000                   | PU with steel                 | 32                         | 500                         | Deep groove ball bearings               | 5.0        | ± 0.20                 | 0.4         | 10.00             |
| 3,000                   | PU with stainless steel       | 20                         | 750                         | Deep groove ball bearings               | 5.0        | ± 0.20                 | 1.0         | 15.00             |
| 750                     | PU (FDA) with stainless steel | 20                         | 750                         | FDA-compliant deep groove ball bearings | 5.0        | ± 0.20                 | 1.0         | 15.00             |
| 3,000                   | PU with stainless steel       | 20                         | 750                         | Deep groove ball bearings               | 5.0        | ± 0.20                 | 1.0         | 15.00             |
| 3,000                   | PU with stainless steel       | 20                         | 750                         | Deep groove ball bearings               | 5.0        | ± 0.20                 | 1.0         | 15.00             |

The technical values in the specifications are maximum values for each criterion, e.g. speed, stroke length etc.; they are not cumulative values. Suitability under consideration of the individual parameters for usage can be checked online at [www.igus.eu/linearmodule-finder](http://www.igus.eu/linearmodule-finder).

## Drive pin alignment for all ZLW toothed belt axis

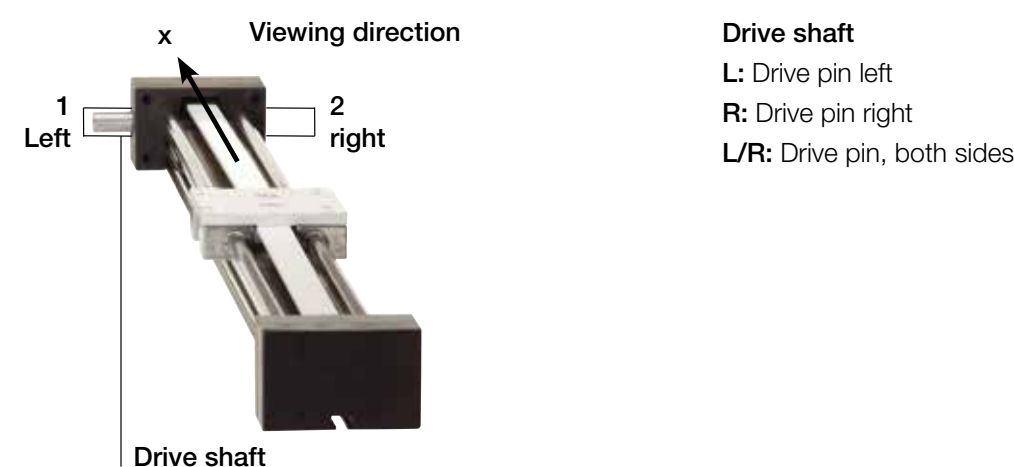

# drylin® ZLW-0630 | Technical data

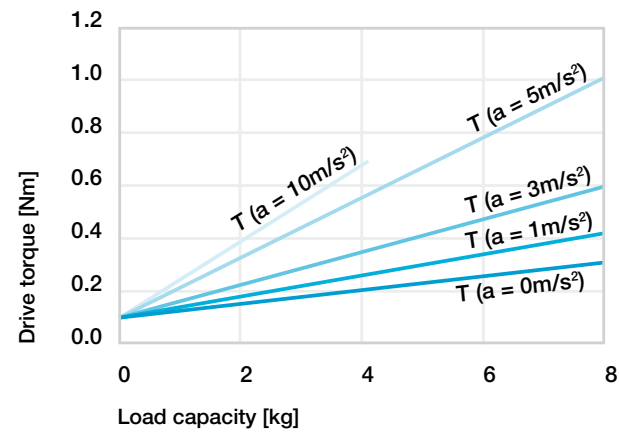

Diagram 01: Required drive torque<sup>138)</sup>; horizontal orientation - ZLW-0630, version basic 02

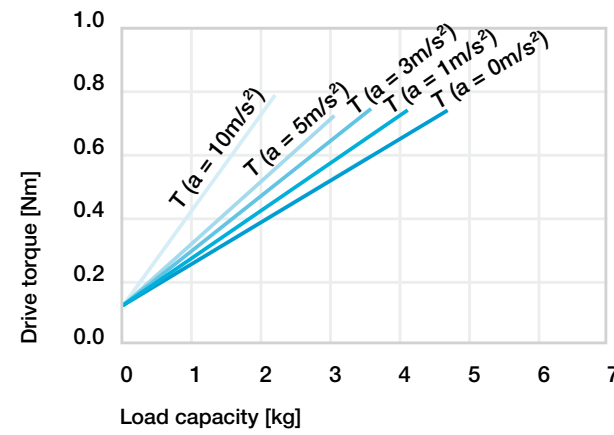

Diagram 02: Required drive torque<sup>138)</sup>; vertical orientation - ZLW-0630, version basic 02

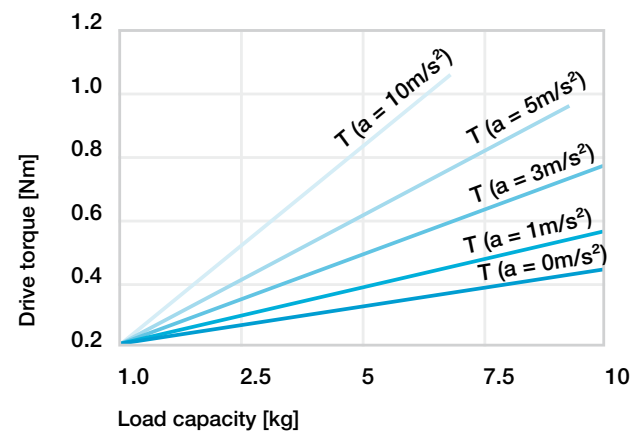

Diagram 03: Required drive torque<sup>138)</sup>; horizontal orientation - ZLW-0630, version standard 02

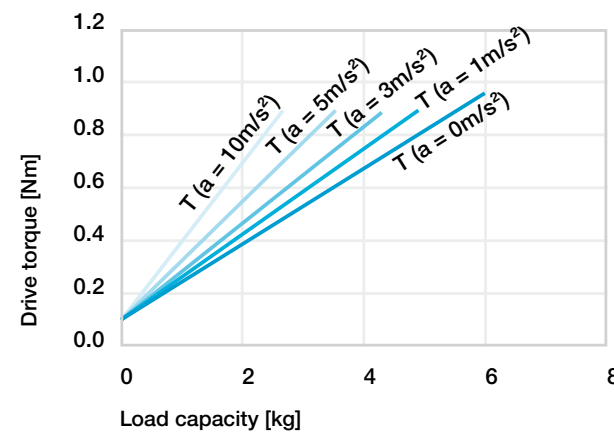

Diagram 04: Required drive torque<sup>138)</sup>; vertical orientation - ZLW-0630, version standard 02

<sup>138)</sup> Assumption: The moving mass is located in a circumscribed circle with a max. R = 100mm to the middle of the guiding rail, max. permissible torque, ZLW-0630 basic 02: 0.75Nm, a = 0m/s<sup>2</sup>, ZLW-0630 standard 02: 1Nm, a = 0m/s<sup>2</sup>, constant drive without nominal acceleration value

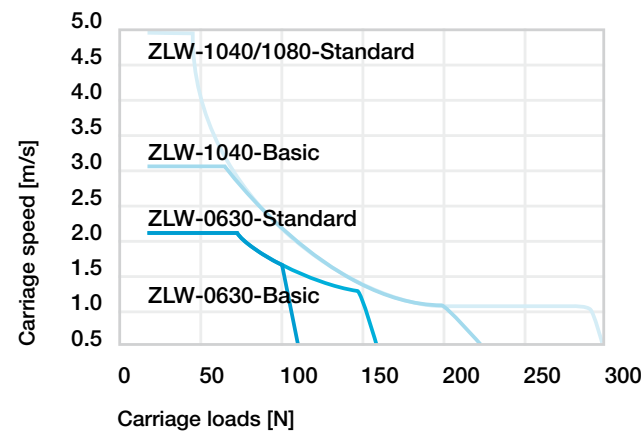

Diagram 05: Maximum load compared: ZLW-0630 and ZLW-1040/1080, 60% ED (duty cycle). The graph accounts for the sum of all forces active on the carriage.

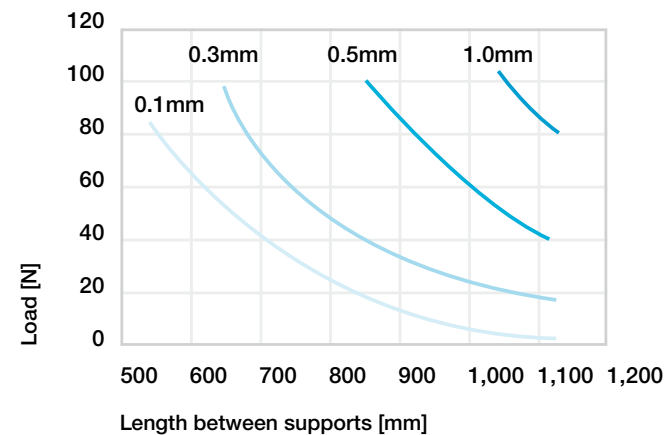

Diagram 06: Sag between unsupported end blocks ZLW-0630, basic 02 and standard 02 version. Sag permissible up to 2mm maximum.

# drylin® ZLW-1040/1080 | Technical data

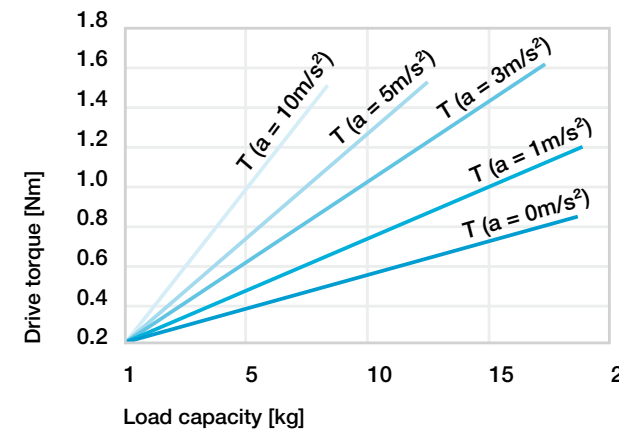

Diagram 07: Required drive torque<sup>139)</sup>; horizontal orientation - ZLW-1040, version basic 02

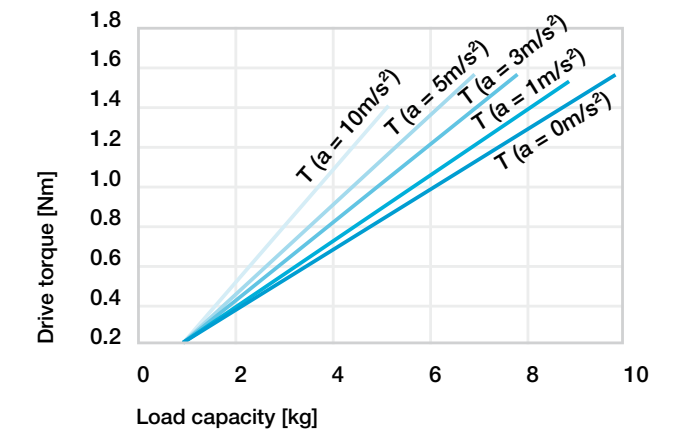

Diagram 08: Required drive torque<sup>139)</sup>; vertical orientation - ZLW-1040, basic 02 version

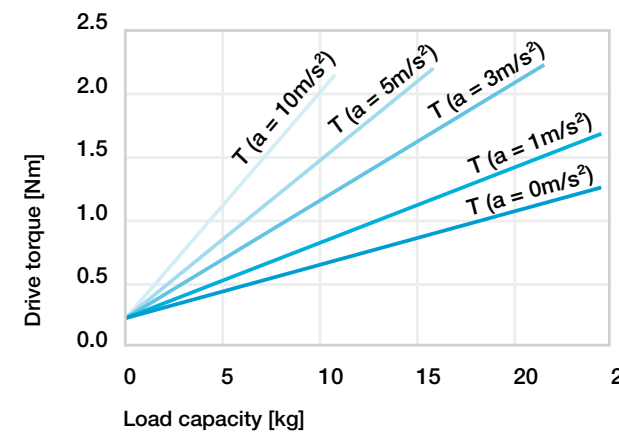

Diagram 09: Required drive torque<sup>139)</sup>; horizontal orientation - ZLW-1040/1080, version standard 02

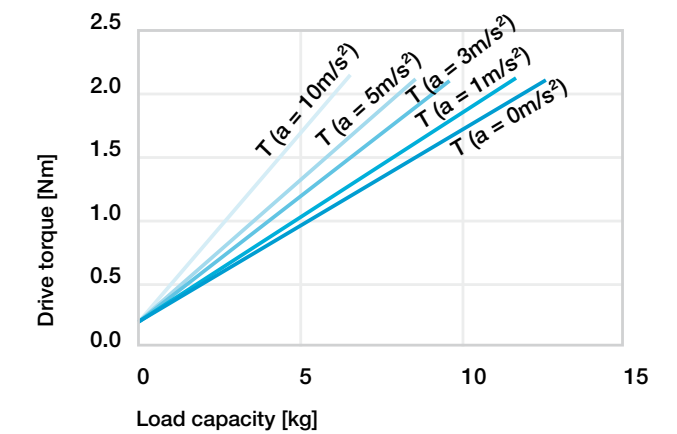

Diagram 10: Required drive torque<sup>139)</sup>; vertical orientation - ZLW-1040/1080, version standard 02

<sup>139)</sup> Assumption: The moving mass is located in a circumscribed circle with a max. R = 100mm to the middle of the guiding rail, max. permissible torque ZLW-1040/1080 basic 02: 1.75Nm, a = 0m/s<sup>2</sup>, ZLW-1040/1080 standard 02: 2.4Nm, a = 0m/s<sup>2</sup>, constant drive without nominal acceleration value

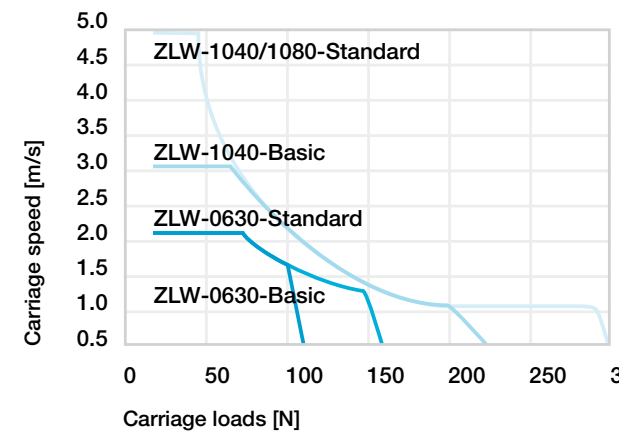

Diagram 11: Maximum load compared: ZLW-0630 and ZLW-1040/1080, 100% ED (duty cycle). The graph accounts for the sum of all forces active on the carriage.

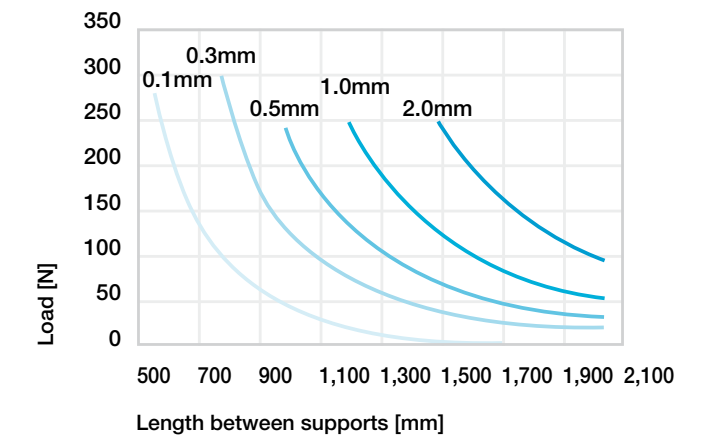

Diagram 12: Sag between unsupported end blocks ZLW-1040, basic version and ZLW-1040/1080 standard 02 version. Sag permissible up to 2mm maximum - horizontal orientation



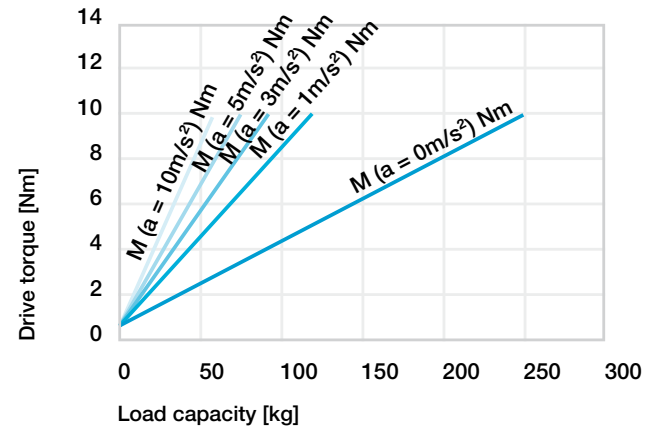

Diagram 13: Required drive torque<sup>140)</sup>; horizontal orientation - ZLW-1660, standard 02 version

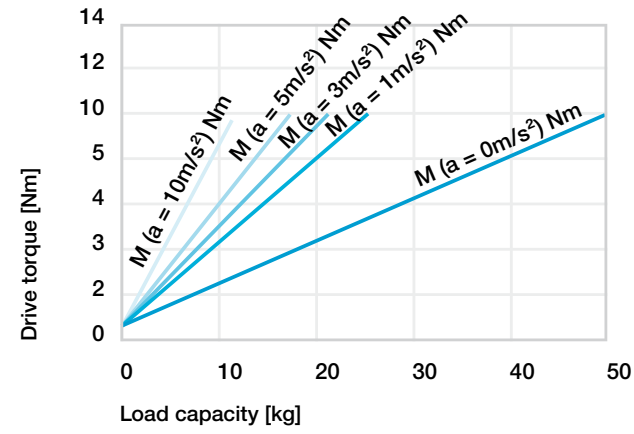

Diagram 14: Required drive torque<sup>140)</sup>; vertical orientation - ZLW-1660, standard 02 version

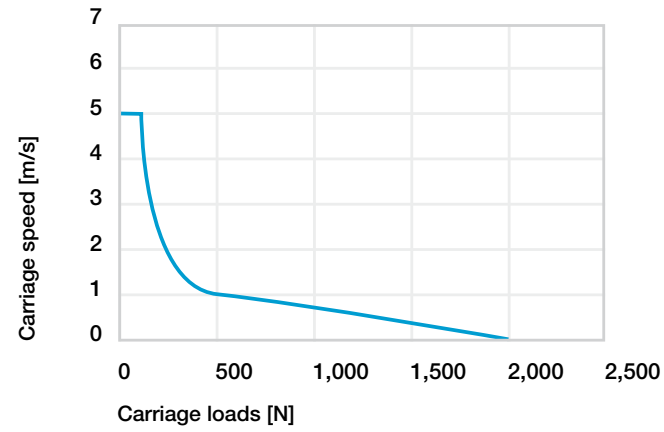

Diagram 15: Maximal load, horizontal installation; the graph accounts for the sum of all forces active on the carriage.

<sup>140)</sup> Assumption: The moving mass is located in a circumscribed circle with  $R = 100\text{mm}$  to the middle of the guiding rail, max. permissible torque ZLW-1660 standard 02:  $10\text{Nm}$ ,  $a = 0\text{m/s}^2$ , constant drive without nominal acceleration value

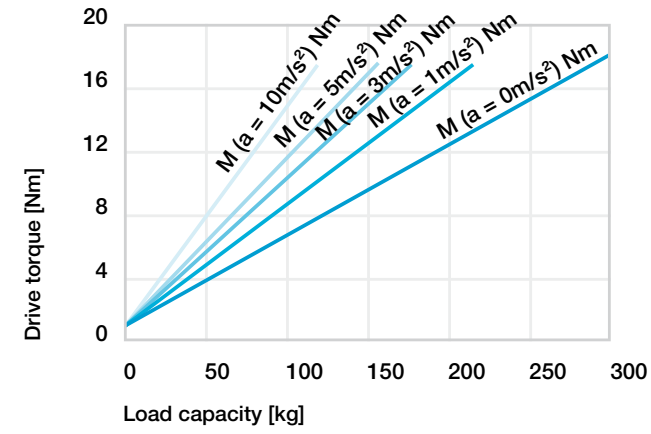

Diagram 17: Required drive torque<sup>140)</sup>; horizontal orientation - ZLW-20120, version standard 02

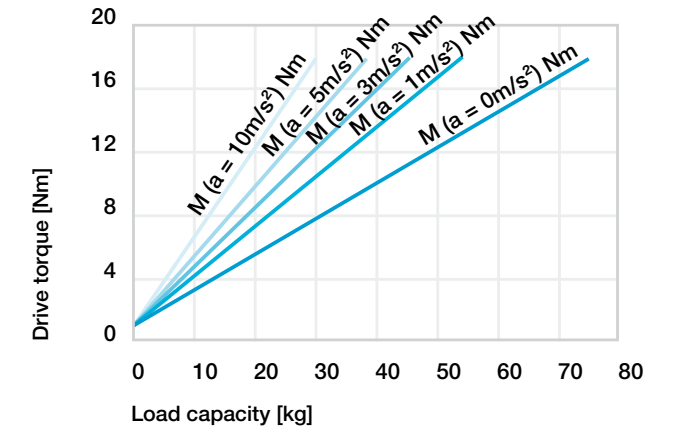

Diagram 16: Required drive torque<sup>140)</sup>; vertical orientation - ZLW-20120, version standard 02

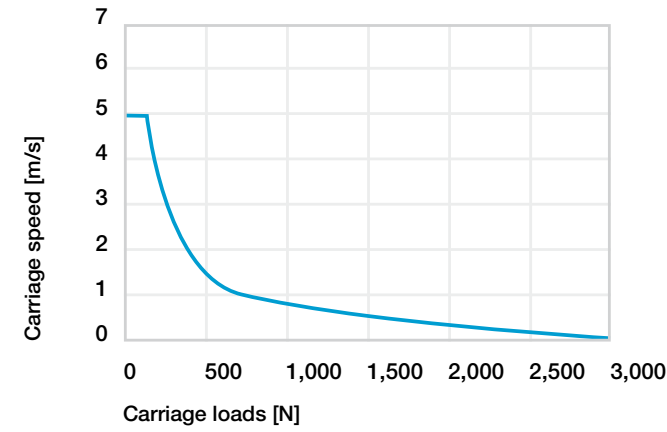

Diagram 18: Maximal load, horizontal installation; the graph accounts for the sum of all forces active on the carriage.

<sup>174)</sup> Assumption: The moving mass is located in a circumscribed circle with  $R = 100\text{mm}$  to the middle of the guiding rail, max. permissible torque:  $20\text{Nm}$ ,  $a = 0\text{m/s}^2$ , constant drive without nominal acceleration value

Technical data

| Part No. | Geometrical moment of inertia |           | Moment of resistance |          |
|----------|-------------------------------|-----------|----------------------|----------|
|          | $I_y$                         | $I_z$     | $W_{by}$             | $W_{bz}$ |
| ZLW-0630 | 30,391                        | 11,674    | 1,736                | 845      |
| ZLW-0660 | 212,826                       | 17,018    | 6,448                | 1,398    |
| ZLW-1040 | 97,560                        | 54,910    | 3,902                | 3,076    |
| ZLW-1080 | 483,653                       | 486,613   | 11,515               | 4,684    |
| ZLW-1660 | 540,876                       | 4,773,489 | 14,618               | 24,586   |



**econ series**

Many infeed movements require cost-effective linear axes that focus on pure adjustment tasks. This econ series with toothed belt was developed for the fast positioning of light loads. With its compact design and being lightweight due to aluminium and plastic, the ZLW econ is the perfect alternative to self-made solutions.



**Basic series**

Lubrication-free linear guide also driven by a toothed belt made from fibre-glass reinforced neoprene (black). The drive shaft, consisting of a square stainless steel and toothed pulley made of high-performance polymer, rests on 2 deep groove ball bearings. The drive pin is 6x6mm square and made of stainless steel. The scope of delivery includes a plastic adapter for a pin diameter of 10mm.



**Standard series**

The lubrication-free linear guide is also driven by a toothed belt made from steel reinforced polyurethane (white). Deflection shaft and drive pulley (single-piece) are made from plated steel or stainless steel. The pulley shafts are mounted in two deep groove ball bearings.



**Modular kit series**

A high degree of flexibility characterises the ZLW modular system series. A modular construction system based on individual rails from the drylin® W linear system. 3 widths up to 200mm, 8M PU with stainless steel reinforcement for smooth running, either in aluminium or stainless steel.



The ZLW specialists

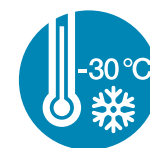

**LT**

For use at temperatures down to -30°C, the drive and deflection shaft end supports are fitted with ball bearings. Drive is a toothed belt suitable for low temperatures.



**UW**

Maximum protection against corrosion is provided by the toothed belt axis; for underwater applications, among others. Linear carriages, drive and deflection shaft end supports made of anodised aluminium, incl. lubrication-free xiros® ball bearings. A flexible toothed belt with aramid reinforcing serves as the belt.



**SW**

The SW ZLW version is suitable for applications where there is contact with spray water. Corrosion-resistant due to PU toothed belt with stainless steel tie beams and stainless steel ball bearings, as well as shaft end support housing made of anodised aluminium.



**ES**

The ZLW modular axis made of stainless steel offers maximum corrosion protection. All components are manufactured in stainless steel, driven by 8M PU toothed belt with stainless steel reinforcing.



More Information online

► [www.igus.eu/ZLW](http://www.igus.eu/ZLW)



- Fast positioning of small loads
- Quiet operation and flat design
- Drive pin on one or both sides
- Linear carriages available in different lengths (except for econ version)
- Configurable with motor as a ready-to-install linear drive
- Specialist in deep-freeze, underwater and spray-water areas ► **Page 585**

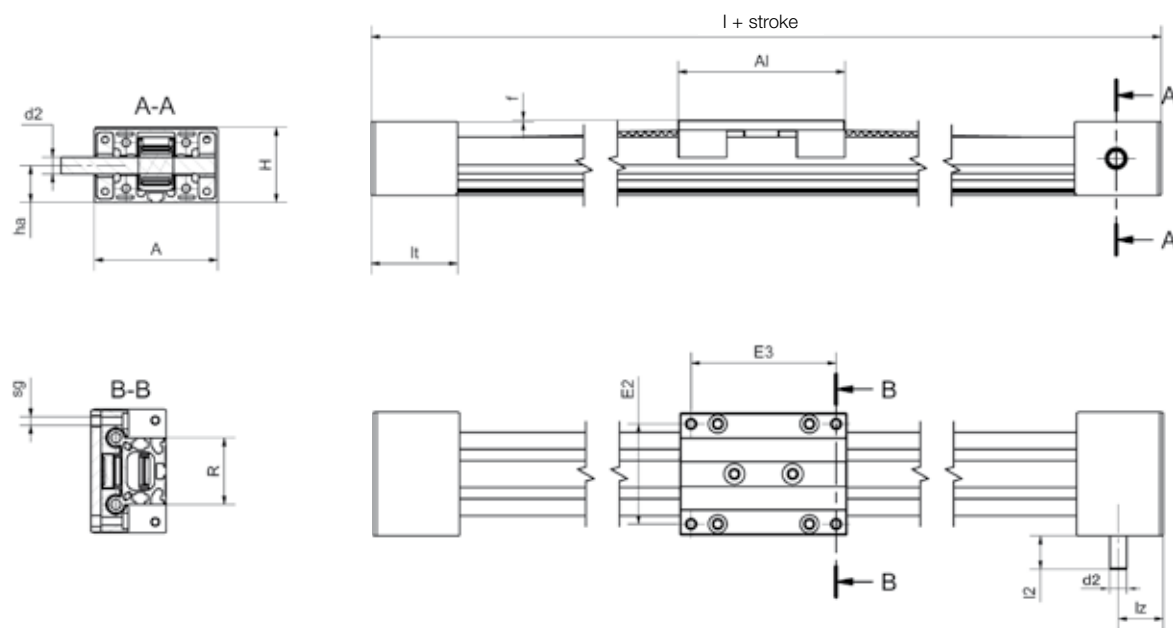

### Connecting dimensions

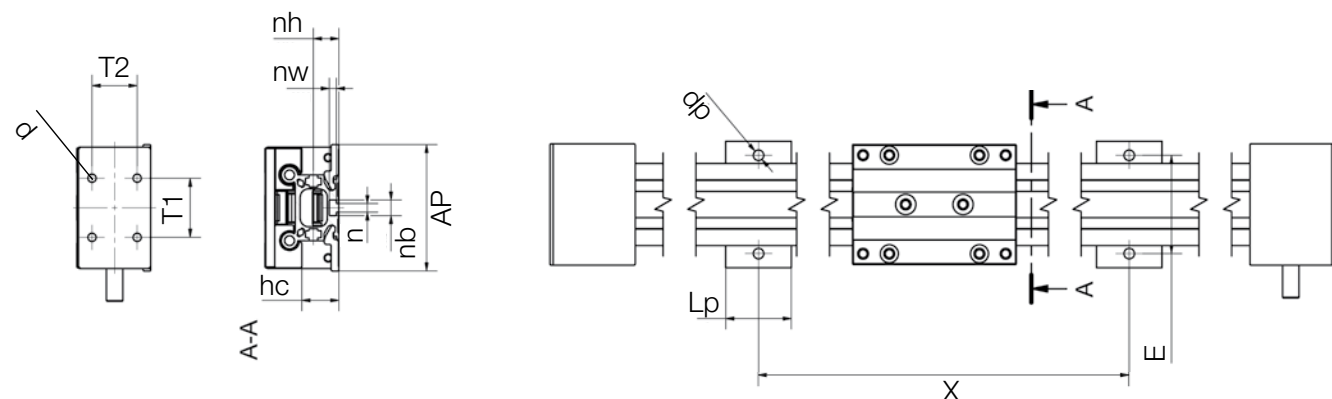

### Order key

Order example

## ZLW-0630-02-B



Options:

Version

02: With deep groove ball bearings

Design

E: econ series (630/1040)  
B: basic series (0630/1040)  
S: Standard series (all sizes)

### Order key specialists

Order example

## ZLW-1040-LT-02-S



Options:

Version

LT: For deep-freeze applications down to -30°C

UW: For underwater applications

SW: For spray-water applications

Version

02: With deep groove ball bearings

Design

S: Standard series

### Dimensions [mm]

| Part No.         | A    | AI  | H  | E2    | E3    | I   | R     | f | lt   | sg | ha | hc   | lz   | l2   | d2 |
|------------------|------|-----|----|-------|-------|-----|-------|---|------|----|----|------|------|------|----|
|                  | -0.3 |     |    | ±0.15 | ±0.15 |     | ±0.15 |   | ±0.3 |    |    |      |      |      | h9 |
| ZLW-0630-02      | 54   | 60  | 31 | 45    | 51    | 144 | 30    | 3 | 42   | M4 | 14 | 22.5 | 20.5 | 20   | 8  |
| ZLW-0660         | 85   | 100 | 31 | 76    | 91    | 184 | 61    | 3 | 42   | M4 | 14 | 22.5 | 20.5 | 19.5 | 8  |
| ZLW-1040-02      | 74   | 100 | 44 | 60    | 87    | 204 | 40    | 1 | 52   | M6 | 22 | 22.5 | 27   | 20   | 10 |
| ZLW-1040-LT-02-S | 74   | 100 | 44 | 60    | 87    | 204 | 40    | 1 | 52   | M6 | 22 | 22.5 | 27   | 20   | 10 |
| ZLW-1040-UW-02-S | 74   | 100 | 44 | 60    | 87    | 204 | 40    | 1 | 52   | M6 | 22 | 22.5 | 27   | 20   | 10 |
| ZLW-1040-SW-02-S | 74   | 100 | 44 | 60    | 87    | 204 | 40    | 1 | 52   | M6 | 22 | 22.5 | 27   | 20   | 10 |
| ZLW-1080-02      | 90   | 100 | 44 | 94    | 87    | 204 | 74    | 1 | 52   | M6 | 22 | 22.5 | 24.5 | 12   | 10 |
| ZLW-1660-02      | 104  | 100 | 72 | 86    | 82    | 252 | 60    | 2 | 76   | M8 | 43 | 22.5 | 38   | 20   | 14 |

### Connecting dimensions [mm]

| Part No.                    | X        | E    | AP   | Lp | dp  | n   | nb   | nw   | nh   | T1    | T2    | d   |
|-----------------------------|----------|------|------|----|-----|-----|------|------|------|-------|-------|-----|
|                             |          | ±0.2 | -1.0 |    |     |     |      |      |      | ±0.25 | ±0.25 |     |
| ZLW-0630-02 <sup>109)</sup> | variable | 40   | 52   | 15 | 5.5 | -   | -    | 4.3  | 7    | 20    | 21    | 3.2 |
| ZLW-0660                    | variable | 71   | 52   | 15 | 5.5 | 5.2 | 9.5  | 4.3  | 7    | 20    | 21    | 3.2 |
| ZLW-1040-02                 | variable | 60   | 78   | 40 | 6.4 | 5.2 | 9.5  | 4.3  | 15.5 | 36    | 26.5  | 5.0 |
| ZLW-1040-LT-02-S            | variable | 60   | 78   | 40 | 6.4 | 5.2 | 9.5  | 4.3  | 15.5 | 36    | 26.5  | 5.0 |
| ZLW-1040-UW-02-S            | variable | 60   | 78   | 40 | 6.4 | 5.2 | 9.5  | 4.3  | 15.5 | 36    | 26.5  | 5.0 |
| ZLW-1040-SW-02-S            | variable | 60   | 78   | 40 | 6.4 | 5.2 | 9.5  | 4.3  | 15.5 | 36    | 26.5  | 5.0 |
| ZLW-1080-02                 | variable | 94   | 111  | 40 | 6.4 | 5.2 | 9.5  | 4.36 | 15.5 | 36    | 27    | M6  |
| ZLW-1660-02                 | variable | 100  | 122  | 40 | 9   | 10  | 15.4 | 13   | 27.6 | 65    | 60    | M5  |

<sup>109)</sup> Basic version: 6mm square, plastic adapter for pin diameter 10mm included



Aluminium version

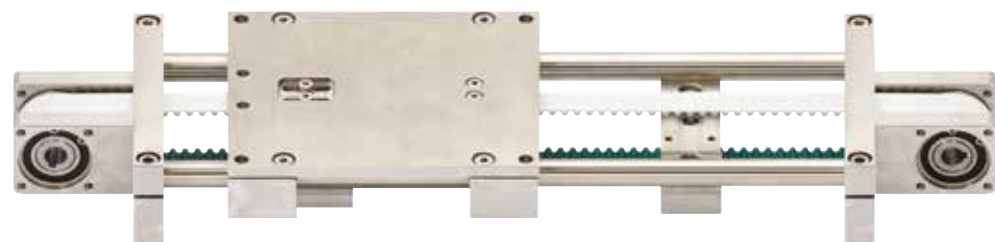

Stainless steel version



ZLWA design with exchangeable liners

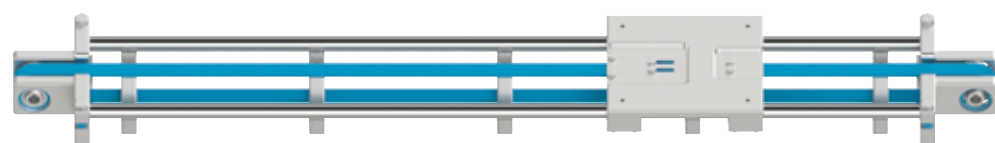

Hygienic design  
► Page 590



Tandem toothed belt axis  
► Page 591

### Technical data

| Part No.                  | Max. stroke length |             | Transmission<br>[mm/rev] | Tooth profile | Toothed belt material                 | Toothed belt tension<br>[N] |
|---------------------------|--------------------|-------------|--------------------------|---------------|---------------------------------------|-----------------------------|
|                           | -ES<br>[mm]        | -AL<br>[mm] |                          |               |                                       |                             |
| ZLW-10120 <sup>166)</sup> | 2,000              | 2,000       | 75                       | 3M            | Neoprene with fibre glass             | 200                         |
| ZLW-10160 <sup>166)</sup> | 2,000              | 2,000       | 75                       | 3M            | Neoprene with fibre glass             | 200                         |
| ZLW-10200 <sup>166)</sup> | 2,000              | 2,000       | 75                       | 3M            | Neoprene with fibre glass             | 200                         |
| ZLW-20120                 | 2,500              | 3,000       | 144                      | 8M            | PU with stainless steel reinforcement | 750                         |
| ZLW-20160                 | 2,500              | 3,000       | 144                      | 8M            | PU with stainless steel reinforcement | 750                         |
| ZLW-20200                 | 2,500              | 3,000       | 144                      | 8M            | PU with stainless steel reinforcement | 750                         |

<sup>166)</sup> Option for WJ200UMA pillow blocks with exchangeable liners, ZLWA-□



Order key



Order example

**ZLW A -20120-AL**

|                   |             |                   |               |        |
|-------------------|-------------|-------------------|---------------|--------|
| Toothed belt axis | Replaceable | Installation size | Axis distance | Design |
|-------------------|-------------|-------------------|---------------|--------|

- High speed with ball bearing supported drive shaft
- Robust wide round belt
- Central belt adjustment on the carriage
- Based on lubrication-free drylin® W linear guide
- Variable motor connection due to solid and hollow shafts

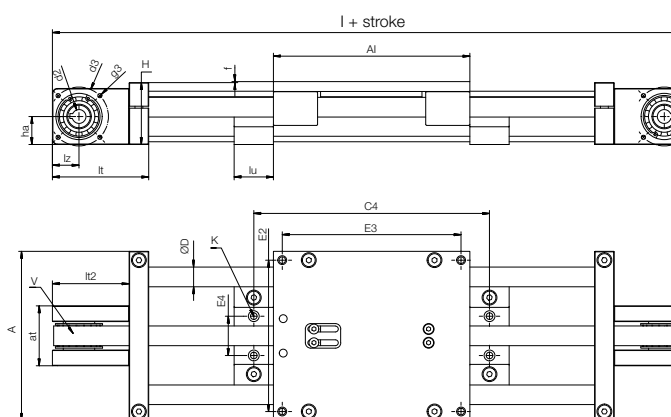

Options:

Axis distance  
120: 120mm  
160: 160mm  
200: 200mm

Design

AL: Aluminium  
ES: Stainless steel  
Carriage length  
200: 200mm

Drive shaft

Hollow shaft  
Stroke length  
Max. 3.000mm (AL)  
Max. 2,500mm (SS)

### Dimensions [mm]

| Part No.  | A   | Al  | H    | E2  | E3  | E4  | C4  | f | lt | ha   | lz | l   |
|-----------|-----|-----|------|-----|-----|-----|-----|---|----|------|----|-----|
| ZLW-10120 | 153 | 150 | 40.0 | 140 | 137 | 40  | 240 | 1 | 74 | 18.0 | 18 | 198 |
| ZLW-10160 | 193 | 150 | 40.0 | 180 | 177 | 90  | 240 | 1 | 74 | 18.0 | 18 | 198 |
| ZLW-10200 | 233 | 150 | 40.0 | 220 | 217 | 120 | 240 | 1 | 74 | 18.0 | 18 | 198 |
| ZLW-20120 | 172 | 200 | 63.0 | 154 | 182 | 40  | 240 | - | 98 | 28.5 | 27 | 396 |
| ZLW-20160 | 212 | 200 | 63.0 | 194 | 182 | 80  | 240 | - | 98 | 28.5 | 27 | 396 |
| ZLW-20200 | 252 | 200 | 63.0 | 234 | 182 | 120 | 240 | - | 98 | 28.5 | 27 | 396 |

| Part No.  | d2 | d3 | g3 | D  | K                  | at | lt2 | lu | V        |
|-----------|----|----|----|----|--------------------|----|-----|----|----------|
|           | H7 |    |    |    | For DIN912 - M6    |    |     |    | [mm/rev] |
| ZLW-10120 | 10 | 38 | M4 | 10 | M6 <sup>158)</sup> | 43 | 59  | 20 | 75       |
| ZLW-10160 | 10 | 38 | M4 | 10 | M6 <sup>158)</sup> | 43 | 59  | 20 | 75       |
| ZLW-10200 | 10 | 38 | M4 | 10 | M6 <sup>158)</sup> | 43 | 59  | 20 | 75       |
| ZLW-20120 | 14 | 60 | M5 | 20 | M8                 | 61 | 78  | 40 | 144      |
| ZLW-20160 | 14 | 60 | M5 | 20 | M8                 | 61 | 78  | 40 | 144      |
| ZLW-20200 | 14 | 60 | M5 | 20 | M8                 | 61 | 78  | 40 | 144      |

<sup>158)</sup> For DIN912 - M5



Linear axis with hygienic design

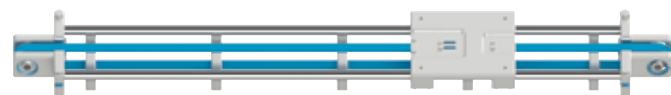

Order example

## ZLW-20120-HYD



- Linear axis compliant with hygienic design
- Bearing points FDA-compliant through iglidur® A160
- Corrosion-resistant

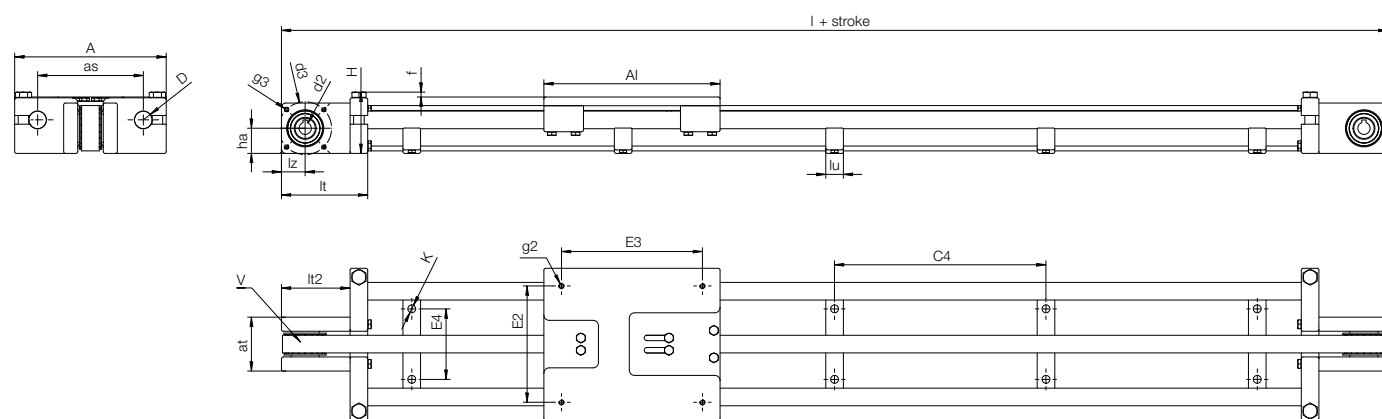

### Technical data

| Part No.                 | Max. stroke length<br>[mm] | Transmission<br>[mm/rev] | Tooth profile | Toothed belt material      | Toothed belt tension<br>[N] | Weight<br>[kg] | addit.<br>(per 100mm)<br>[kg] |
|--------------------------|----------------------------|--------------------------|---------------|----------------------------|-----------------------------|----------------|-------------------------------|
| ZLW-20120-HYD <b>New</b> | 3,000                      | 144                      | 8M            | PU (FDA) + stainless steel | 750                         | 2.03           | 0.16                          |

### Dimensions [mm]

| Part No.                 | A   | AI  | H    | E2  | E3    | E4 | C4  | f   | It | ha   | Iz | I   |
|--------------------------|-----|-----|------|-----|-------|----|-----|-----|----|------|----|-----|
| ZLW-20120-HYD <b>New</b> | 172 | 200 | 69.4 | 132 | AI-40 | 80 | 240 | 5.4 | 98 | 28.5 | 27 | 396 |

| Part No.                 | d2<br>H7 | d3 | g3 | D  | K<br>For DIN912 - M6 | at | It2 | Iu | V<br>[mm/rev] |
|--------------------------|----------|----|----|----|----------------------|----|-----|----|---------------|
| ZLW-20120-HYD <b>New</b> | 14       | 60 | M5 | 20 | 9                    | 61 | 78  | 20 | 144           |

Tandem toothed belt axis



Order example

## ZLWT-10160



- Addition to the tandem toothed belt axis installation size 10/20
- Compact tandem toothed belt axis with two drive belts in one unit
- Two carriages can be controlled synchronously or separately
- With drylin® W exchange bearings for fast bearing exchange on the rail
- Can be supplied ready-to-connect with igus® motors and drylin® D1 dryve motor control system

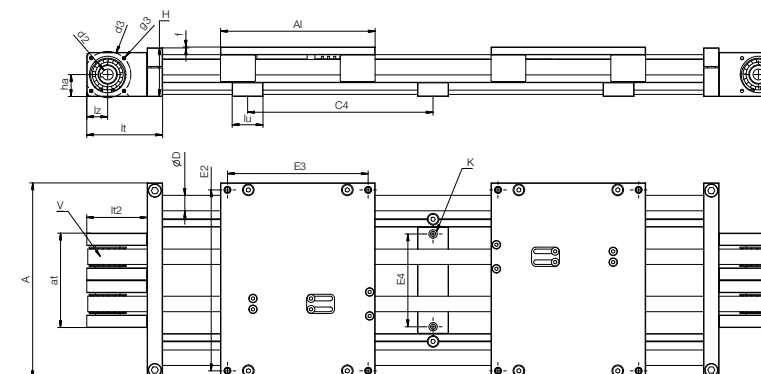

### Technical data

| Part No.   | Max. stroke length<br>[mm] | Transmission<br>[mm/rev] | Tooth profile | Drive belt Material                   | Drive belt Tension<br>[N] | Weight<br>[kg] | addit.<br>(per 100mm)<br>[kg] |
|------------|----------------------------|--------------------------|---------------|---------------------------------------|---------------------------|----------------|-------------------------------|
| ZLWT-10160 | 2,000                      | 75                       | 3M            | Neoprene with fibre glass             | 200                       | 4.0            | 0.25                          |
| ZLWT-10200 | 2,000                      | 75                       | 3M            | Neoprene with fibre glass             | 200                       | 4.5            | 0.30                          |
| ZLWT-20200 | 3,000                      | 144                      | 8M            | PU with stainless steel reinforcement | 750                       | 11.0           | 0.50                          |
| ZLWT-20300 | 3,000                      | 144                      | 8M            | PU with stainless steel reinforcement | 750                       | 12.5           | 0.65                          |

### Dimensions [mm]

| Part No.   | A   | AI              | H  | E2  | E3    | E4  | C4  | f | It | ha   | Iz | I   | d2<br>h7 |
|------------|-----|-----------------|----|-----|-------|-----|-----|---|----|------|----|-----|----------|
| ZLWT-10160 | 193 | 150/200/250     | 40 | 180 | AI-13 | 90  | 240 | 1 | 74 | 18,0 | 18 | 448 | 10       |
| ZLWT-10200 | 233 | 150/200/250     | 40 | 220 | AI-13 | 120 | 240 | 1 | 74 | 18,0 | 18 | 448 | 10       |
| ZLWT-20200 | 252 | 200/250/300/350 | 63 | 234 | AI-18 | 120 | 240 | 1 | 98 | 28,5 | 27 | 596 | 14       |
| ZLWT-20300 | 352 | 200/250/300/350 | 63 | 334 | AI-18 | 200 | 240 | 1 | 98 | 28,5 | 27 | 596 | 14       |

| Part No.   | d3 | g3 | D  | K<br>For DIN912 - M6 | at  | It2 | Iu | V<br>[mm/rev] |
|------------|----|----|----|----------------------|-----|-----|----|---------------|
| ZLWT-10160 | 38 | M4 | 10 | M6                   | 107 | 59  | 20 | 75            |
| ZLWT-10200 | 38 | M4 | 10 | M6                   | 107 | 59  | 20 | 75            |
| ZLWT-20200 | 60 | M5 | 20 | M8                   | 122 | 78  | 40 | 144           |
| ZLWT-20300 | 60 | M5 | 20 | M8                   | 122 | 78  | 40 | 144           |

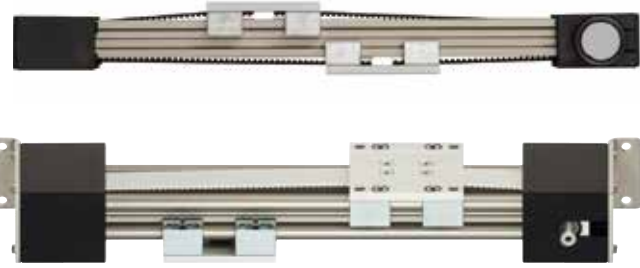

- Quick reverse positioning
- Fast right/left adjustment
- Available as standard and basic version
- Incl. angle flange for fixing
- Individual stroke lengths up to max. 3,000mm
- Radial loads up to 200N

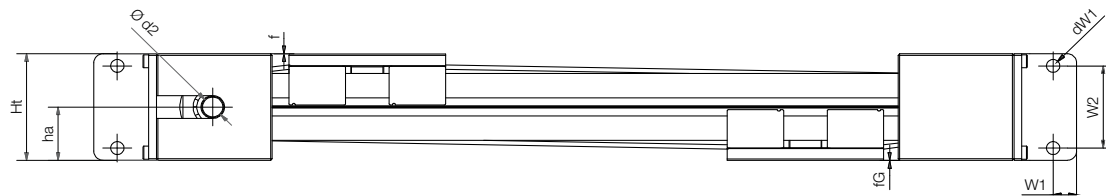

Angle flange alignment:

"02" version

mounted on the side, ZLW alignment on the edge

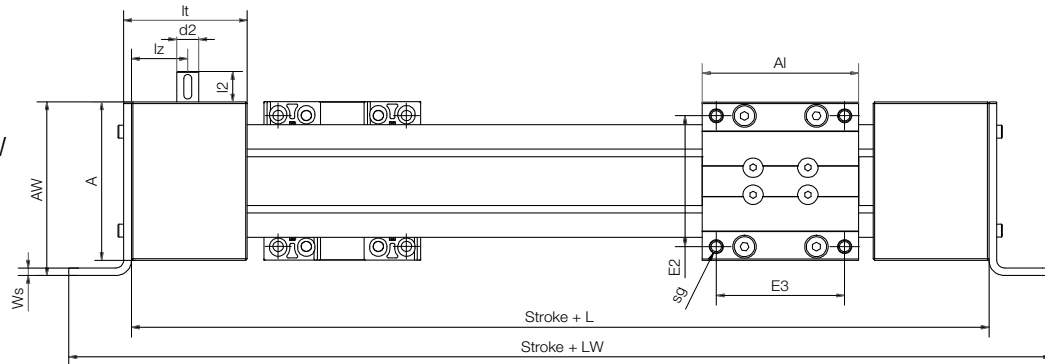

"04" version

mounted horizontally, ZLW alignment horizontal

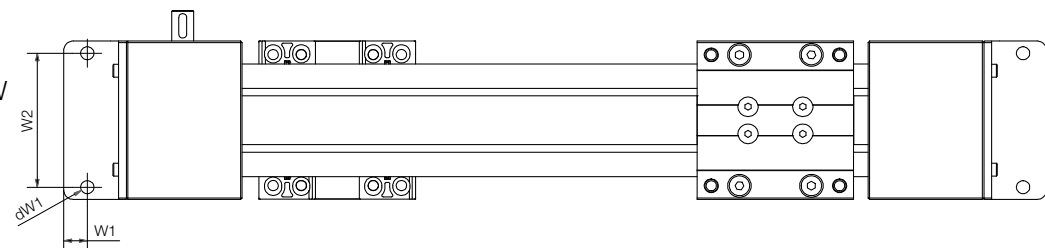

"03" version

mounted on the front

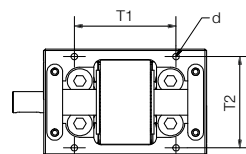

Order key

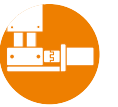

Order example

ZLW-1040-OD-02



Options:

Design

OD: Right/left opposite drive

Version

02: With deep groove ball bearings

Dimensions [mm]

| Part No.                    | A    | AI  | H  | Ht | E2    | E3    | L   | R     | f | fg | lt   | sg | ha | lz | Max. stroke length |
|-----------------------------|------|-----|----|----|-------|-------|-----|-------|---|----|------|----|----|----|--------------------|
|                             | -0.3 |     |    |    | ±0.15 | ±0.15 |     | ±0.15 |   |    | ±0.3 |    |    |    | [mm]               |
| ZLW-0630-OD <sup>109)</sup> | 54   | 60  | 31 | 28 | 45    | 51    | 144 | 30    | 3 | 7  | 42   | M4 | 14 | 20 | 1,000              |
| ZLW-1040-OD                 | 74   | 100 | 45 | 44 | 60    | 87    | 204 | 40    | 1 | 3  | 52   | M6 | 22 | 27 | 1,500              |
| ZLW-1660-OD-02              | 104  | 100 | 70 | 70 | 86    | 82    | 248 | 58    | 0 | 0  | 79   | M8 | 35 | 36 | 3,000              |
| ZLW-1660-OD-03              | 104  | 100 | 70 | 70 | 86    | 82    | 248 | 58    | 0 | 0  | 79   | M8 | 35 | 36 | 3,000              |
| ZLW-1660-OD-04              | 104  | 100 | 70 | 70 | 86    | 82    | 248 | 58    | 0 | 0  | 74   | M8 | 35 | 36 | 3,000              |

| Part No.                    | I2 | d2 | d          | T1    | T2    | Ws | W1 | W2 | dW1 | LW  | AW  |
|-----------------------------|----|----|------------|-------|-------|----|----|----|-----|-----|-----|
|                             |    | h9 |            | ±0.25 | ±0.25 |    |    |    |     |     |     |
| ZLW-0630-OD <sup>109)</sup> | 20 | 8  | 4          | 20    | 21    | 2  | 20 | 2  | 5.5 | 260 | 60  |
| ZLW-1040-OD                 | 20 | 10 | 5          | 36    | 26.5  | 3  | 25 | 3  | 6.6 | 296 | 80  |
| ZLW-1660-OD-02              | 20 | 14 | M5-10 deep | 65    | 60    | 5  | 15 | 54 | 8.5 | 328 | 114 |
| ZLW-1660-OD-03              | 20 | 14 | M5-10 deep | 65    | 60    | 5  | 15 | 88 | 8.5 | 328 | 75  |
| ZLW-1660-OD-04              | 20 | 14 | M5-10 deep | 65    | 60    | 5  | -  | -  | -   | 248 | 70  |

<sup>109)</sup> Basic version: 6mm square, plastic adapter for pin diameter 10mm included



Order key



Order example

ZLN-40

Toothed belt axis

Installation size

- Motor can now be mounted on the bottom as well as on top
- Low-profile design, 27mm height
- Vertical load from 30N
- Ready-to-install with NEMA stepper motors or BLDC/DC motors
- Delivery from 24 hours

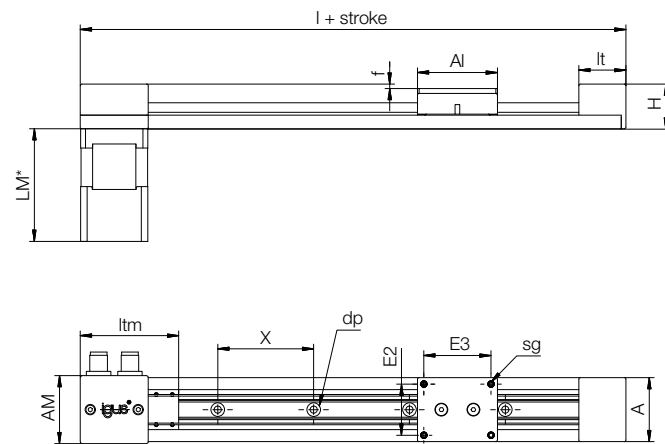

### Technical data

| Part No. | Max. stroke length<br>[mm] | Weight<br>[kg] | addit.<br>[kg]<br>(per 100mm) | Max. static load capacity |               | Shaft end support<br>material<br>[Nm] |
|----------|----------------------------|----------------|-------------------------------|---------------------------|---------------|---------------------------------------|
|          |                            |                |                               | axial<br>[N]              | radial<br>[N] |                                       |
| ZLN-40   | 750                        | 0.24           | 0.05                          | 30                        | 80            | 0.15                                  |

### Dimensions [mm]

| Part No. | A  | AI | H  | X  | E2 | E3 | AM   | LM | lt | ltm  | dp  | sg | l     | v  | f   |
|----------|----|----|----|----|----|----|------|----|----|------|-----|----|-------|----|-----|
| ZLN-40   | 40 | 50 | 28 | 60 | 32 | 42 | 42.5 | 70 | 30 | 61.5 | 4.5 | M3 | 141.5 | 60 | 2.8 |

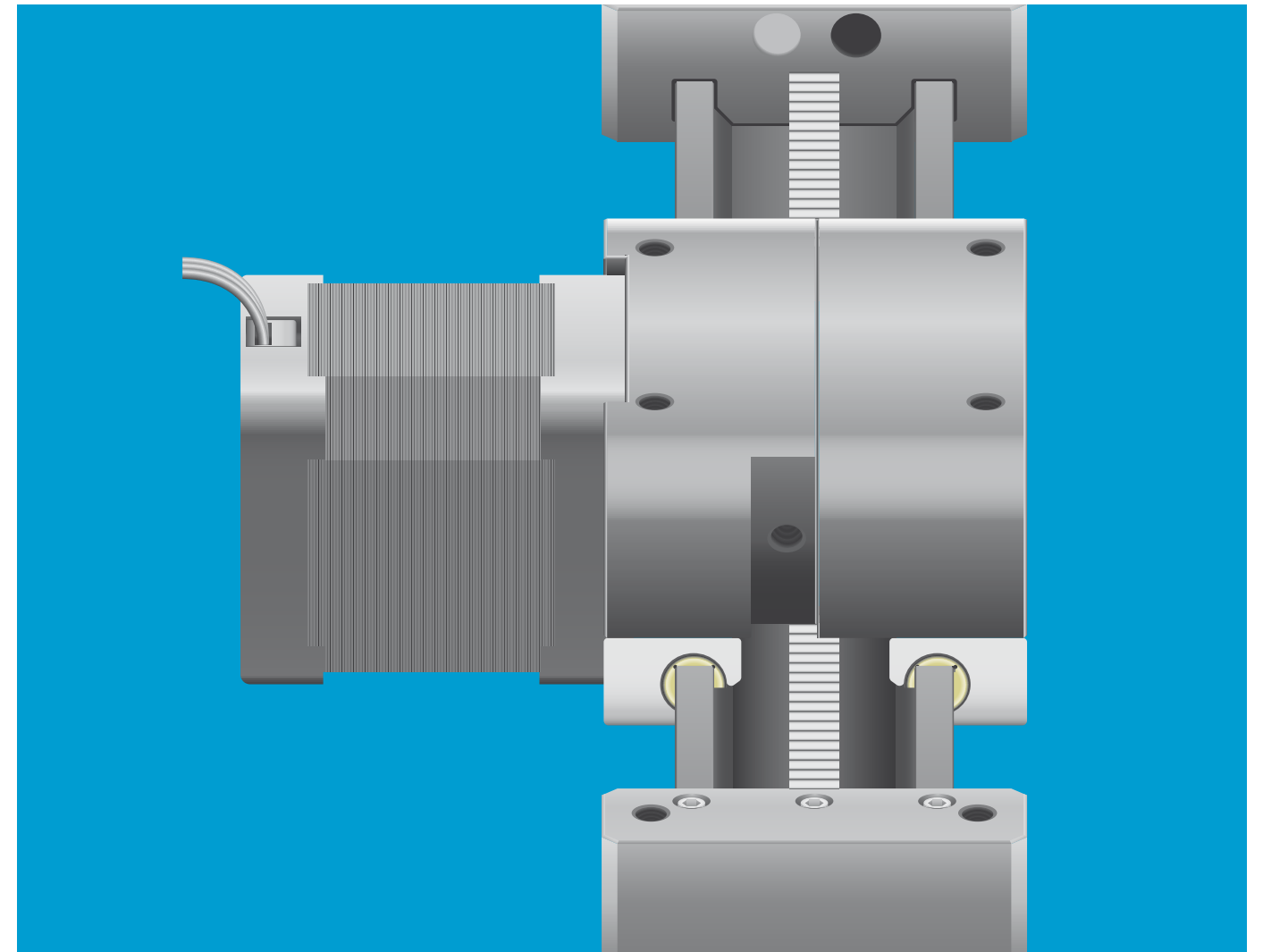

## drylin® electric drive technology - cantilever axes

High dynamics

Drive: Rack or toothed belt

Lightweight design

For z-axis in multi-axis gantries

Lubrication and maintenance-free



- Direct force transfer via rack
- Compact structure
- Handling for loads up to 10N
- Accessories available ► **Page 613**
- **Available with motor**

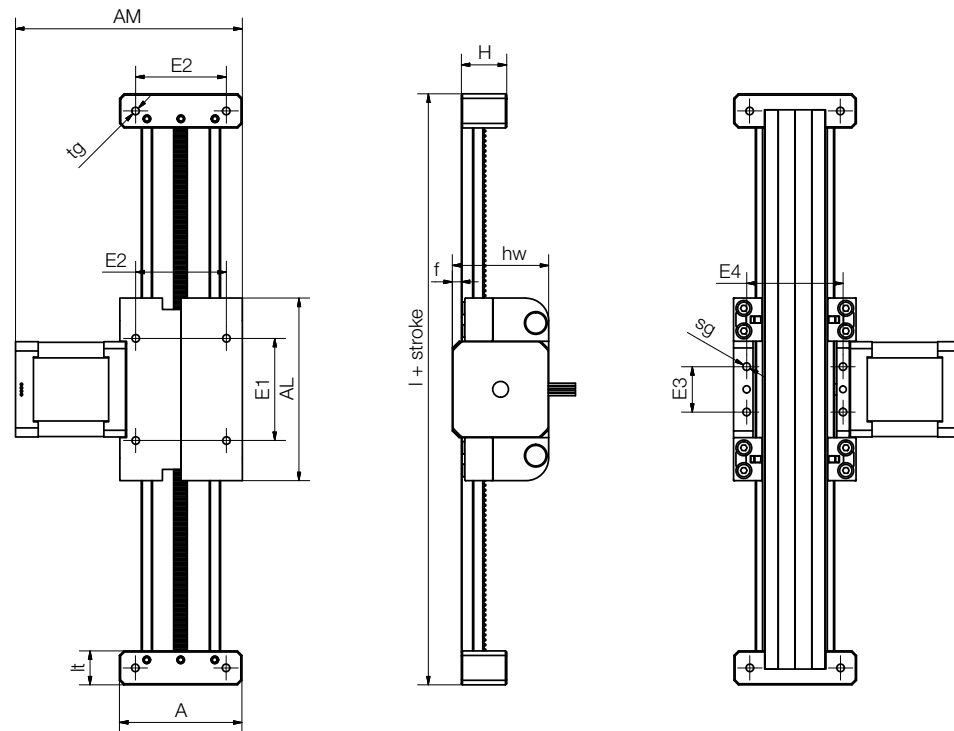

### Technical data

| Part No.   | Stroke length<br>[mm] | Weight<br>[kg] | Additional<br>(per 100mm) | Max. Feed rate<br>[mm/rev] | Max. Load<br>axial [N] |
|------------|-----------------------|----------------|---------------------------|----------------------------|------------------------|
| GRW-0630-A | 150                   | 0.5            | 0.1                       | 44                         | 10                     |
| GRW-0630-B | 300                   | 0.5            | 0.1                       | 44                         | 10                     |

### Dimensions [mm]

| Part No.   | A    | Al   | H  | E1    | E2    | E3 | E4   | I     | It | hw   | f | AM <sup>131)</sup> | tg | sg   |
|------------|------|------|----|-------|-------|----|------|-------|----|------|---|--------------------|----|------|
|            | -0.3 |      |    | +0.15 | +0.15 |    |      |       |    |      |   |                    |    |      |
| GRW-0630-A | 54   | 80.5 | 20 | 45    | 40    | 20 | 42.5 | 110.5 | 15 | 42.5 | 4 | 100.0              | M4 | M4-8 |
| GRW-0630-B | 54   | 80.5 | 20 | 45    | 40    | 20 | 42.5 | 110.5 | 15 | 42.5 | 4 | 121.4              | M4 | M4-8 |

<sup>131)</sup> Depending on the type of motor

- Toothed, hard-anodised, corrosion-resistant square hollow section
- Loads up to 500g with a speed of up to 0.7m/s
- iglidur® J plain bearings
- Drive: NEMA11 stepper motor with gear wheel

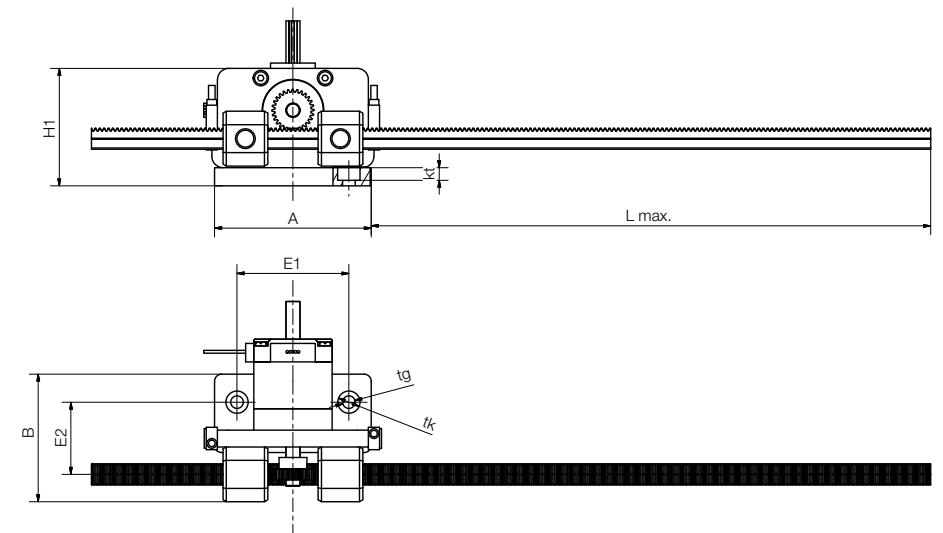
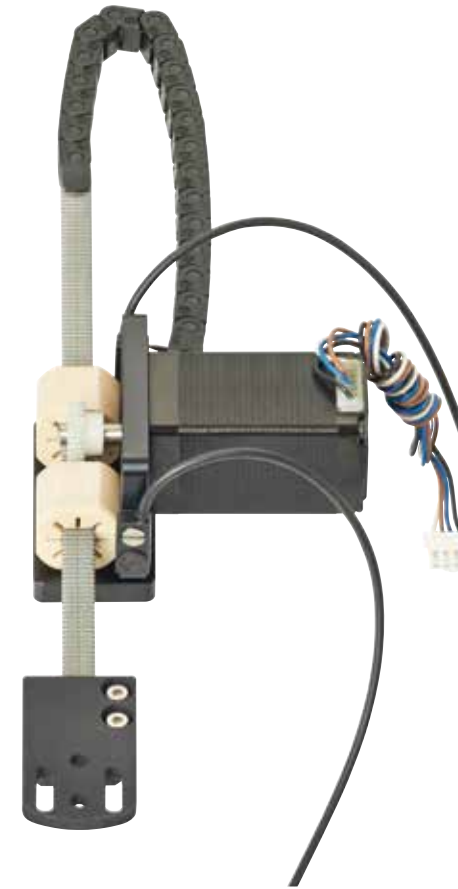

### Dimensions [mm]

| Part No.                    | F   | v     | L    | A  | H1 | E1 | E2 | B  | tg  | tk | kt  | Q   | D2 |
|-----------------------------|-----|-------|------|----|----|----|----|----|-----|----|-----|-----|----|
|                             | [N] | [m/s] | max. |    |    |    |    |    |     |    |     |     |    |
| GRQ-10-A-56-120-11-L-01-000 | 5   | 0.7   | 200  | 56 | 42 | 40 | 26 | 46 | 4.5 | 8  | 4.5 | 7.5 | 22 |





- Made from aluminium and plastic
- Ideal for linear robots
- Direct rack drive
- Torsionally rigid due to drylin® AWMR aluminium hollow shafts
- Lubrication-free and maintenance-free due to drylin® R liners

### Typical application areas:

- Handling
- Sprue pickers
- Room linear robots
- Lifting equipment
- Lab automation

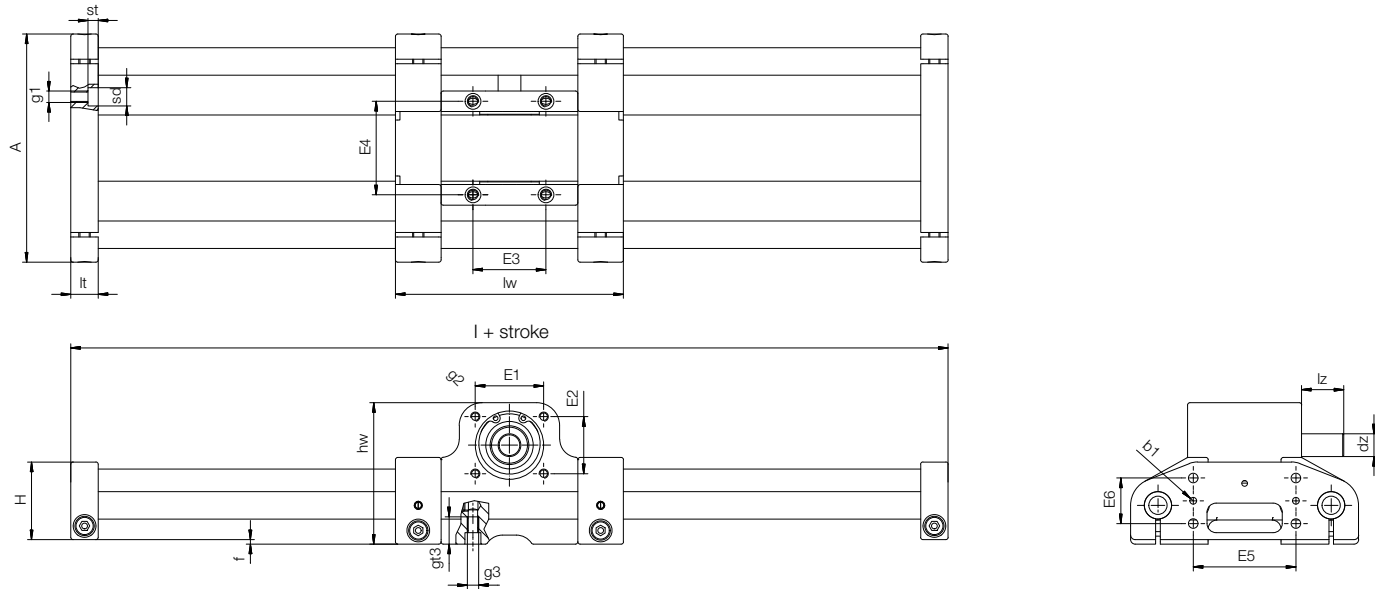

### Technical data

| Part No.             | Max. stroke length [mm] | Transmission [mm/rev] | Tooth profile | Weight without stroke [kg] | Max. static load capacity axial [N] |
|----------------------|-------------------------|-----------------------|---------------|----------------------------|-------------------------------------|
| GRR-1280             | 750                     | 72.26                 | Module 1      | 0.86                       | 50                                  |
| GRR-20120 <b>New</b> | 1,000                   | 72.26                 | Module 1      | 1.62                       | 75                                  |

### Dimensions [mm]

| Part No.             | L   | A   | H  | lw  | hw | lz | dz | f | lt | E1 | E2 | g2    |
|----------------------|-----|-----|----|-----|----|----|----|---|----|----|----|-------|
| GRR-1280             | 124 | 100 | 34 | 100 | 62 | 18 | 10 | 2 | 12 | 30 | 25 | M4-10 |
| GRR-20120 <b>New</b> | 202 | 150 | 50 | 172 | 78 | 18 | 10 | 2 | 15 | 30 | 25 | M4-10 |

| Part No.             | E3  | E4 | g3 | gt3 | E5 | E6 | g1 | sd | st  | b1 | sd3 | st3 | D  |
|----------------------|-----|----|----|-----|----|----|----|----|-----|----|-----|-----|----|
| GRR-1280             | 32  | 41 | M5 | 12  | 45 | 20 | M5 | 8  | 4.5 | 3  | -   | -   | -  |
| GRR-20120 <b>New</b> | 147 | 80 | M8 | -   | 50 | 20 | M5 | 8  | 4.5 | 3  | 11  | 6.6 | 20 |



- Fixed drive unit
- Hard-anodised aluminium axis profile
- Lightweight
- Max. stroke 1,000mm
- Max. axial load 50N
- Permissible load for carriage  $M_{y\max}$ : 15Nm

### Order key

Cantilever axis with ball bearings

## ZAW-1040-02-S-150-L-500

| Cantilever axis | Installation size | Version | Design | Carriage length [mm] | Drive shaft | Stroke length |
|-----------------|-------------------|---------|--------|----------------------|-------------|---------------|
|                 |                   |         |        |                      |             |               |

### Options:

- Design**  
S: Standard
- Drive shaft**  
L: Drive pin left  
R: Drive pin right  
L/R: Drive pin, both sides

**Stroke length**  
Max. 1,000mm

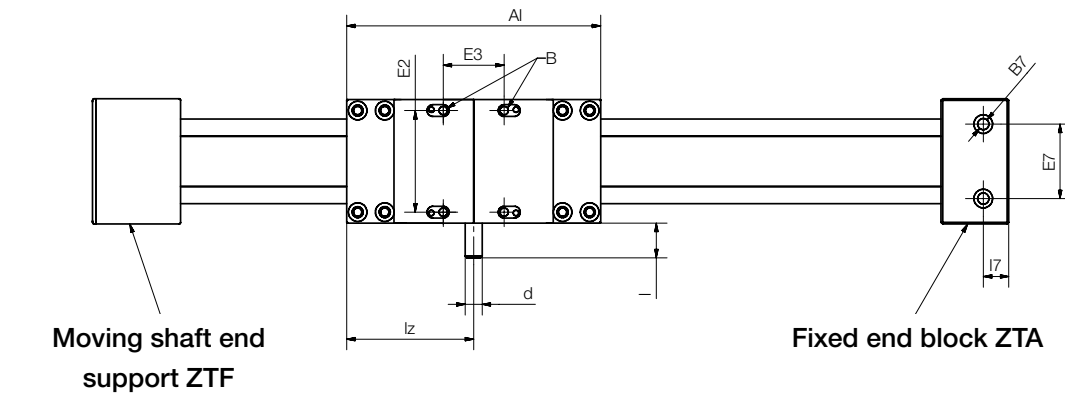
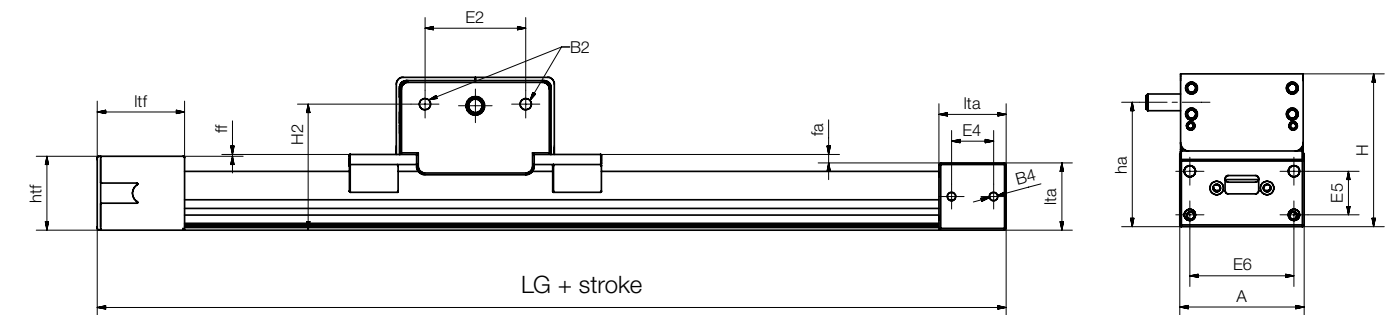
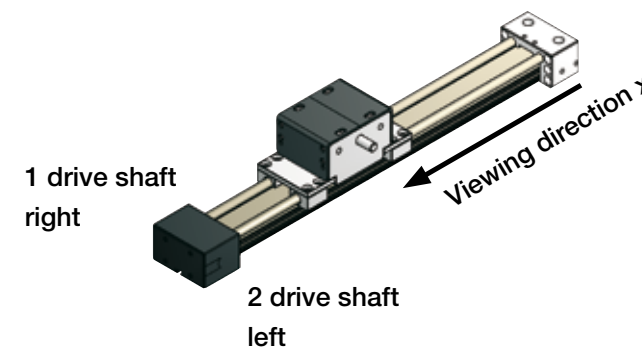

### Dimensions [mm]

| Part No. | A    | H  | H2 | LG  | Al   | ha   | d  | l  | l7 | lz | E2    | E3    |
|----------|------|----|----|-----|------|------|----|----|----|----|-------|-------|
| ZAW-1040 | -0.3 | 91 | 75 | 242 | ±0.3 | ±0.1 | h9 | +1 | 15 | 75 | ±0.15 | ±0.15 |

| Part No.                       | B    | B2 | htf | ltf  | ff   | fa | lta  | E4    | B4    | B7 | E5 | E6 | E7 |
|--------------------------------|------|----|-----|------|------|----|------|-------|-------|----|----|----|----|
| Connecting dimensions ZAW-1040 | -0.3 | M8 | 44  | ±0.3 | ±0.1 | h9 | ±0.1 | ±0.15 | ±0.15 | M6 | M6 | 26 | 62 |

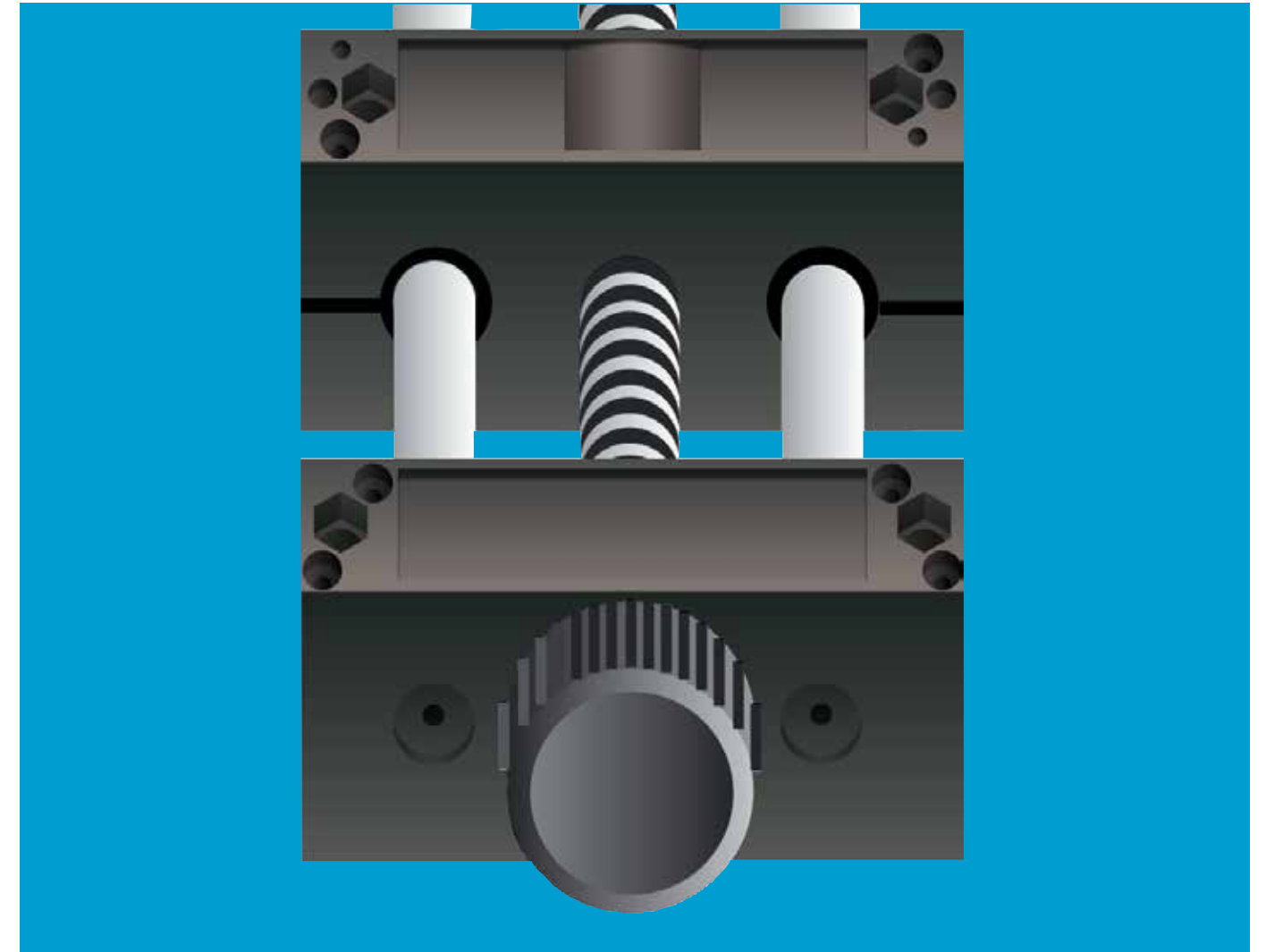
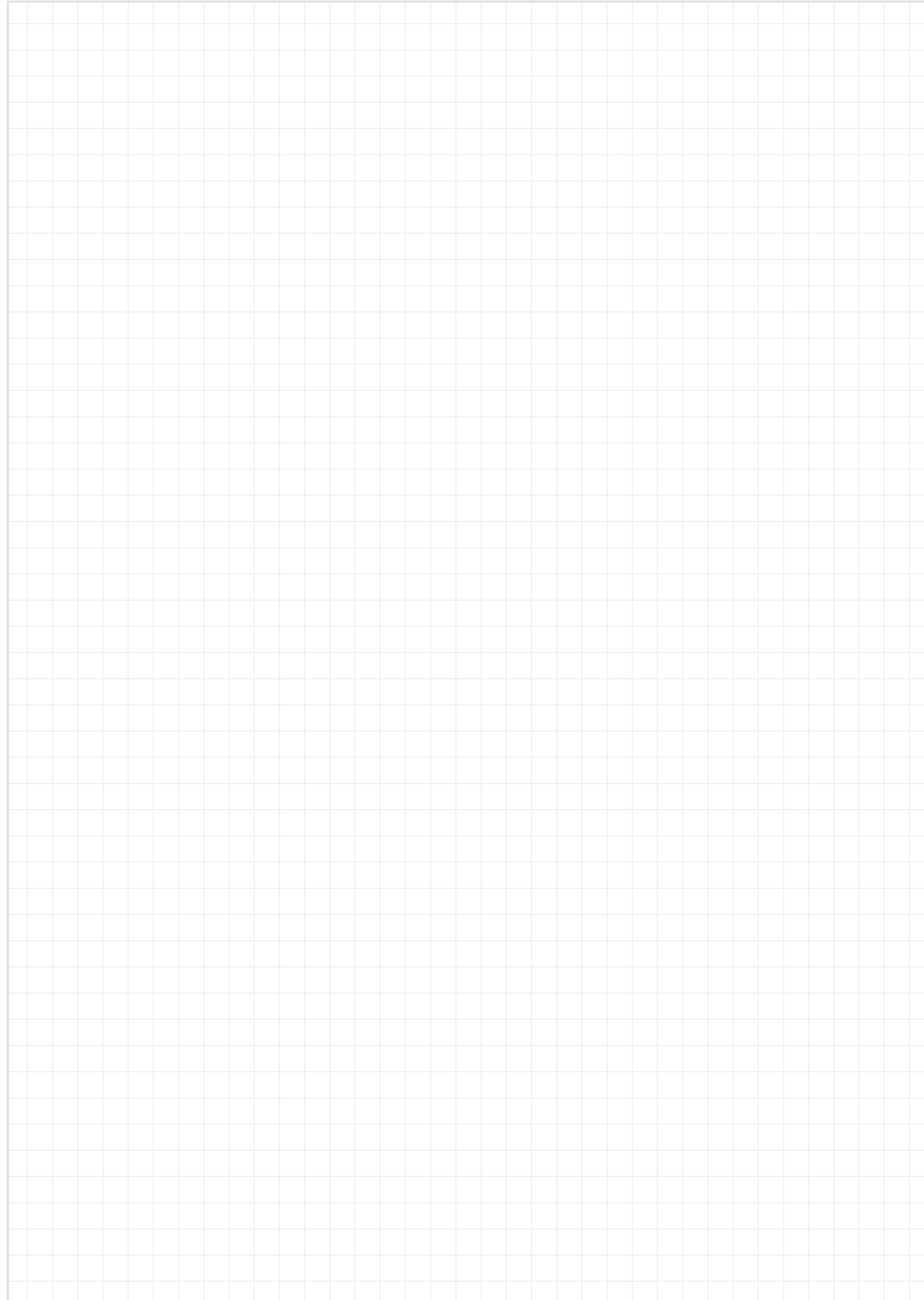

## drylin® general drive technology - econ entry-level series

Cost-effective linear modules

Drive: Trapezoidal and high helix lead screws,  
toothed belt

Lightweight construction

Corrosion-resistant

For positioning and adjusting tasks



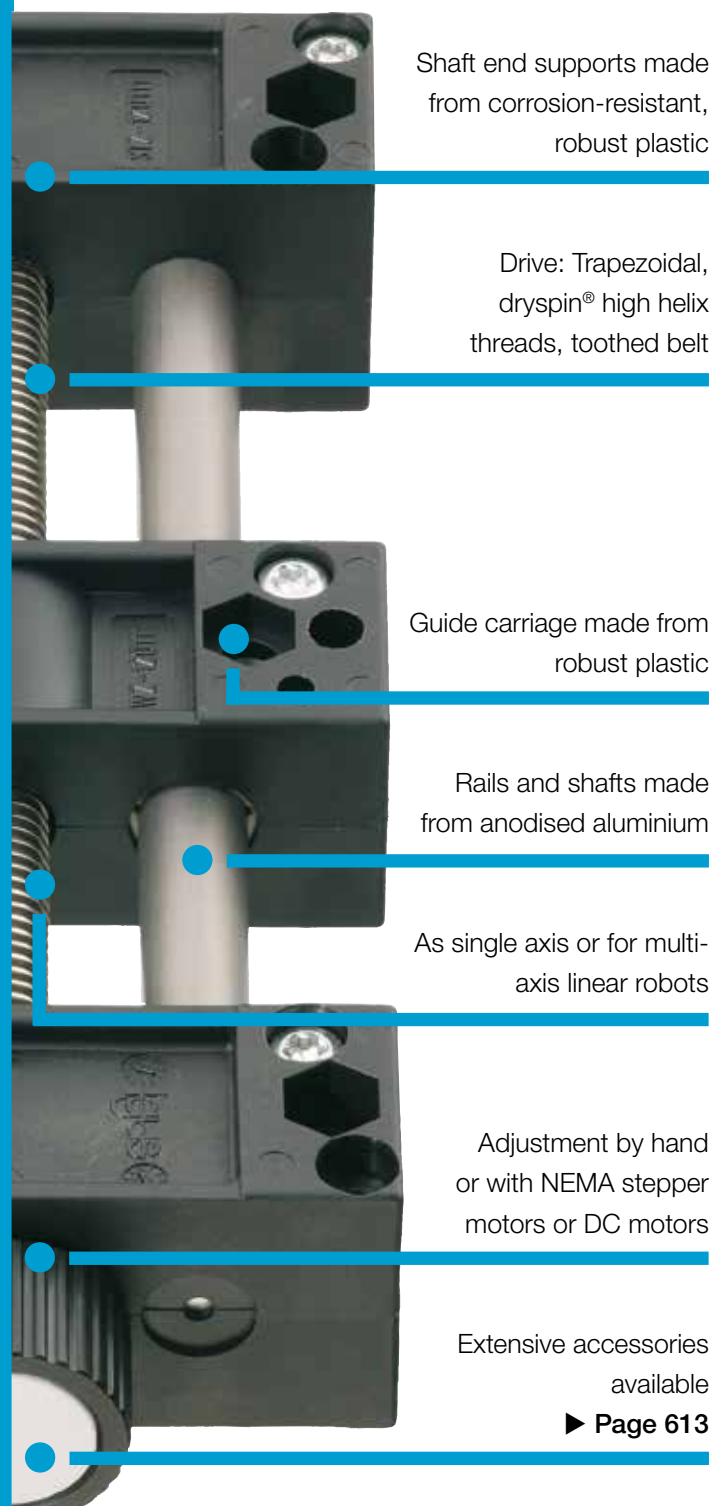

Shaft end supports made from corrosion-resistant, robust plastic

Drive: Trapezoidal, dryspin® high helix threads, toothed belt

Guide carriage made from robust plastic

Rails and shafts made from anodised aluminium

As single axis or for multi-axis linear robots

Adjustment by hand or with NEMA stepper motors or DC motors

Extensive accessories available  
▶ Page 613

## Lubrication-free linear modules - drylin® econ

With econ, igus® defines the cost-effective maintenance-free entry-level models of the drylin® linear axes. There are suitable entry-level models in almost every product line and installation size, either with a lead screw or toothed belt. The econ series is characterised by cost-effective components produced via injection moulding, anodised aluminium profiles and fast assembly. drylin® econ models are configured and delivered so that they are ready to install and are thus the perfect alternative to complex in-house solutions for simple adjustment tasks.

- Lightweight construction thanks to plastic-aluminium combination
- Designed for a fast assembly
- Cost-effective thanks to injection moulding and clear anodising

### Typical application areas

- Gripper technology
- Format adjustments
- Camera adjustment

 **Available in 3-8 days**  
Detailed information about delivery time online.

 **Price breaks online**  
No minimum order value. No minimum order quantity

 **Carriage lengths: 26-45mm**  
**Stroke length max. 500mm**

 **Product finder**  
▶ [www.igus.eu/shtp-productfinder](http://www.igus.eu/shtp-productfinder)



### drylin® econ SLWP linear module - robust in 2 sizes

- Flat and torsion-resistant due to drylin® W double shaft profiles
  - Lead screw with self-locking trapezoidal or metric thread
  - Fast adjustment due to dryspin® high helix thread
- ▶ Page 604



### drylin® econ SHTP linear module - flexible in 3 sizes

- Lead screws made from aluminium, carbon, steel, stainless steel
  - Carriage with integrated lead screw nuts and drylin® R liner
  - With trapezoidal or high helix thread
- ▶ Page 606



### drylin® econ SLN miniature module - small and fast

- Slim, narrow design
  - Lead screw mounted on plain bearings with metric thread or dryspin® high helix thread
  - Feed rate of up to 25mm per rotation
- ▶ Page 610

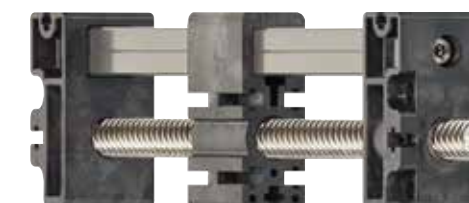

### drylin® econ SLTP linear system - savings thanks to injection moulding

- Developed with 3D printing, produced cost-effectively thanks to injection moulding
  - Very fast assembly due to few components
  - Carriage with a lot of fastening options
- ▶ Page 605

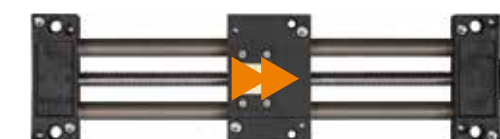

### drylin® econ SHTP-FF linear module - Fast-Forward

- With quick-release mechanism
  - For fast adjustment
  - Self-locking
  - Variable stroke lengths
- ▶ Page 609



### drylin® econ ZLW toothed belt axis - light and fast

- Lightweight due to use of plastic and aluminium
  - Variable attachment by means of slot nuts and clamping elements
  - Individual stroke lengths (sizes 0630 to 500mm, 1040 to 1,000mm)
- ▶ Page 611

## The SLW entry-level model



- Based on drylin® W profile guides
- Clear anodised guide rails
- Torsion-resistant double shaft systems
- Self-locking due to metric or trapezoidal thread
- Fast operation without self-locking due to dryspin® high helix thread
- Accessories available

► Page 613



Order key

Order example

SLWP-0630-E

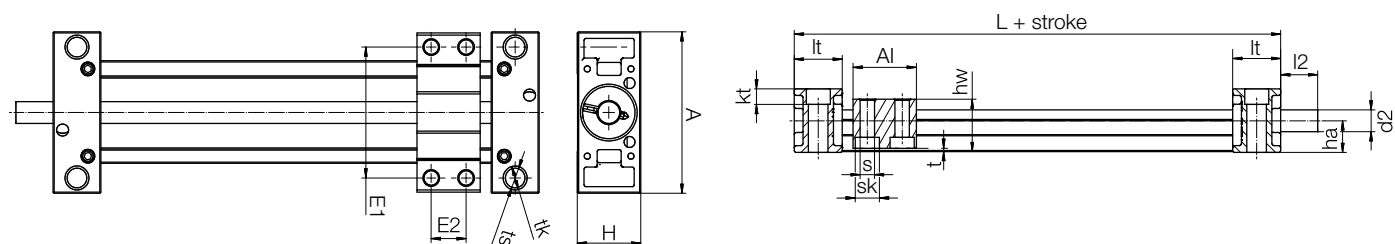

## Technical data

| Part No.    | Max. stroke length<br>[mm] | Weight<br>[kg] | additional<br>(per 100mm)<br>[kg] | Max. stat. load capacity |            |
|-------------|----------------------------|----------------|-----------------------------------|--------------------------|------------|
|             |                            |                |                                   | axial [N]                | radial [N] |
| SLWP-0630-E | 300                        | 0.15           | 0.08                              | 50                       | 50         |
| SLWP-1040-E | 500                        | 0.30           | 0.10                              | 50                       | 50         |

## Dimensions [mm]

| Part No.    | A    | Al   | H  | E1   | E2   | E3    | l   | hw   | f   | lt   | tk | ts  |
|-------------|------|------|----|------|------|-------|-----|------|-----|------|----|-----|
|             | -0.3 | -0.3 |    | ±0.2 | ±0.2 | ±0.15 |     |      |     | ±0.1 |    |     |
| SLWP-0630-E | 54   | 60   | 20 | 40   | 45   | 51    | 100 | 18.0 | 1.5 | 20   | 11 | 6.6 |
| SLWP-1040-E | 74   | 29   | 29 | 60   | 16   | -     | 73  | 23.5 | 1.5 | 22   | 11 | 6.8 |

| Part No.    | kt   | Øs  | sk     | d   | T       | l2 | d2                      | ha   |
|-------------|------|-----|--------|-----|---------|----|-------------------------|------|
|             | ±0.1 |     |        |     |         |    | Standard                |      |
| SLWP-0630-E | 8.0  | 5.0 | 6Kt M4 | 5.0 | Tr8x1.5 | 15 | Tr8x1.5 <sup>160)</sup> | 9.5  |
| SLWP-1040-E | 9.0  | 6.3 | 6Kt M6 | 7.5 | Tr10x2  | 17 | Tr10x2 <sup>161)</sup>  | 14.5 |

<sup>160)</sup> Alternative: M8, Tr8x1,5, Ds8x10, Ds8x15

<sup>161)</sup> Alternative: Tr10x2, Tr10x3, Ds10x12, Ds10x25, Ds10x50

## The SLT entry-level model



- Extremely cost-effective
- Torque-resistant due to AWMQ aluminium square profile
- Flexible design
- Left or right-hand lead screw option
- Carriage with many connection options



Order key

Order example

SLTP-1012-E

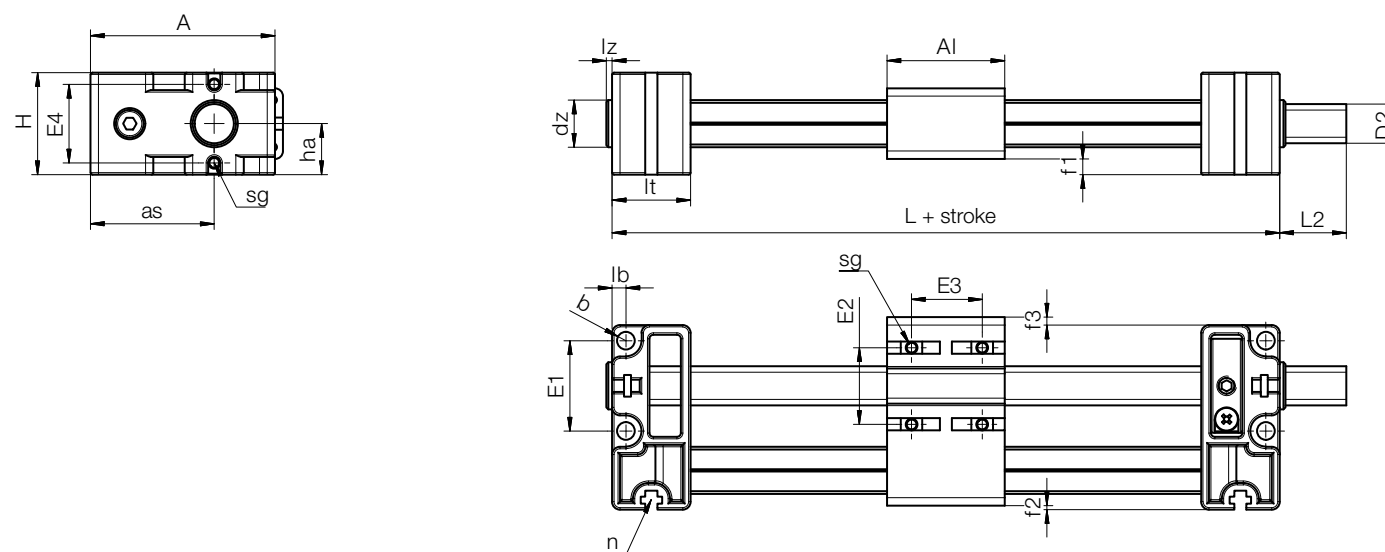

## Technical data

| Part No.    | Max. stroke length<br>[mm] | Weight<br>[kg] | additional<br>(per 100mm)<br>[kg] | Max. stat. load capacity |            | Max. Rotational speed<br>[rpm] | Max. Speed<br>[m/min] |
|-------------|----------------------------|----------------|-----------------------------------|--------------------------|------------|--------------------------------|-----------------------|
|             |                            |                |                                   | axial [N]                | radial [N] |                                |                       |
| SLTP-1012-E | 300                        | 0.147          | 0.081                             | 50                       | 100        | 250                            | 0.5                   |

## Dimensions [mm]

| Part No.    | A  | H  | L + stroke | Al | L2 | D2 | E1 | E2   | E3       | E4 | T <sup>152)</sup> |
|-------------|----|----|------------|----|----|----|----|------|----------|----|-------------------|
| SLTP-1012-E | 47 | 26 | 70         | 30 | 17 | 10 | 23 | 19.5 | 8.5-24.5 | 20 | Tr10x2            |

| Part No.    | lt | dz    | lz  | b   | lb  | sg <sup>153)</sup> | ha | as   | n  | f1 | f2 | f3 |
|-------------|----|-------|-----|-----|-----|--------------------|----|------|----|----|----|----|
|             |    | -0.05 |     |     |     | (DIN562)           |    |      |    |    |    |    |
| SLTP-1012-E | 20 | 12    | 1.5 | 4.5 | 3.5 | M3                 | 13 | 31.5 | M3 | 4  | 1  | 2  |

<sup>152)</sup> Alternative: Tr10x3, Tr10x4P2, Ds10x12, Ds10x25, Ds10x50

<sup>153)</sup> 6 pieces of M3-DIN562 screws included in delivery



The SHT miniature version



- Miniature version
  - Lightweight
  - Cost-effective
  - Corrosion-resistant
  - Carriages and shaft end supports made from high-performance polymers
  - Accessories available
- Page 613



Order example

SHTP-01-06-AWM

SHT polymer

Design

Dimension

Shaft material

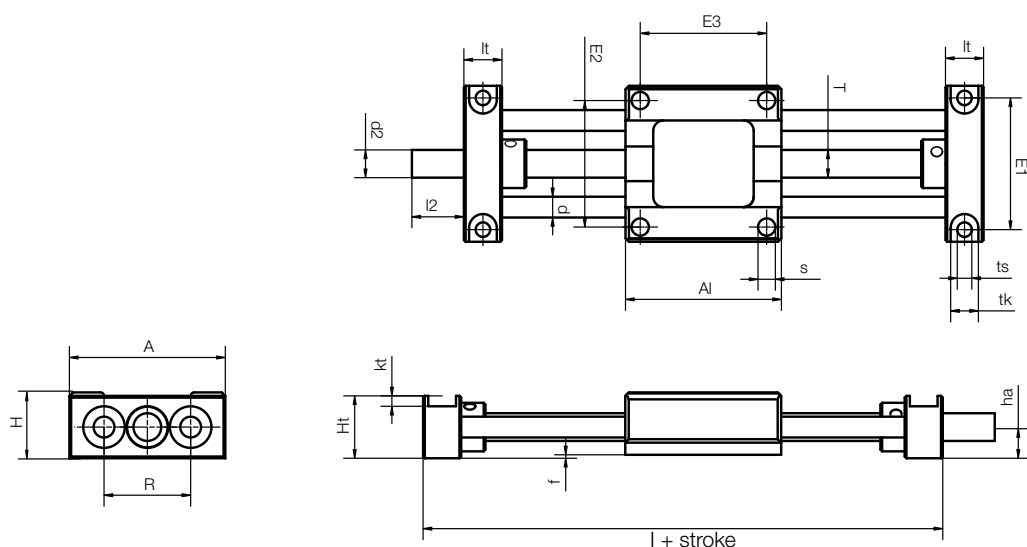

Technical data

| Part No.       | Max. stroke length [mm] | Aluminium shaft |                             | Max. static load capacity |            | More information                                    |
|----------------|-------------------------|-----------------|-----------------------------|---------------------------|------------|---|
|                |                         | Weight [kg]     | additional [kg] (per 100mm) | axial [N]                 | radial [N] |   |
| SHTP-01-06-AWM | 300                     | 0.11            | 0.06                        | 50                        | 50         | Carriage, square, with 4 symmetrical mounting holes |

Dimensions [mm]

| Part No.       | A  | Al | H  | Ht | E1 | E2   | E3   | I  | R  | f | kt | lt | tk | ts  |
|----------------|----|----|----|----|----|------|------|----|----|---|----|----|----|-----|
| SHTP-01-06-AWM | 45 | 45 | 19 | 18 | 38 | 36.5 | 36.5 | 67 | 25 | 1 | 3  | 11 | 8  | 4.2 |

| Part No.       | Øs  | d | T  | I2 | d2 <sup>99)</sup> | ha |
|----------------|-----|---|----|----|-------------------|----|
| SHTP-01-06-AWM | 5.1 | 6 | M8 | 15 | M8                | 9  |

<sup>99)</sup> Lead screw end unmachined (standard)

SHTP - the lightweight SHT entry-level model



- Very light
  - Low-profile design
  - Ideal for multi-carriage solutions
  - Accessories available
- Page 613



Order example

SHTP-01-10

SHT polymer

Design

Dimension

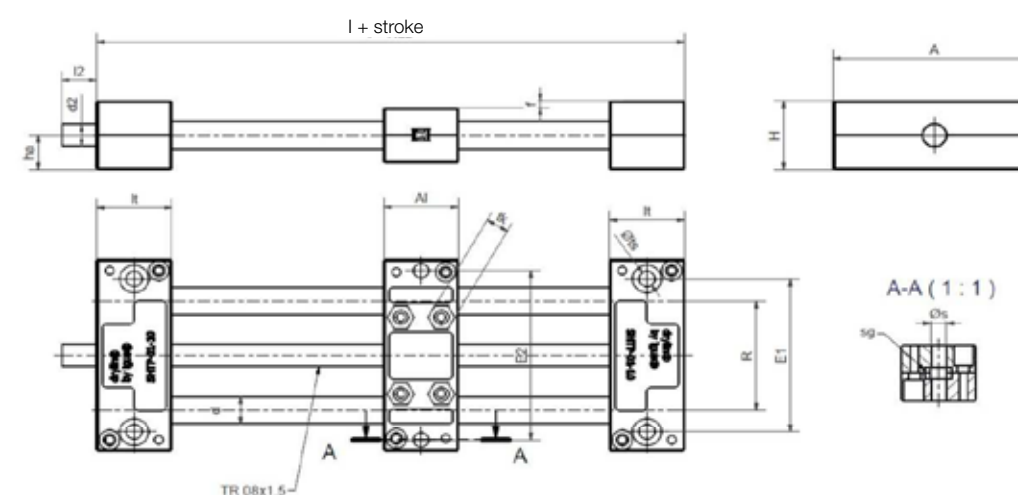

Technical data

| Part No.   | Max. stroke length [mm] | Aluminium shaft |                             | More information                                   |
|------------|-------------------------|-----------------|-----------------------------|--|
|            |                         | Weight [kg]     | additional [kg] (per 100mm) |  |
| SHTP-01-10 | 350                     | 0.2             | 0.08                        | Drive nut and linear bearings made from iglidur® J |

Dimensions [mm]

| Part No.   | A  | Al | H  | E1 | E2 | I  | R  | f   | lt   | tk | ts    |
|------------|----|----|----|----|----|----|----|-----|------|----|-------|
| SHTP-01-10 | 70 | 26 | 25 | 56 | 62 | 78 | 40 | 2.5 | ±0.1 | 8  | +0.15 |

| Part No.   | Øs  | sg | d  | T        | I2 | d2 <sup>99)</sup> | ha   | Max. static load capacity |            |
|------------|-----|----|----|----------|----|-------------------|------|---------------------------|------------|
|            |     |    |    |          |    |                   |      | axial [N]                 | radial [N] |
| SHTP-01-10 | 5.2 | M5 | 10 | Tr08x1.5 | 15 | Tr08x1.5          | 12.5 | 100                       | 400        |

<sup>99)</sup> Lead screw end unmachined (standard)

SHTP - the cost-effective SHT version

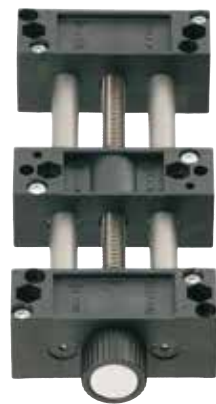

- Solid polymer design
- Lightweight
- Cost-effective
- Corrosion-resistant
- Accessories available
- ▶ Page 613
- Available with motor



Order example

SHTP-01-12-AWM

SHT polymer | Design | Dimension | Shaft material

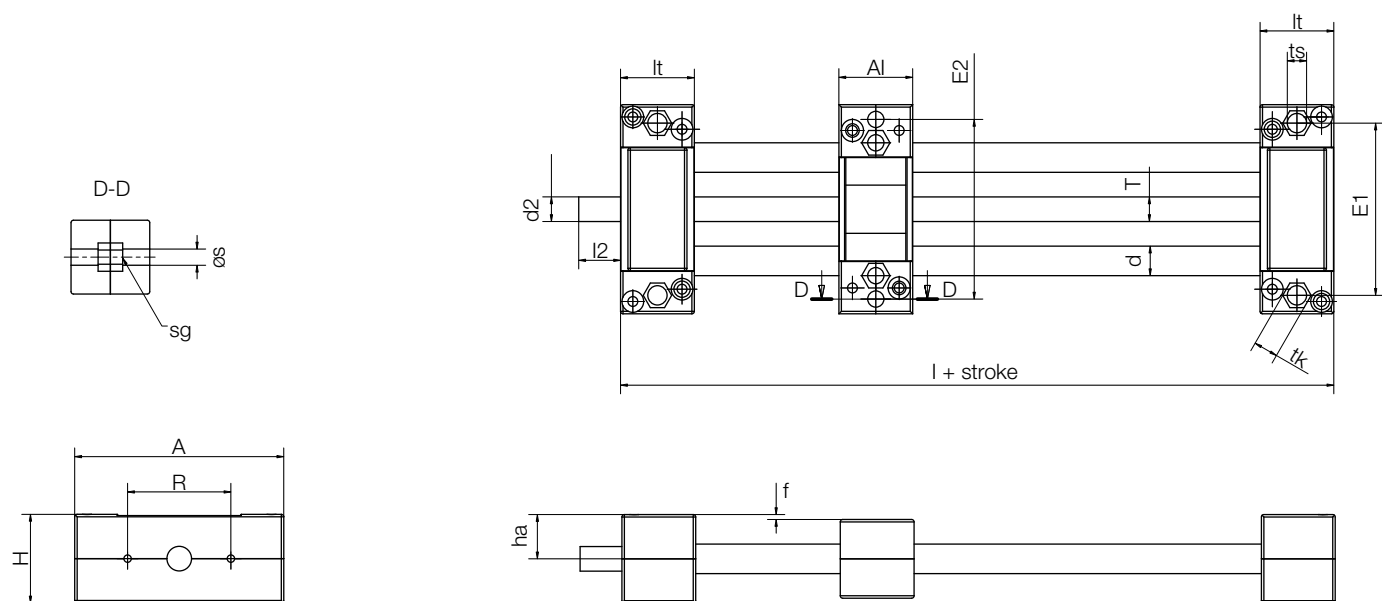

Technical data

| Part No.   | Max. stroke length [mm] | Aluminium shaft |                             | More information                                   |
|------------|-------------------------|-----------------|-----------------------------|--|
|            |                         | Weight [kg]     | additional [kg] (per 100mm) |  |
| SHTP-01-12 | 500                     | 0.35            | 0.11                        | Drive nut and linear bearings made from iglidur® J |
| SHTP-02-12 | 500                     | 0.35            | 0.11                        | Bearing and nut integrated into the carriage       |

Dimensions [mm]

| Part No.   | A  | Al | H  | E1 | E2 | I  | R  | f | lt         | tk | ts           |
|------------|----|----|----|----|----|----|----|---|------------|----|--------------|
| SHTP-01-12 | 85 | 30 | 36 | 70 | 73 | 90 | 42 | 2 | ±0.1<br>30 | 10 | +0.15<br>6.0 |
| SHTP-02-12 | 85 | 30 | 36 | 70 | 73 | 90 | 42 | 2 | 30         | 10 | 6.0          |

| Part No.   | Øs  | sg | d  | T      | l2 | d2 <sup>99)</sup> | ha | Max. static load capacity |            |
|------------|-----|----|----|--------|----|-------------------|----|---------------------------|------------|
|            |     |    |    |        |    |                   |    | axial [N]                 | radial [N] |
| SHTP-01-12 | 6.3 | M6 | 12 | Tr10x2 | 17 | Tr10x2            | 18 | 200                       | 400        |
| SHTP-02-12 | 6.3 | M6 | 12 | Tr10x2 | 17 | Tr10x2            | 18 | 200                       | 400        |

<sup>99)</sup> Lead screw end unmachined (standard)

With "Fast Forward" quick release mechanism

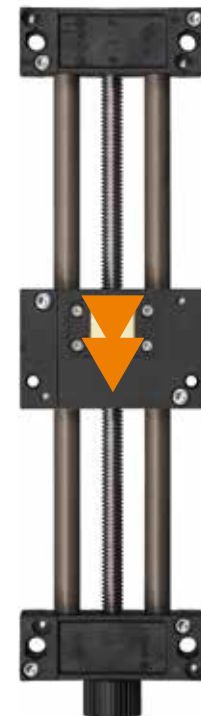

- Light solid polymer model
- For fast format adjustments
- Self-locking
- Variable stroke length
- Only recommended for horizontal applications
- Max. stat. axial load 200N
- Max. dynamic. axial load 50N
- Accessories available
- ▶ Page 613



Order example

SHTP-01-12-AWM-FF

SHT polymer | Design | Dimension | Shaft material | Fast Forward

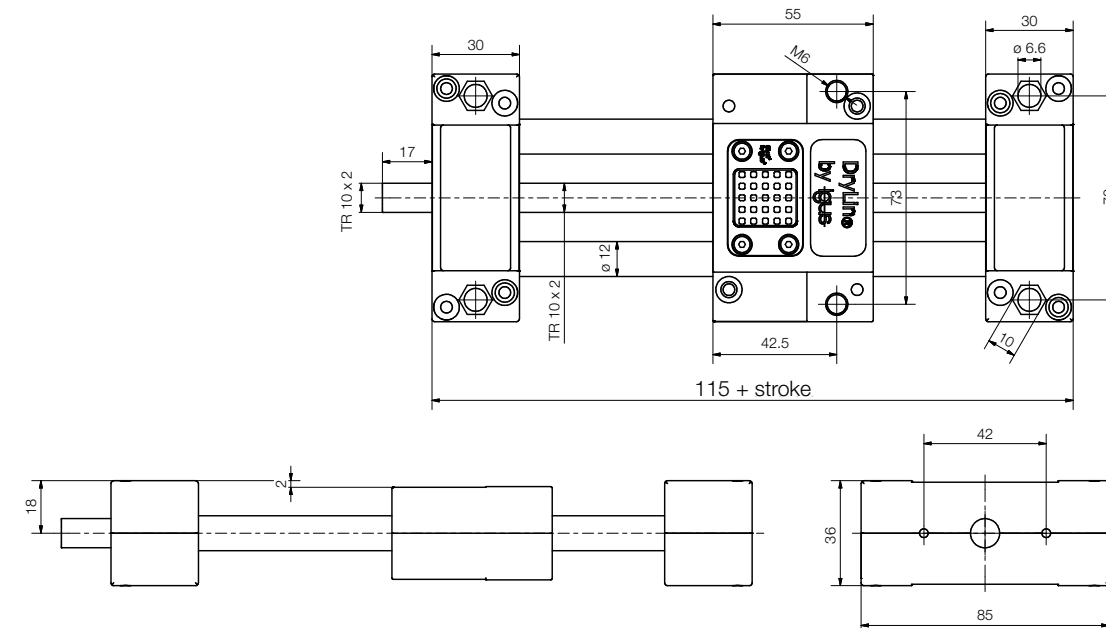

Technical data

| Part No.                          | Max. stroke length [mm] | Weight [kg] | Additional weight (per 100mm) |
|-----------------------------------|-------------------------|-------------|-------------------------------|
| SHTP-01-12-AWM-FF <sup>100)</sup> | 500                     | 0.35        | 0.11                          |

<sup>100)</sup> Liners and lead screw nuts made from iglidur® J

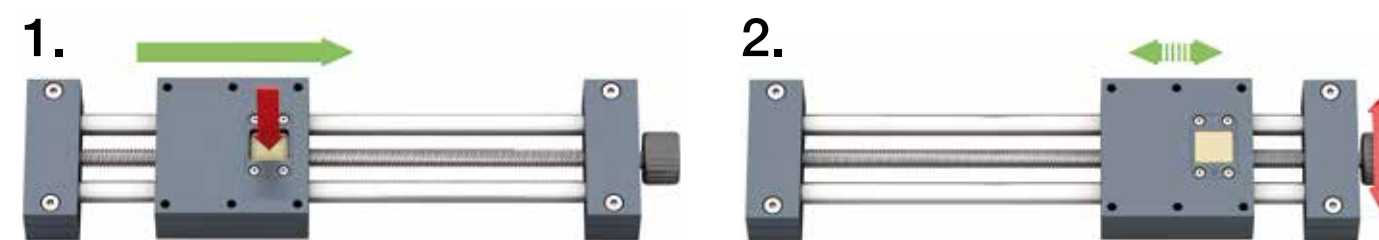

press > disengage > move manually > click into place > fine-tuning

Miniature linear module, basic version



- Single parts made from aluminium and plastic
- Entry-level model
- Lead screw with plain bearing support
- Retrofitting possible
- Accessories available
- ▶ Page 613
- Available with motor

Order key



Order example

**SLN-27-03-0008**

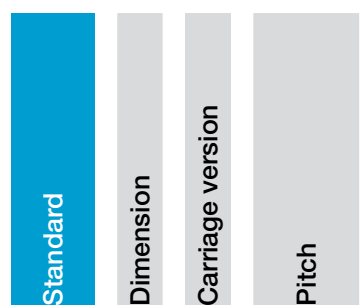

Options:  
Carriage version  
03: Basic

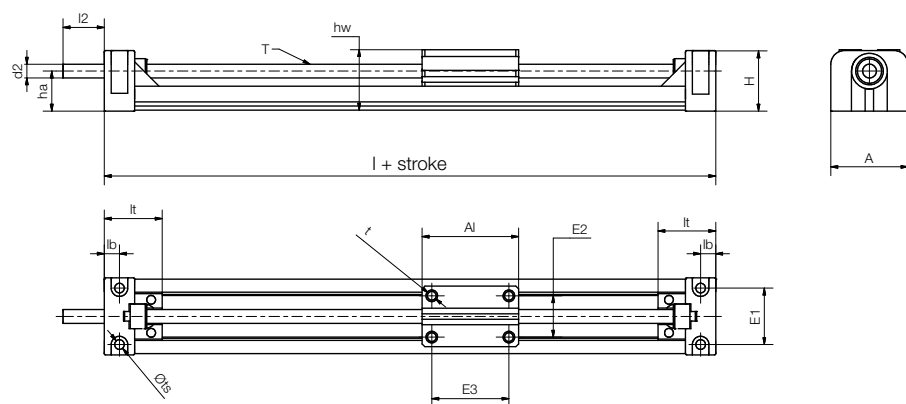

Technical data

| Part No.       | Max. stroke length | Weight | addit.      | Max. static load capacity | Max. speed | Max. drive torque |
|----------------|--------------------|--------|-------------|---------------------------|------------|-------------------|
|                | [mm]               | [kg]   | [kg]        | axial                     | radial     | [rpm]             |
|                |                    |        | (per 100mm) | [N]                       | [N]        | [Nm]              |
| SLN-27-03-0008 | 250                | 0.06   | 0.04        | 10                        | 40         | 0.10              |
| SLN-27-03-0025 | 250                | 0.06   | 0.04        | 10                        | 40         | 0.15              |
| SLN-27-03-0051 | 250                | 0.06   | 0.04        | 10                        | 40         | 0.20              |
| SLN-27-03-0127 | 250                | 0.06   | 0.04        | 10                        | 40         | 0.30              |
| SLN-27-03-0254 | 250                | 0.06   | 0.04        | 10                        | 40         | 0.40              |

Dimensions [mm]

| Part No.       | A    | Al   | H    | E1    | E2    | E3    | E11 <sup>102)</sup> | I  | hw   | lt   | lb  | ts  | t   | T         | d2 <sup>98)</sup> | I2 | ha   |
|----------------|------|------|------|-------|-------|-------|---------------------|----|------|------|-----|-----|-----|-----------|-------------------|----|------|
|                | ±0.2 | -0.1 | ±0.2 | ±0.15 | ±0.15 | ±0.15 |                     |    | ±0.2 | ±0.2 |     |     |     |           |                   |    |      |
| SLN-27-03-0008 | 28   | 35   | 22   | 20.5  | 15    | 28    | 15                  | 77 | 22   | 21   | 5.5 | 3.5 | 3.2 | M5        | 4                 | 15 | 14.5 |
| SLN-27-03-0025 | 28   | 35   | 22   | 20.5  | 15    | 28    | 15                  | 77 | 22   | 21   | 5.5 | 3.5 | 3.2 | 6.35x2.54 | 5                 | 15 | 14.5 |
| SLN-27-03-0051 | 28   | 35   | 22   | 20.5  | 15    | 28    | 15                  | 77 | 22   | 21   | 5.5 | 3.5 | 3.2 | 6.35x5.08 | 5                 | 15 | 14.5 |
| SLN-27-03-0127 | 28   | 35   | 22   | 20.5  | 15    | 28    | 15                  | 77 | 22   | 21   | 5.5 | 3.5 | 3.2 | 6.35x12.7 | 5                 | 15 | 14.5 |
| SLN-27-03-0254 | 28   | 35   | 22   | 20.5  | 15    | 28    | 15                  | 77 | 22   | 21   | 5.5 | 3.5 | 3.2 | 6.35x25.4 | 5                 | 15 | 14.5 |

<sup>102)</sup>The dimension E11 can only be found in conjunction with the igus® motor connection

<sup>98)</sup> Thread/remaining thread visible

With manual clamp (optional): Part No. SLN-27-HK-...

Linear axes with toothed belt



- Fast positioning of small loads
- Quiet operation and flat design
- Drive pin on one or both sides
- Plastic linear carriage
- Lightweight due to combination of plastic and aluminium
- Technical data
- ▶ Page 578

Order key



Order example

**ZLW-0630-02-E**



Options:  
Version  
02: With deep groove ball bearings  
Design  
E: econ series (0630/1040)

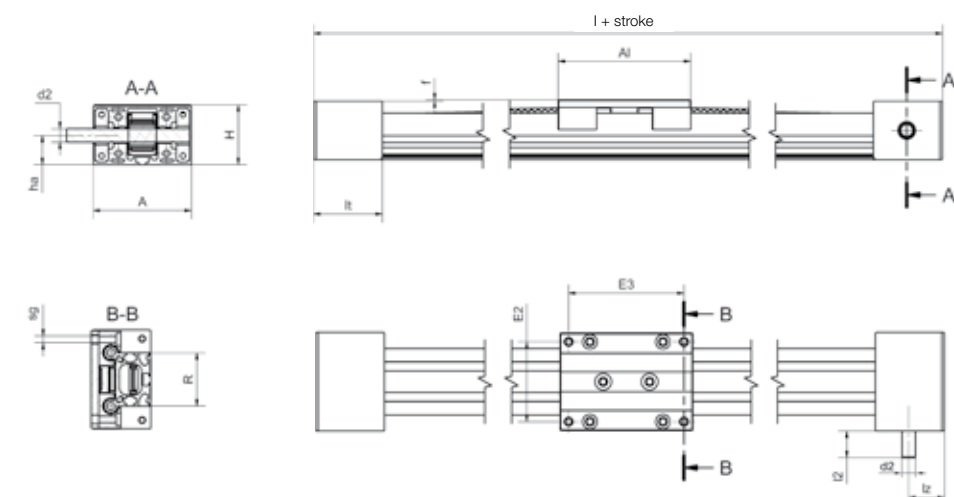

Dimensions [mm]

| Part No.    | A    | Al  | H  | E2    | E3    | I   | R     | f | lt   | sg | ha | hc   | Iz   | I2 | d2 |
|-------------|------|-----|----|-------|-------|-----|-------|---|------|----|----|------|------|----|----|
|             | -0.3 |     |    | ±0.15 | ±0.15 |     | ±0.15 |   | ±0.3 |    |    |      |      |    | h9 |
| ZLW-0630-02 | 54   | 60  | 31 | 45    | 51    | 144 | 30    | 3 | 42   | M4 | 14 | 22.5 | 20.5 | 20 | 8  |
| ZLW-1040-02 | 74   | 100 | 44 | 60    | 87    | 204 | 40    | 1 | 52   | M6 | 22 | 22.5 | 27   | 20 | 10 |

Connecting dimensions [mm]

| Part No.                    | X        | E    | AP   | Lp | dp  | n   | nb  | nw  | nh   | T1    | T2    | d   |
|-----------------------------|----------|------|------|----|-----|-----|-----|-----|------|-------|-------|-----|
|                             |          | ±0.2 | -1.0 |    |     |     |     |     |      | ±0.25 | ±0.25 |     |
| ZLW-0630-02 <sup>109)</sup> | variable | 40   | 52   | 15 | 5.5 | -   | -   | 4.3 | 7    | 20    | 21    | 3.2 |
| ZLW-1040-02                 | variable | 60   | 78   | 40 | 6.4 | 5.2 | 9.5 | 4.3 | 15.5 | 36    | 26.5  | 5.0 |

<sup>109)</sup> Basic version: 6mm square, plastic adapter for pin diameter 10mm included

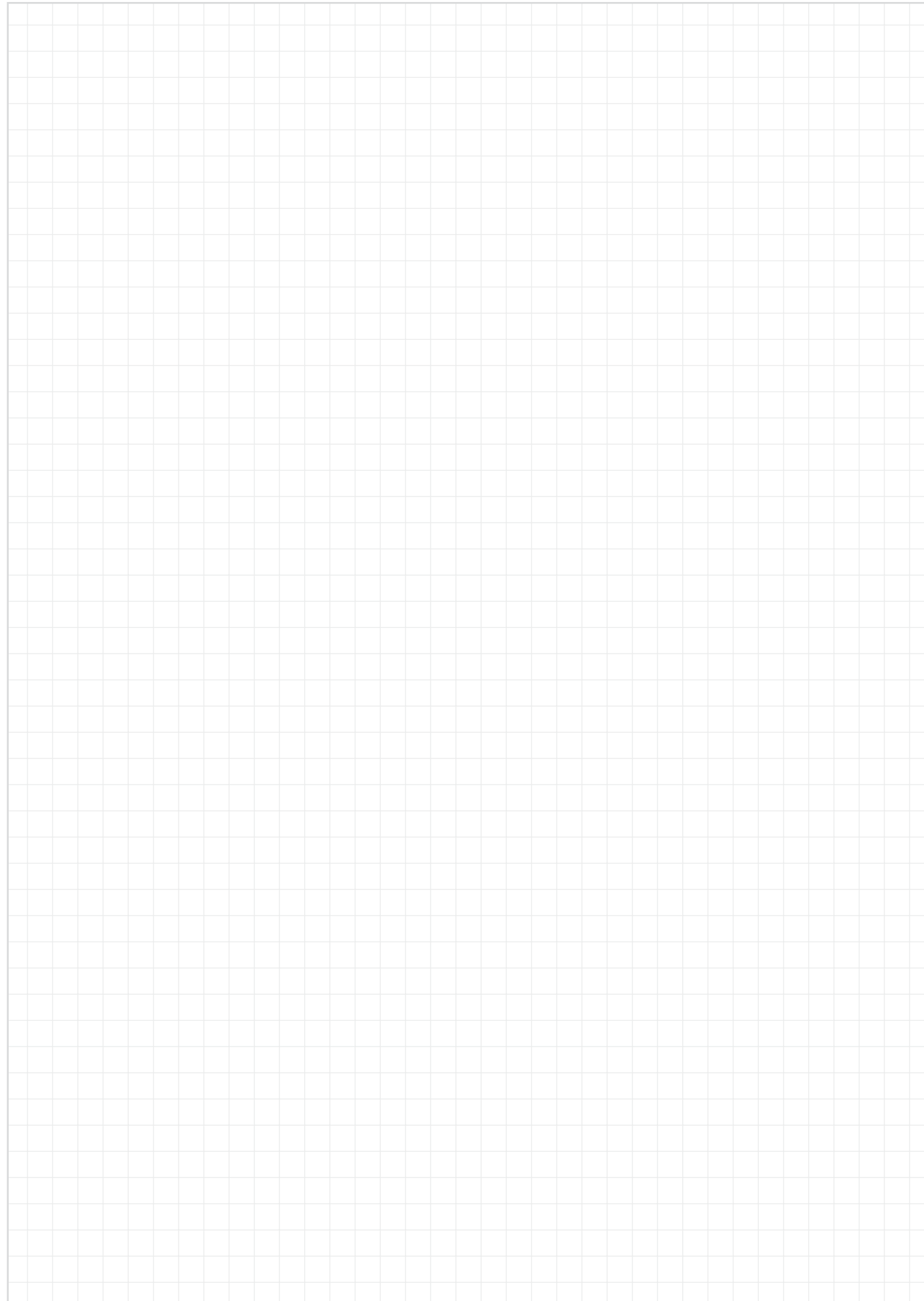

## drylin® accessories - control elements

Accessories for manual positioning and format adjustment

Angular drive

Position indicator

Hand wheels

Control units





Secure, reproduce and turn

## Accessories for drylin® drive technology - manual positioning

An extensive range of accessories is available for many drylin® drive units to perform manual adjustments quickly and conveniently. When directly configuring the linear unit with the order, the units are shipped completely assembled. Any subsequent reconfiguration may result in the lead screw having to be exchanged because the lead screw ends may be too short.

- Fast and precise positioning
- Ergonomic operation
- Provides a mechanical brake

 **Available from stock**  
Detailed information about delivery time online.

 **Price breaks online**  
No minimum order value. No minimum order quantity



Manual operation, manual positioning



### Angular drive

- 360° continuously adjustable
  - Fixing of setting angle with clamp
  - Small flange saves installation space
- Page 616



### Lead screw clamp

- For clamping of the lead screw
  - Provides a mechanical brake to the lead screw
  - Material: polymer housing with aluminium shaft clamp
- Page 620



### Hand wheels

- Rotary knob: Defined standard for complete units
  - Different outer diameters available
  - Different handles available
- Page 621



### Position indicator

- Direct read-out of the carriage position for the lead screw drive
  - Bore reducers included to enable fitting to the entire product
- Page 618



### Adapter plate

- Position indicator and/or lead screw clamp
  - Suitable for linear modules of SHT/SLW/SHTP series
  - Material: plastic igamid® G
- Page 687



### Flex shaft incl. remote control unit

- Optional offset operation of the drylin® linear modules
  - Controls can be positioned independently
  - Available in length 300, 500 and 1,000mm
  - Can be combined with other accessories
- Page 623

Angular drives - flexible positioning

In addition to safety technology aspects, limited operating space requires drylin® drives to be operated with flexibility and ease. We provide a product range of continuously adjustable angular drives for adjustment options from a defined direction. For manual adjustments, the angular drives can also be configured with position indicator, clamp and hand wheel, and are shipped pre-assembled. Angular drives with keyed/grooved shafts are available for motor interfaces with increased torque transfers.



- Double-side shaft output for angular drives WT-3 and WT-4
- For rotary transmissions of 90°
- Configuration with lead screw clamping/position indicator/hand wheel possible
- Position indicator, lead screw clamp and hand wheel available ► **Page 618**

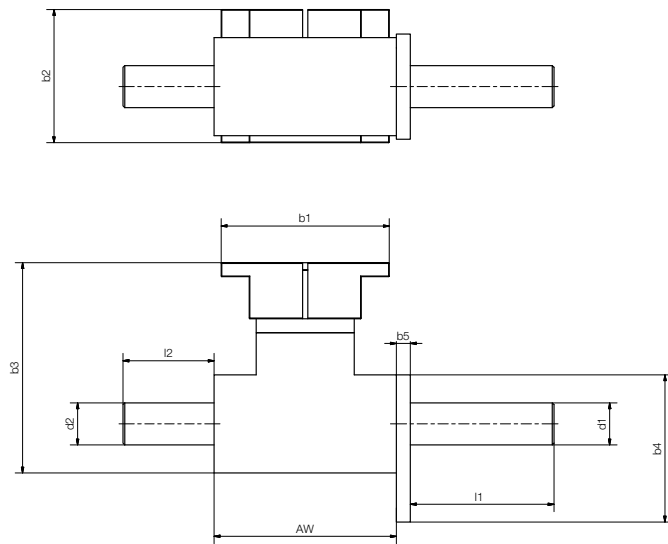

Dimensions [mm]

| Part No.  | M max. [N] | i <sup>105)</sup> | AW | d1 | d2 | l1                | l2 | b1 | b2 | b3 | b4 | b5 |
|-----------|------------|-------------------|----|----|----|-------------------|----|----|----|----|----|----|
| WT-3000-T | 3          | 01:01             | 52 | 12 | 12 | 26 / 41 / 59 / 74 | 26 | 48 | 38 | 60 | 42 | 4  |
| WT-4000-T | 6          | 01:01             | 60 | 14 | 14 | 26 / 47 / 65 / 80 | 26 | 56 | 46 | 83 | 50 | 10 |

<sup>105)</sup> Gear ratio



- Flexible adjusting to your installation with continuously variable adjustment (can be oscillated 360°)
- Max. drive torque 3Nm
- Clamping using set screw
- Ø 12mm h7 output shaft

**i** Depending on the design, an adapter plate is used for connection to the linear system

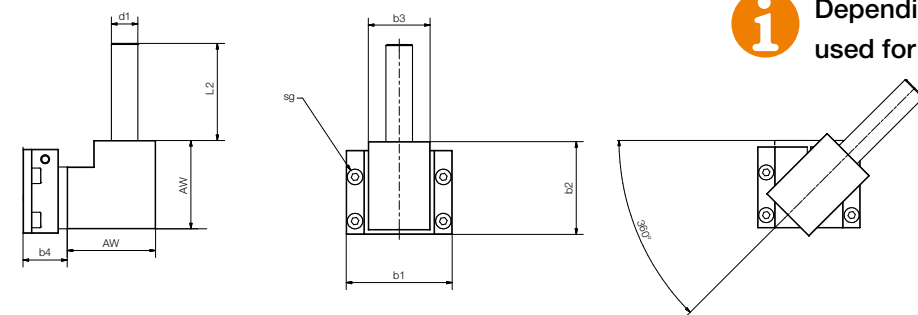

Dimensions [mm]

| Part No.              | i <sup>105)</sup> | AW | b1 | b2 | b3 | b4 | L2 | d1 | sg |
|-----------------------|-------------------|----|----|----|----|----|----|----|----|
| WT-3000   3100   3500 | 1:1               | 40 | 48 | 42 | 28 | 20 | 26 | 12 | M4 |
| WT-3600   3700        | 1:1               | 40 | 48 | 42 | 28 | 30 | 26 | 12 | M4 |

<sup>105)</sup> Gear ratio

Angular drives for heavy duty and hygienic design



drylin® angular drives provide for a maximum of positioning flexibility. The form fitting connection can give a maximum torque of up to 6Nm.

- Flexible adjusting to your installation with continuously variable adjustment (can be oscillated 360°)
- Max. drive torque 6Nm through coupling
- Fixed using feather key groove
- Input shaft Ø 14mm h7 with size
- Compatible with drylin® SHT/SHTC/SLW (sizes 16, 20 and 30)
- Position indicator, lead screw clamp and hand wheel available ► **Page 618**

Dimensions [mm]

| Part No.                     | i <sup>105)</sup> | AW | b1 | b2 | b3 | b4 | L2 | d1 | sg |
|------------------------------|-------------------|----|----|----|----|----|----|----|----|
| WT-4000   4100   4200   4700 | 1:1               | 60 | 52 | 51 | 40 | 23 | 26 | 14 | M4 |
| WT-4600                      | 1:1               | 60 | 52 | 51 | 40 | 33 | 26 | 14 | M4 |

<sup>105)</sup> Gear ratio



Angular drive with hand wheel (optional)

Following the idea of "Hygienic Design" the angular drive is available as maintenance-free and washable stainless steel/polymer system.

- Max. drive torque 3Nm
- Single parts made of stainless steel
- Easy to clean/rinse with water
- Compatible with drylin® SHTC-20-EWM-HYD ► **Page 531**
- Position indicator, lead screw clamp and hand wheel available ► **Page 618**

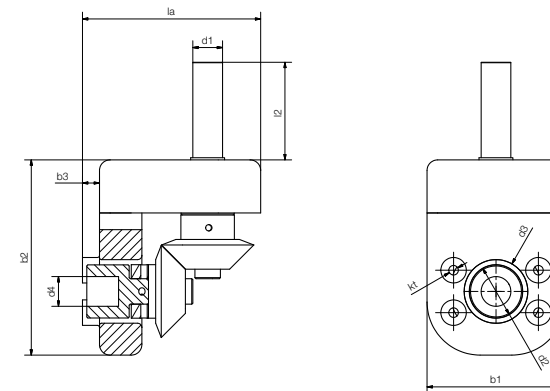

Dimensions [mm]

| Part No. | i <sup>105)</sup> | la | kt  | b1 | b2 | b3 | d4 | l2 | d1 | d2 | d3 | sg |
|----------|-------------------|----|-----|----|----|----|----|----|----|----|----|----|
| WT-1100  | 1:1               | 84 | 4.5 | 65 | 92 | 8  | 12 | 26 | 14 | 25 | 30 | M4 |

<sup>105)</sup> Gear ratio

To keep downtime to a minimum and make adjustments quickly, the indicator is used to create repeatable values. These can be shipped from stock for almost any linear units, in the required counting and viewing direction and in a variety of colours.

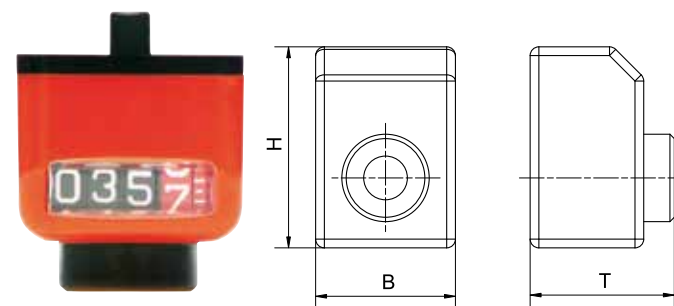

- Plastic analogue indicator for adjustment and direct reading of carriage position
- Counter with 3 (P1), 4 (P3) or 5 (P6) digits (red digit to indicate tenths)
- Can be combined with manual clamps and hand wheels
- Reduction sleeves included
- Suitable adapter plate available ► **Page 687**

**Installation options**



0 degrees    90 degrees    180 degrees    270 degrees

**Display orientation**



**A**  
Standard

**B (optional)**  
for vertical fitting position:  
display turned 180°

**Technical data [mm]**

| Position indicator | Digits | Decimal places | ID hollow shaft<br>∅ | Reduction sleeves<br>∅ |
|--------------------|--------|----------------|----------------------|------------------------|
| SHT-P1             | 3      | 1              | 8                    | 6 + 6.35               |
| SHT-P3             | 4      | 1              | 14                   | 10 + 12.00             |
| SHT-P6             | 5      | 1              | 20                   | 14 + 16.00             |

**Dimensions [mm]**

| Position indicator | H  | B  | T    |
|--------------------|----|----|------|
| SHT-P1             | 33 | 22 | 26.0 |
| SHT-P3             | 46 | 32 | 33.0 |
| SHT-P6             | 66 | 48 | 50.5 |

**Order key**

Order example  
**SHT-P3-A-1.50-1-DX-O-F-ES**

|          |                   |                     |       |                |                    |                |          |          |
|----------|-------------------|---------------------|-------|----------------|--------------------|----------------|----------|----------|
| Standard | Installation size | Display orientation | Pitch | Decimal places | Counting direction | Housing colour | Material | Material |
|----------|-------------------|---------------------|-------|----------------|--------------------|----------------|----------|----------|

**Options:**

- Display orientation**  
A: Display orientation 0°  
B: Display orientation 180° (optional)
- Pitch**  
< 10.00: One decimal place  
> 10.00: No decimal place
- Decimal places**  
1: One decimal place (red digit)  
0: No decimal place (red digit)
- Counting direction**  
DX: clockwise  
SX: anti-clockwise
- Housing colour**  
O: Orange
- Material**  
ES: Hollow stainless steel shaft made from (optional)

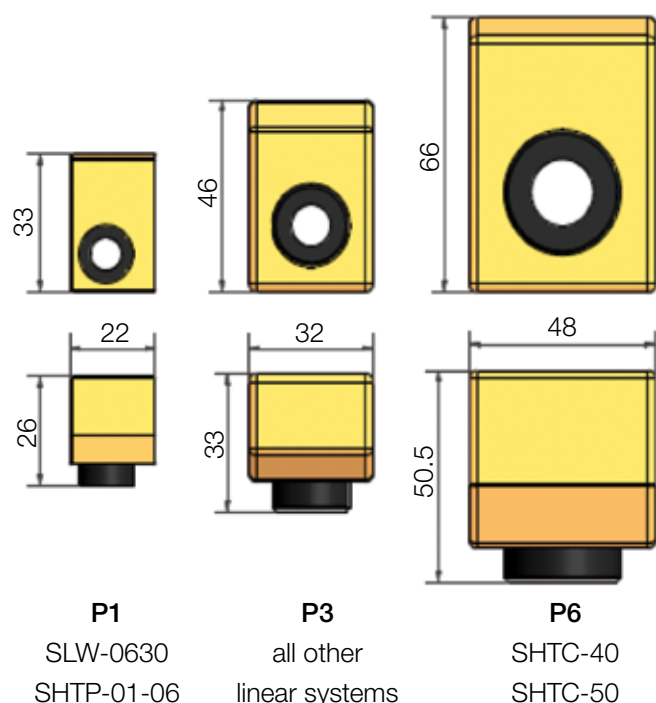

**Order key**

Order example

**SHT-P3-E02-2.00-1-DX-O-S**

|          |                   |                     |       |                |                    |                |          |
|----------|-------------------|---------------------|-------|----------------|--------------------|----------------|----------|
| Standard | Installation size | Display orientation | Pitch | Decimal places | Counting direction | Housing colour | Material |
|----------|-------------------|---------------------|-------|----------------|--------------------|----------------|----------|

**Options:**

**Display orientation**

- E02: Standard: Display orientation 0°
- E04: Display orientation rotated by 180°

The electronic position indicator (battery operated) for drylin® linear modules can be programmed by the factory for the individual thread pitch. Ideal for use with dryspin® high helix lead screws. LCD display with 5 digits and special characters, long battery life and easy battery change without removal of the device.

- Electronic digital display
- 5-digit LCD display
- Features such as incremental adjustment, offset and reset, operated via keys on the position indicator
- Battery life 8 years
- Battery change without any tools
- Increase counting in either direction, clockwise or anti-clockwise
- Display orientation standard or through 180°

Note: reduction sleeves included in delivery

**Technical data**

| Part No.                 | Rotational speed<br>[rpm] | Weight<br>[g] | Temperature<br>[°C] | Protection class |
|--------------------------|---------------------------|---------------|---------------------|------------------|
| SHT-P3-E02-2.00-1-DX-O-S | 600                       | 60            | -10 ... +60         | IP51             |

Lead screw clamp

Linear modules with trapezoidal threads are equipped with a self-locking mechanism. Many applications call for an additional clamping option as an additional safeguard against unintentional movement.



- Shaft clamp adapter for attaching to the position indicator and subsequent clamping of the lead screw.
- Provides a mechanical brake to the lead screw
- Material: plastic housing with aluminium shaft clamp
- Reduction sleeves for further diameters available

Assembly and positioning with adapter plate  
▶ Page 687

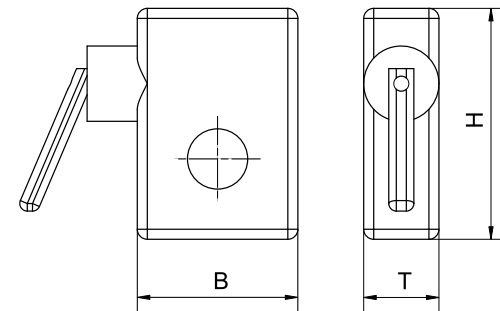

Dimensions [mm]

| Part No.               | SHT-HK-12    | SHT-HK-16    | SHT-HK-20    | SHT-HK-30    |
|------------------------|--------------|--------------|--------------|--------------|
| Lead screw size        | 10           | 14           | 12           | 14           |
| Dimensions (B x H x T) | 32 x 46 x 15 | 32 x 46 x 15 | 32 x 46 x 15 | 32 x 46 x 15 |

Dimensions [mm]

| Part No.               | SHT-HK-06      | SHT-HK-06.35   | SHT-HK-08      |
|------------------------|----------------|----------------|----------------|
| Lead screw size        | 6              | 6.35           | 8              |
| Dimensions (B x H x T) | 23 x 38 x 11.5 | 23 x 38 x 11.5 | 23 x 38 x 11.5 |

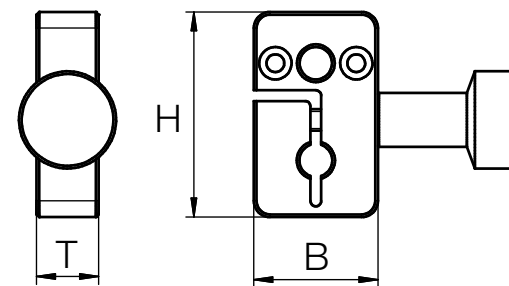

Hand wheels for drylin® linear modules

We have an extensive selection of hand wheels available to ship from stock for the most varied requirements. They range from small, compact sizes up to Ø125 with or without handles and in various configurations.



Standard      With handle (optional)

- Rotary knob: Defined standard for complete units
- Different outer diameters available
- Different handles available

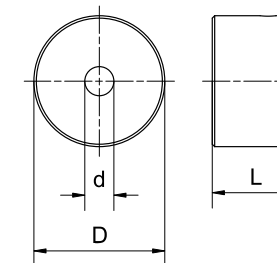

Dimensions [mm]

| d  | D  | L  | OG | FG | UG | SG <sup>104)</sup> |
|----|----|----|----|----|----|--------------------|
| 4  | 22 | 15 | ●  |    |    |                    |
| 5  | 22 | 15 | ●  |    |    |                    |
| 8  | 27 | 17 | ●  | -  | -  | -                  |
| 10 | 27 | 17 | ●  | -  | -  | -                  |
| 12 | 42 | 23 | ●  | -  | -  | -                  |
| 14 | 42 | 23 | ●  | -  | -  | -                  |
| 6  | 50 | 52 | -  | ●  | -  | -                  |
| 8  | 80 | 75 | -  | ●  | ●  | ●                  |

<sup>104)</sup> The automatic panning will return on release

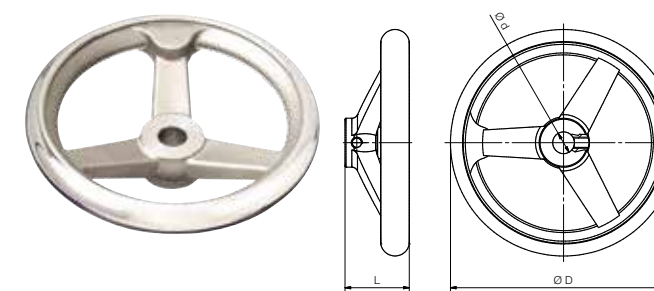

Dimensions [mm]

| Part No.               | d  | D   | L  | OG | Weight [g] |
|------------------------|----|-----|----|----|------------|
| SHT-HR-12-125-36-OG-ES | 12 | 125 | 36 | ●  | 625        |

Order key

Order example

SHT-HR- 8 -27-17-OG



Options:  
Handle (optional)  
OG: Without handle  
FG: Fixed handle  
UG: Folding handle  
SG: Security handle

| d  | D   | L   | OG | FG | UG | SG <sup>104)</sup> |
|----|-----|-----|----|----|----|--------------------|
| 10 | 80  | 75  | -  | ●  | ●  | ●                  |
| 12 | 80  | 75  | -  | ●  | ●  | ●                  |
| 12 | 125 | 109 | -  | ●  | ●  | ●                  |
| 14 | 125 | 109 | -  | ●  | ●  | ●                  |
| 16 | 125 | 109 | -  | ●  | ●  | ●                  |
| 20 | 198 | 141 | -  | ●  | -  | -                  |

Stainless steel hand wheel

- Designed for application in food and pharmaceutical industries
- Corrosion-free stainless steel



Flex shaft - separately located control of linear modules



The ideal complement to drylin® linear modules. The flex shaft enables the positioning of the hand wheel independent of the installation position of the linear unit. Distance up to 500mm and offset by 85°.

- Lengths: 300mm, 500mm und 1,000mm (flexible area)
- Flexible shaft: Burnished steel
- Plastic coated: Rilsan
- Connection piece: Stainless steel AISI 303
- For all journal diameters (10, 12 and 14mm)
- Flexible installation
- Space-saving
- Can be combined with lead screw support block

► Page 484

- Position indicator, lead screw clamp and hand wheel available ► Page 618



Example of the function of an offset operating unit

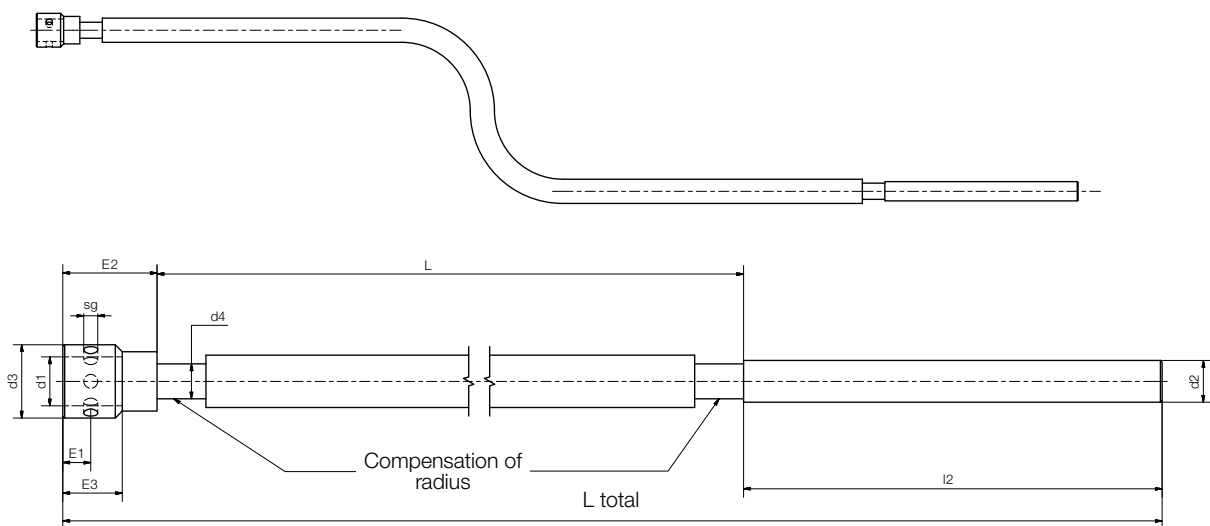

Dimensions [mm]

| Part No.              | d1   | d2   | d3 | d4 | l2  | sg | E1  | E2   | E3   | L     | L total | L max. | T max. | Min. Bend radius |
|-----------------------|------|------|----|----|-----|----|-----|------|------|-------|---------|--------|--------|------------------|
| FS-06-500-Z12X120-AA  | 14h7 | 12h7 | 21 | 6  | 120 | M4 | 8.5 | 36.5 | 14.5 | 500   | 657     | 1,000  | 3      | 70               |
| FS-08-1000-Z12X120-AA | 14h7 | 12h7 | 21 | 8  | 120 | M4 | 8.5 | 36.5 | 14.5 | 1,000 | 1,157   | 1,000  | 4.5    | 90               |

More dimensions upon request

With the drylin® Remote Operation Unit ROU, linear modules can be controlled remotely

With the Remote Operation Unit, hazards such as chemicals or heat can be avoided. Thanks to the flex shaft, they can also be easily manipulated.

- Use e. g. of chemicals, heat, places that are hazardous for people working in them
- Enables manual remote control of linear modules
- Ergonomic operation via flex shaft
- Safe control of linear modules outside the work area
- Available with flex shaft with Ø 6 and 8mm in different lengths
- Thanks to the adapter plate, position indicators as well as lead screw clamps can be fitted in 4 operating directions (0°, 90°, 180°, 270°)
- Reduction sleeves for quick and simple connection to lead screw size Ø8/10/12 available AK-0047 (Ø14->8mm); AK-0048 (Ø14->10mm), AK-0049 (Ø14->12mm)



Typical application areas:

- Format adjustment
- Cabin construction
- Hazard areas

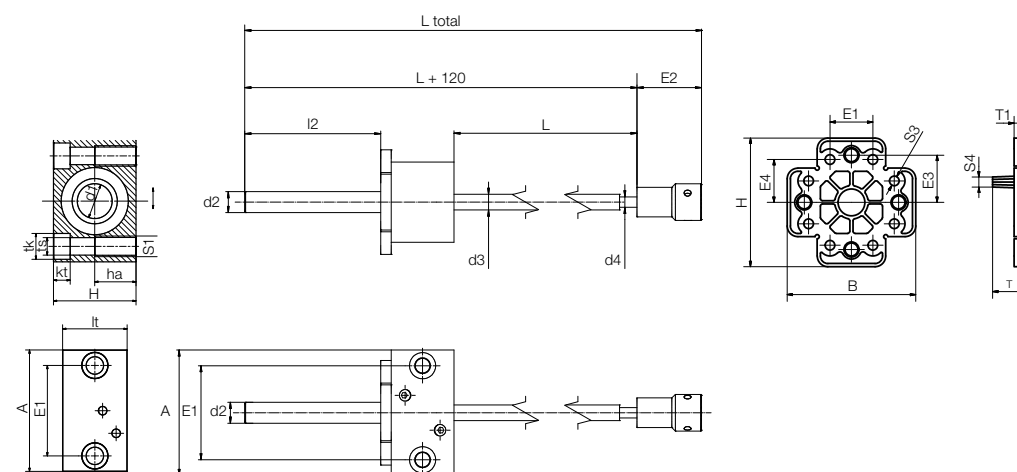

Dimensions [mm]

| Part No.        | L    | L Total | l2 | d2 | d3 | d4 | E1 | E2 | E3 | E4 | S3  | H  |
|-----------------|------|---------|----|----|----|----|----|----|----|----|-----|----|
| SHT-ROU-06-300  | 300  | 457     | 78 | 12 | 9  | 6  | 20 | 37 | 22 | 20 | 4.5 | 60 |
| SHT-ROU-06-500  | 500  | 657     | 78 | 12 | 9  | 6  | 20 | 37 | 22 | 20 | 4.5 | 60 |
| SHT-ROU-08-500  | 500  | 657     | 78 | 12 | 11 | 8  | 20 | 37 | 22 | 20 | 4.5 | 60 |
| SHT-ROU-08-1000 | 1000 | 1157    | 78 | 12 | 11 | 8  | 20 | 37 | 22 | 20 | 4.5 | 60 |

| Part No.        | B  | T1 | A  | E5 | lt | tk | ts | kt  | ha | S1  | d1   |
|-----------------|----|----|----|----|----|----|----|-----|----|-----|------|
| SHT-ROU-06-300  | 60 | 6  | 72 | 54 | 36 | 15 | 9  | 8.6 | 23 | M10 | 14H7 |
| SHT-ROU-06-500  | 60 | 6  | 72 | 54 | 36 | 15 | 9  | 8.6 | 23 | M11 | 14H7 |
| SHT-ROU-08-500  | 60 | 6  | 72 | 54 | 36 | 15 | 9  | 8.6 | 23 | M12 | 14H7 |
| SHT-ROU-08-1000 | 60 | 6  | 72 | 54 | 36 | 15 | 9  | 8.6 | 23 | M13 | 14H7 |

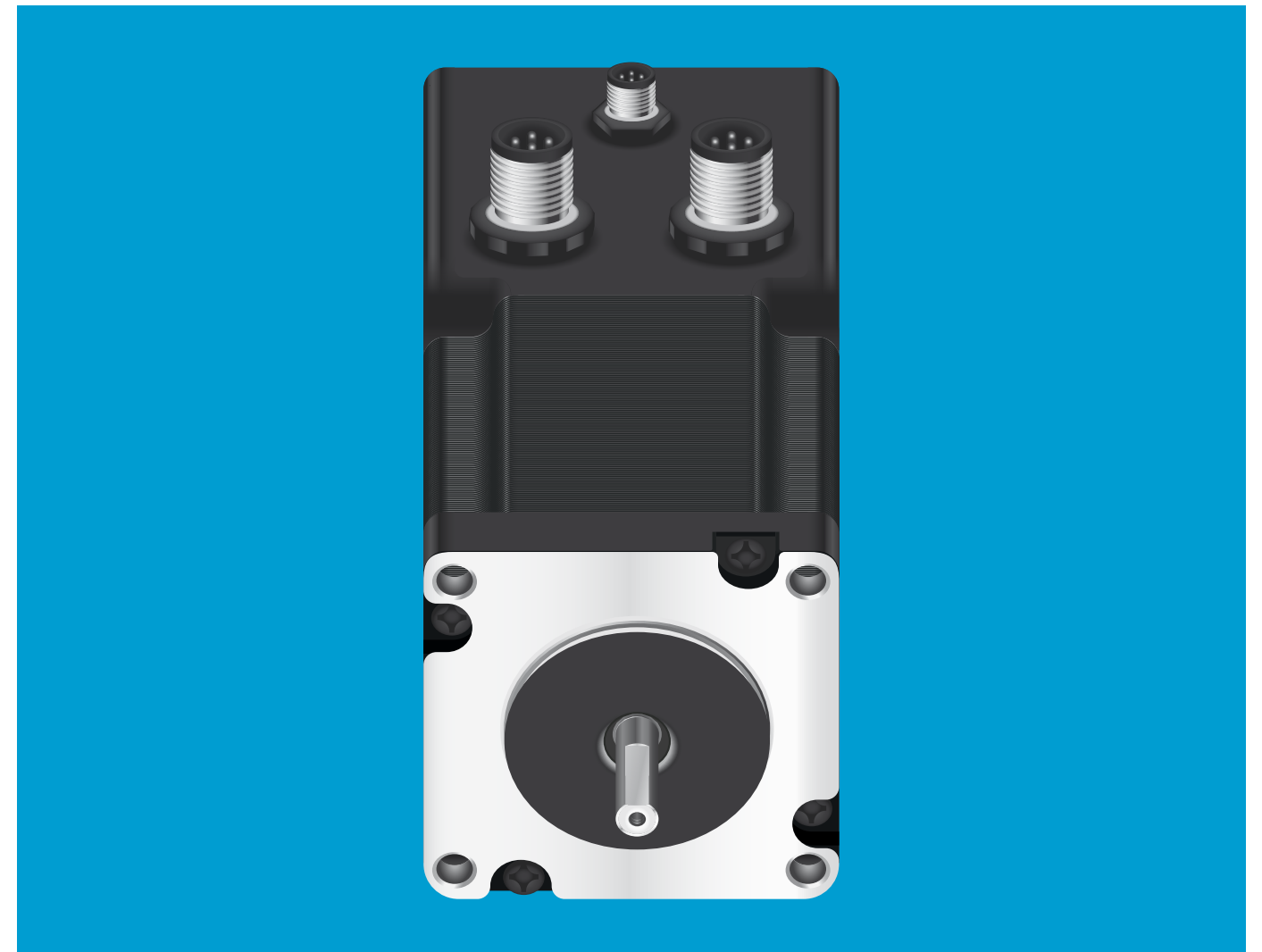
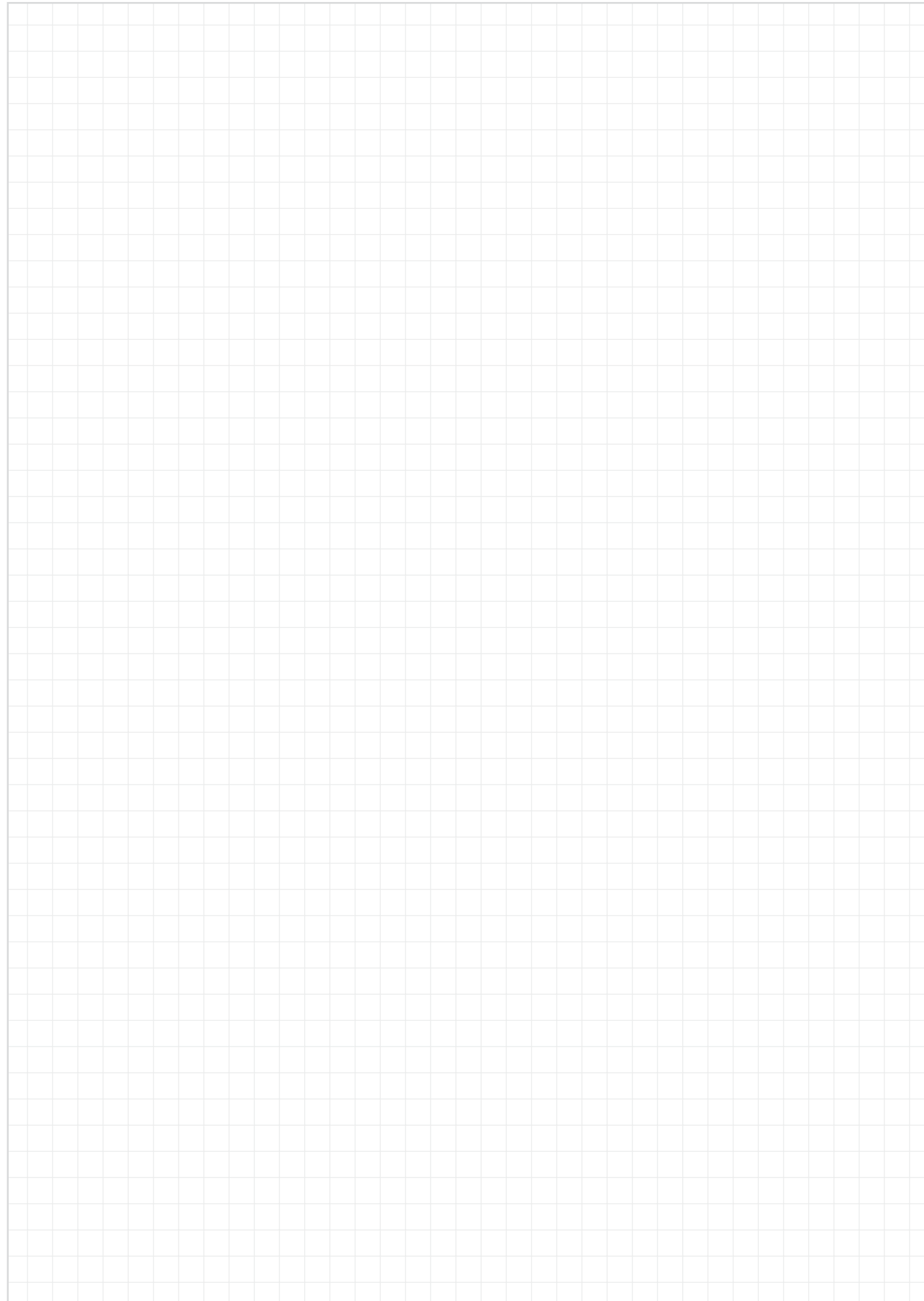

## drylin<sup>®</sup> electric drive technology - motors

2-phase hybrid motor (bipolar)

Protection class up to IP68

Motor connection with metric connector/  
stranded wire or cable

Optional, encoder / brake

Accessories for drive technology





Compatible with the most common motor controls

Positioning also possible without encoder

Available in several installation sizes

High torque

Available for higher plant reliability: encoder and brake

High protection class IP68

Extensive accessories



## Efficient, precise and compact - drylin® E stepper motors

drylin® with the lead screw motor range is the optimum solution for systems that need a stepper motor and integrated lead screw. The stand-alone versions have a compact design and are available with NEMA stepper motors with or without an encoder. The lead screw is centred and, in combination with the dryspin® high helix thread technology, the system has a long service life.

- 5 stepper motor sizes
- Lubrication-free drylin® lead screw technology
- Available ready to connect

### Typical application areas

- Medical technology
- Tool building
- Laboratory technology

-  **Available from stock**  
Detailed information about delivery time online.
-  **Price breaks online**  
No minimum order value. No minimum order quantity
-  **Product finder**  
▶ [www.igus.eu/drylinE-finder](http://www.igus.eu/drylinE-finder)

Stand-alone solution for customer requirements - with or without encoder



- drylin® E - shaft stepper motors**
- Compatible with the most common motor controls
  - Positioning also possible without encoder
  - Available with encoder, brake, encoder and brake as standard
- ▶ Page 633



- drylin® E - lead screw stepper motors**
- Compatible with the most common motor controls
  - Positioning also possible without encoder
  - Available with encoder in short design as standard
- ▶ Page 644



- drylin® - DC motors**
- Planetary gearbox
  - Spur gear
  - Protect variants
- ▶ Page 651



- drylin® - motor drives**
- For igus® stepper motors with flange sizes NEMA 23, 24, 34
  - Available gear reductions: 3, 5, 10, 15, 20, 40
  - Max. output torque for heavy loads
- ▶ Page 666



- drylin® E - specialist stepper motors**
- For vacuum applications
  - For splash water and underwater applications
  - 1m cable
- ▶ Page 640



- drylin® - EC/BLCD motors**
- Compatible with the most common motor controls
  - Positioning also possible without encoder
  - Available with hall, encoder, encoder and brake
- ▶ Page 647



- drylin® - motor control systems**
- For DC, EC and stepper motors
  - Simple and intuitive user interface
  - Quick initial operation
- ▶ Page 662



- drylin® - couplings**
- More than 400 versions from stock
  - Vibration dampening and pluggable
- ▶ Page 669



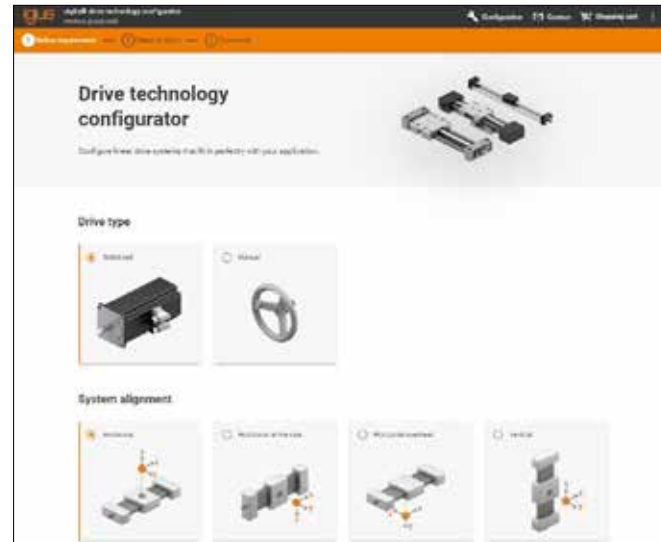

### Configurator for drive technology

Individually configured single axes with electrical drive can be generated with just a few clicks. After the parameters are set, connection cables, proximity switch kits, and control systems can be added.

► [www.igus.eu/DDX](http://www.igus.eu/DDX)

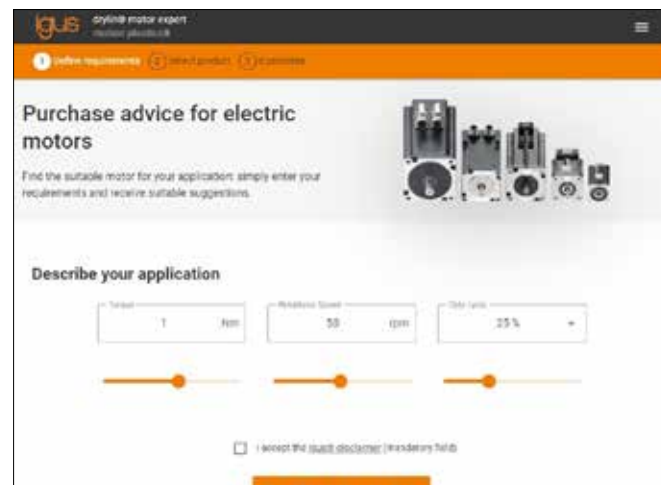

### Configurator for electric motors

After torque and speed is entered, the tool calculates the motor set that is right for you. Reduction gearboxes are included in the tool. You can also choose between encoder and brake.

► [www.igus.eu/DMX](http://www.igus.eu/DMX)

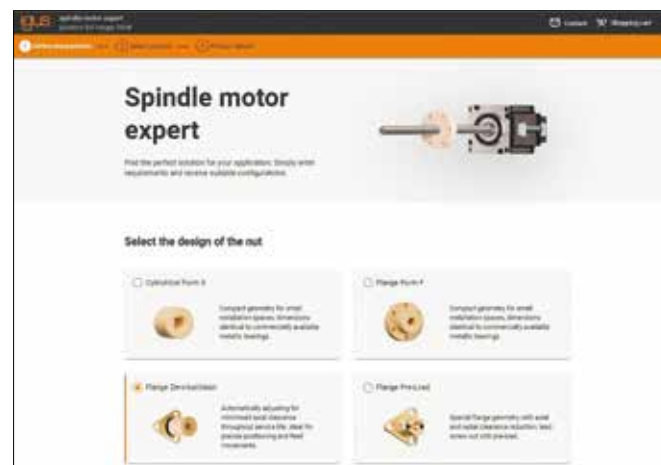

### Configurator for lead screw motors

Our lead screw drive experts help you to find the right linear actuator quickly and determine predicted service life. You can choose among four nut categories and different lead screws.

► [www.igus.eu/DSE](http://www.igus.eu/DSE)



### Winding machine

The requirement for this fabric unwinding system is that it be lubrication-free with adjustable speeds. igus® has the solution with two linear axes running in parallel and connected to a main shaft.

### Cylindrical grinding machine

The customer needs two linear axes for his cylindrical grinding machine, which can move in the hundredth range and when wet. A maximum overall length is also stipulated. The SAW with side installation in conjunction with an IP65 stepper motor is the solution for achieving the desired protection class and maximum overall length.

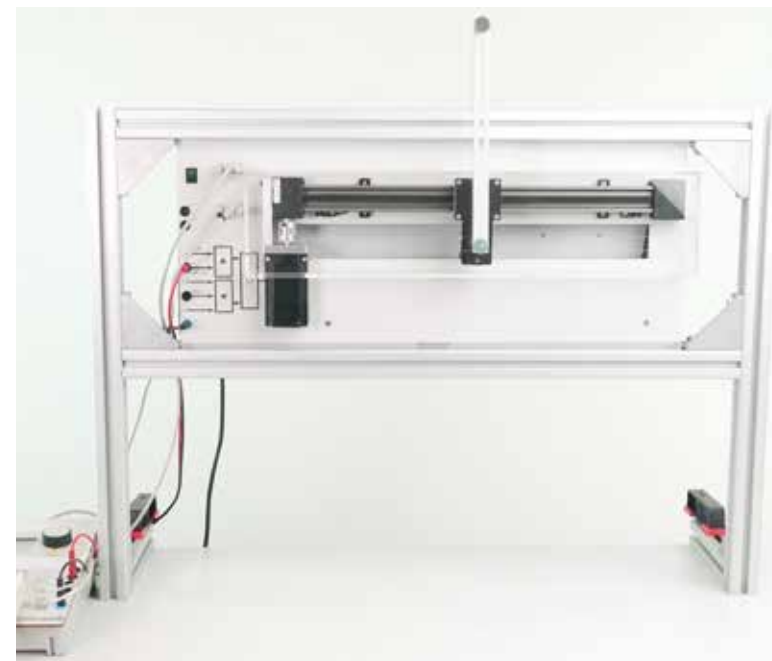

### Pendulum machine

The customer wants to be able to program the parameters for the school laboratory himself. A higher-level control system regulates the D1 drive analogue inputs with an angular encoder attached to the central pendulum pivot point and can thus stipulate the position specifications for erecting the pendulum with the motor.



## Various NEMA stepper motor options



### Motor with stranded wire

Motors with stranded wires are the least expensive and the most common stepper motors. The connecting wires (length 30cm) for this type exit from the housing and will be configured with a JST connector. They are usually installed in machines and equipment that have an additional housing or are used in clean environments.



### Motor with connector

The connector interface provides a high IP65 protection level (IP: International Protection). The higher the IP rating, the better the motor is protected from the ingress of dirt and water.



### Motor with connector and encoder

The encoder (for increased machine reliability) sends signals from the motor to the motor control. The encoder verifies that the required linear motion has occurred precisely as required.



### Motor with connector, encoder and brake

The brake can hold the payload in position when the motor is not under power. This is used as a safety feature during power failures - recommended for vertically mounted systems.

**i** All motors are delivered with a machined flat motor shaft (D-cut) for increased torque resistance.

## Installation sizes of NEMA stepper motors

### NEMA11: tiny but with plenty of power

This motor has very compact dimensions. Even so, heavy loads can be moved with a suitable lead screw pitch. This motor is typically used on small test and analysis equipment and miniature adjustments.

### NEMA17: small, but lots of power

This little motor has impressive torque and high RPMs. Reliable operation at fast travel with low loads.

### NEMA23: the best known stepper motor size

Versatile choice due to the high torque and rotational speed. This motor is the best choice for most applications with medium loads.

### NEMA24: power motor in medium installation size

A development extension of the typical NEMA23 with nearly twice the torque. The assembly dimensions are identical to the NEMA23, allowing many applications.

### NEMA34: the power pack in large installation size

Applications with higher loads are implemented using the largest installation size. Heavy-duty format adjustments or parallel dual axis setups are among its primary duties.

## NEMA dimensions

NEMA stands for "National Electrical Manufacturers Association", an American standardisation organisation comparable to the German DIN Institute or the ISO (International Standard Organization).

Since NEMA is an American association, its dimensions are imperial. The motors are divided into different sizes according to their edge dimensions (flange dimensions). Rounding errors occur during conversion from inches to millimetres.

### Shaft stepper motors

Shaft stepper motors from igus® are maintenance-free and durable. They are available in various sizes and extendable with two connectors, brakes and encoders. The shaft stepper motors are available in installation sizes: NEMA11, 17, 23, 23, 24 and 34 - with flange dimensions 28mm, 42mm, 56mm, 60mm and 86mm. The motors work at temperatures between -10 and +50°C. Thanks to a standardised electrical connection, shaft stepper motors are not only compatible with igus® motor control systems, but also to most commonly available control systems of other manufacturers.

### Lead screw stepper motors

Lead screw stepper motors from igus® are maintenance-free and durable. They are available in various sizes and extendable with encoders. The lead screw stepper motors are available in installation sizes: NEMA11, 17 and 23 - with flange dimensions 28mm, 42mm and 56mm. The motors work at temperatures between -10 and +50°C. Thanks to a standardised electrical connection, lead screw stepper motors are not only compatible with igus® motor control systems, but also to most commonly available control systems of other manufacturers.

### EC/BLDC motors

igus® brushless DC motors are always delivered with three Hall sensors. Encoder and brake are also configured. Carbon brushes are eliminated, allowing up to 30,000 operating hours despite speeds of up to 3,000rpm.

### DC spur gear

DC motors have the drive shaft below the centre of the motor because of the spur gear. The motors can be operated with batteries and the direction of rotation changed by simply reversing polarity.

### DC planetary gearbox

DC motors have the drive shaft in the centre of the motor because of the planetary gearbox. The motors can be operated with batteries and the direction of rotation changed by simply reversing polarity.

### DC protect

DC protect motors can have spur gears or planetary gearboxes as desired. The motors can be operated with batteries and the direction of rotation changed by simply reversing polarity. The protective housing achieves an IP41 protection class.

### DC motors with spline

DC motors with spline are driven after the worm gear with two different plug-in shafts. The motors can be operated with batteries and the direction of rotation changed by simply reversing polarity. The protective housing achieves an IP41 protection class. The motors also have a Hall sensor that ensures greater machine reliability.

### Linear actuator

Linear actuators are an interaction of lead screw stepper motor with lead screws and motors. In the igus® product range, they are available in installation sizes: NEMA11, 17 and 23 - with flange dimensions 28mm, 42mm and 56mm. Thanks to a standardised electrical connection, shaft stepper motors are not only compatible with igus® motor control systems, but also to most commonly available control systems of other manufacturers.



- Compatible with the most common motor controls
- Positioning also possible without encoder
- Available in several installation sizes
- Holding torque up to 3.6Nm
- Protection class: IP40

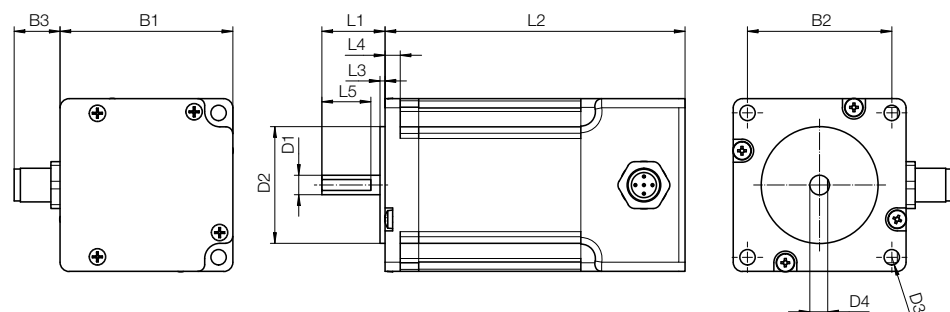

## Technical data

| Part No.                      | Distance over hubs | NEMA   | Connection          | Nominal current | Holding torque | Weight |
|-------------------------------|--------------------|--------|---------------------|-----------------|----------------|--------|
|                               | [mm]               |        |                     |                 |                |        |
| MOT-AN-S-060-001-028-L-A-AAAO | 28                 | NEMA11 | JST stranded wire   | 0.7             | 0.06           | 0.11   |
| MOT-AN-S-060-001-028-L-C-AAAO | 28                 | NEMA11 | JST stranded wire   | 0.7             | 0.06           | 0.11   |
| MOT-AN-S-060-002-042-L-A-AAAO | 42                 | NEMA17 | JST stranded wire   | 1.4             | 0.20           | 0.17   |
| MOT-AN-S-060-002-042-L-C-AAAO | 42                 | NEMA17 | JST stranded wire   | 1.4             | 0.20           | 0.17   |
| MOT-AN-S-060-010-056-L-A-AAAO | 56                 | NEMA23 | JST stranded wire   | 2.8             | 1.00           | 0.61   |
| MOT-AN-S-060-010-056-L-C-AAAO | 56                 | NEMA23 | JST stranded wire   | 2.8             | 1.00           | 0.61   |
| MOT-AN-S-060-016-060-L-A-AAAO | 60                 | NEMA24 | JST stranded wire   | 4.3             | 1.70           | 0.75   |
| MOT-AN-S-060-016-060-L-C-AAAO | 60                 | NEMA24 | JST stranded wire   | 4.3             | 1.70           | 0.75   |
| MOT-AN-S-060-036-086-L-A-AAAO | 86                 | NEMA34 | Molex stranded wire | 6.4             | 3.60           | 1.80   |
| MOT-AN-S-060-036-086-L-C-AAAO | 86                 | NEMA34 | Molex stranded wire | 6.4             | 3.60           | 1.80   |

## Dimensions [mm]

| Part No.                      | L1   | L2   | L6   | D1     | D2     | B1   | B2    |
|-------------------------------|------|------|------|--------|--------|------|-------|
|                               | ±1.0 | ±1.0 | ±1.0 | -0.013 | ±0.025 | ±0.2 | ±0.2  |
| MOT-AN-S-060-001-028-L-A-AAAO | 20.0 | 31.5 | -    | 5.00   | 22.00  | 28.0 | 23.00 |
| MOT-AN-S-060-001-028-L-C-AAAO | 20.0 | 31.5 | 10.0 | 5.00   | 22.00  | 28.0 | 23.00 |
| MOT-AN-S-060-002-042-L-A-AAAO | 24.0 | 30.5 | -    | 5.00   | 22.00  | 42.3 | 31.00 |
| MOT-AN-S-060-002-042-L-C-AAAO | 24.0 | 30.5 | 15.7 | 5.00   | 22.00  | 42.3 | 31.00 |
| MOT-AN-S-060-010-056-L-A-AAAO | 20.6 | 50.0 | -    | 6.35   | 38.10  | 56.4 | 47.14 |
| MOT-AN-S-060-010-056-L-C-AAAO | 20.6 | 50.0 | 15.7 | 6.35   | 38.10  | 56.4 | 47.14 |
| MOT-AN-S-060-016-060-L-A-AAAO | 20.6 | 56.0 | -    | 8.00   | 38.10  | 60.0 | 47.14 |
| MOT-AN-S-060-016-060-L-C-AAAO | 20.6 | 56.0 | 15.7 | 8.00   | 38.10  | 60.0 | 47.14 |
| MOT-AN-S-060-036-086-L-A-AAAO | 37.0 | 66.0 | -    | 14.00  | 73.02  | 85.8 | 69.50 |
| MOT-AN-S-060-036-086-L-C-AAAO | 37.0 | 66.0 | 15.7 | 14.00  | 73.02  | 85.8 | 69.50 |

 Further technical data, downloads and ordering options at ► [www.igus.eu/motors](http://www.igus.eu/motors)



- Compatible with the most common motor controls
- Positioning also possible without encoder
- Available in several installation sizes
- Holding torque up to 5.9Nm
- Protection class: IP40 or IP52

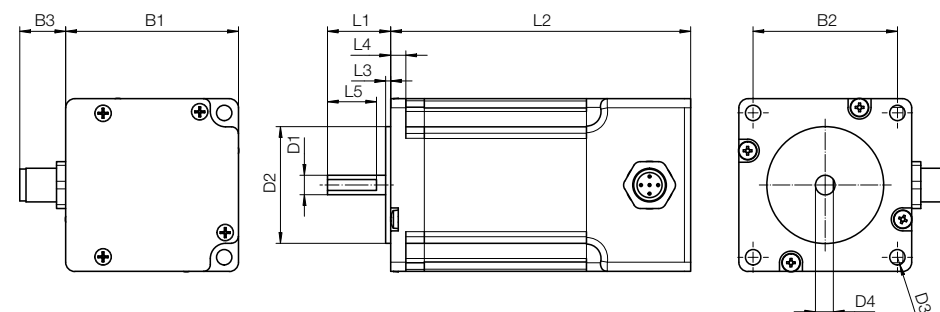

## Technical data

| Part No.                      | Distance over hubs | NEMA   | Connection          | Nominal current | Holding torque | Weight |
|-------------------------------|--------------------|--------|---------------------|-----------------|----------------|--------|
|                               | [mm]               |        |                     |                 |                |        |
| MOT-AN-S-060-001-028-L-A-AAAA | 28                 | NEMA11 | JST stranded wire   | 1.0             | 0.12           | 0.20   |
| MOT-AN-S-060-001-028-M-A-AAAA | 28                 | NEMA11 | Metric              | 1.0             | 0.12           | 0.22   |
| MOT-AN-S-060-005-042-L-A-AAAA | 42                 | NEMA17 | JST stranded wire   | 1.8             | 0.50           | 0.38   |
| MOT-AN-S-060-005-042-M-A-AAAA | 42                 | NEMA17 | Metric              | 1.8             | 0.50           | 0.43   |
| MOT-AN-S-060-020-056-L-A-AAAA | 56                 | NEMA23 | JST stranded wire   | 4.2             | 2.00           | 1.04   |
| MOT-AN-S-060-020-056-M-A-AAAA | 56                 | NEMA23 | Metric              | 4.2             | 2.00           | 1.12   |
| MOT-AN-S-060-035-060-L-A-AAAA | 60                 | NEMA24 | JST stranded wire   | 4.2             | 3.50           | 1.45   |
| MOT-AN-S-060-035-060-M-A-AAAA | 60                 | NEMA24 | Metric              | 4.2             | 3.50           | 1.56   |
| MOT-AN-S-060-059-086-L-A-AAAA | 86                 | NEMA34 | Molex stranded wire | 6.4             | 5.90           | 2.90   |
| MOT-AN-S-060-059-086-M-A-AAAA | 86                 | NEMA34 | Metric              | 6.4             | 5.90           | 3.20   |

## Dimensions [mm]

| Part No.                      | L1   | L2   | D1     | D2     | B1   | B2    | B3   |
|-------------------------------|------|------|--------|--------|------|-------|------|
|                               | ±1.0 | ±1.0 | -0.013 | ±0.025 | ±0.2 | ±0.2  |      |
| MOT-AN-S-060-001-028-L-A-AAAA | 20.0 | 50   | 5.00   | 22.00  | 28.0 | 23.00 | -    |
| MOT-AN-S-060-001-028-M-A-AAAA | 20.0 | 70   | 5.00   | 22.00  | 28.0 | 23.00 | 13.0 |
| MOT-AN-S-060-005-042-L-A-AAAA | 24.0 | 49   | 5.00   | 22.00  | 42.3 | 31.00 | -    |
| MOT-AN-S-060-005-042-M-A-AAAA | 24.0 | 70   | 5.00   | 22.00  | 42.3 | 31.00 | 13.0 |
| MOT-AN-S-060-020-056-L-A-AAAA | 20.6 | 76   | 6.35   | 38.10  | 56.4 | 47.14 | -    |
| MOT-AN-S-060-020-056-M-A-AAAA | 20.6 | 98   | 6.35   | 38.10  | 56.4 | 47.14 | 13.0 |
| MOT-AN-S-060-035-060-L-A-AAAA | 20.6 | 88   | 8.00   | 38.10  | 60.0 | 47.14 | 9.0  |
| MOT-AN-S-060-035-060-M-A-AAAA | 20.6 | 112  | 8.00   | 38.10  | 60.0 | 47.14 | 13.0 |
| MOT-AN-S-060-059-086-L-A-AAAA | 37.0 | 98   | 14.00  | 73.02  | 85.8 | 69.50 | -    |
| MOT-AN-S-060-059-086-M-A-AAAA | 37.0 | 118  | 14.00  | 73.02  | 85.8 | 69.50 | 37.0 |

 Further technical data, downloads and ordering options at ► [www.igus.eu/motors](http://www.igus.eu/motors)



- Compatible with the most common motor controls
- Available in several installation sizes
- Holding torque up to 5.9Nm
- Protection class: IP40 or IP52
- Encoder with 500PPR

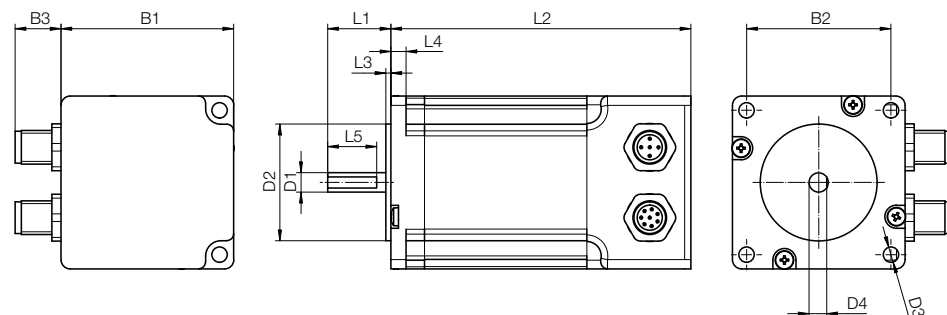

## Technical data

| Part No.                      | Distance over hubs<br>[mm] | NEMA   | Connection          | Nominal current<br>[A] | Holding torque<br>[Nm] | Weight<br>[kg] |
|-------------------------------|----------------------------|--------|---------------------|------------------------|------------------------|----------------|
| MOT-AN-S-060-001-028-L-C-AAAC | 28                         | NEMA11 | JST stranded wire   | 1.0                    | 0.12                   | 0.27           |
| MOT-AN-S-060-005-042-L-C-AAAC | 42                         | NEMA17 | JST stranded wire   | 1.8                    | 0.50                   | 0.40           |
| MOT-AN-S-060-005-042-M-C-AAAC | 42                         | NEMA17 | Metric              | 1.8                    | 0.50                   | 0.45           |
| MOT-AN-S-060-020-056-L-C-AAAC | 56                         | NEMA23 | JST stranded wire   | 4.2                    | 2.00                   | 1.05           |
| MOT-AN-S-060-020-056-M-C-AAAC | 56                         | NEMA23 | Metric              | 4.2                    | 2.00                   | 1.14           |
| MOT-AN-S-060-035-060-L-C-AAAC | 60                         | NEMA24 | JST stranded wire   | 4.2                    | 3.50                   | 1.35           |
| MOT-AN-S-060-035-060-M-C-AAAC | 60                         | NEMA24 | Metric              | 4.2                    | 3.50                   | 1.58           |
| MOT-AN-S-060-059-086-L-C-AAAC | 86                         | NEMA34 | Molex stranded wire | 6.4                    | 5.90                   | 2.95           |
| MOT-AN-S-060-059-086-M-C-AAAC | 86                         | NEMA34 | Metric              | 6.4                    | 5.90                   | 3.30           |

## Dimensions [mm]

| Part No.                      | L1   | L2   | L6 | D1     | D2     | B1   | B2    | B3   |
|-------------------------------|------|------|----|--------|--------|------|-------|------|
|                               | ±1.0 | ±1.0 |    | -0.013 | ±0.025 | ±0.2 | ±0.2  | ±0.2 |
| MOT-AN-S-060-001-028-L-C-AAAC | 20.0 | 50   | 10 | 5.00   | 22.00  | 28.0 | 23.00 | -    |
| MOT-AN-S-060-005-042-L-C-AAAC | 24.0 | 49   | 14 | 5.00   | 22.00  | 42.3 | 31.00 | -    |
| MOT-AN-S-060-005-042-M-C-AAAC | 24.0 | 70   | -  | 5.00   | 22.00  | 42.3 | 31.00 | 13.0 |
| MOT-AN-S-060-020-056-L-C-AAAC | 20.6 | 76   | 15 | 6.35   | 38.10  | 56.4 | 47.14 | -    |
| MOT-AN-S-060-020-056-M-C-AAAC | 20.6 | 98   | -  | 6.35   | 38.10  | 56.4 | 47.14 | 13.0 |
| MOT-AN-S-060-035-060-L-C-AAAC | 20.6 | 88   | 17 | 8.00   | 38.10  | 60.0 | 47.14 | 9.0  |
| MOT-AN-S-060-035-060-M-C-AAAC | 20.6 | 112  | -  | 8.00   | 38.10  | 60.0 | 47.14 | 13.0 |
| MOT-AN-S-060-059-086-L-C-AAAC | 37.0 | 98   | 15 | 14.00  | 73.02  | 85.8 | 69.50 | -    |
| MOT-AN-S-060-059-086-M-C-AAAC | 37.0 | 118  | -  | 14.00  | 73.02  | 85.8 | 69.50 | 37.0 |

 Further technical data, downloads and ordering options at ► [www.igus.eu/motors](http://www.igus.eu/motors)



- Compatible with the most common motor controls
- Available in several installation sizes
- Holding torque up to 5.9Nm
- Protection class: IP40
- Brake up to 2Nm holding torque

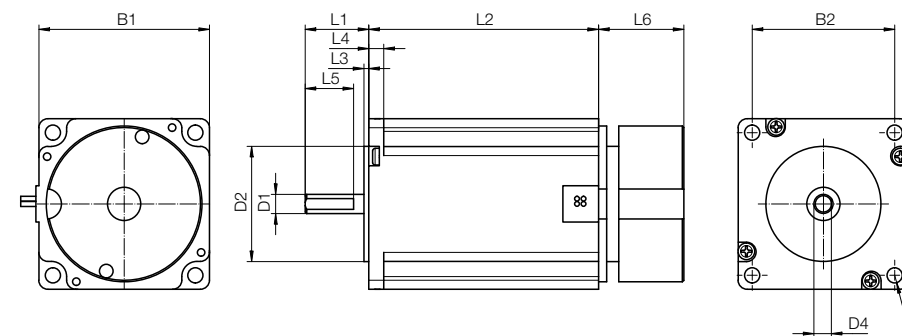

## Technical data

| Part No.                      | Distance over hubs<br>[mm] | NEMA   | Connection          | Nominal current<br>[A] | Holding torque<br>[Nm] | Brake holding torque<br>[Nm] | Weight<br>[kg] |
|-------------------------------|----------------------------|--------|---------------------|------------------------|------------------------|------------------------------|----------------|
| MOT-AN-S-060-005-042-L-B-AAAA | 42                         | NEMA17 | JST stranded wire   | 1.8                    | 0.5                    | 0.5                          | 0.5            |
| MOT-AN-S-060-020-056-L-B-AAAA | 56                         | NEMA23 | JST stranded wire   | 4.2                    | 2.0                    | 1.0                          | 1.3            |
| MOT-AN-S-060-035-060-L-B-AAAA | 60                         | NEMA24 | JST stranded wire   | 4.2                    | 3.5                    | 1.0                          | 1.7            |
| MOT-AN-S-060-059-086-L-B-AAAA | 86                         | NEMA34 | Molex stranded wire | 6.4                    | 5.9                    | 2.0                          | 3.3            |

## Dimensions [mm]

| Part No.                      | L1   | L2   | L6 | D1     | D2     | B1   | B2    |
|-------------------------------|------|------|----|--------|--------|------|-------|
|                               | ±1.0 | ±1.0 |    | -0.013 | ±0.025 | ±0.2 | ±0.2  |
| MOT-AN-S-060-005-042-L-B-AAAA | 24.0 | 49   | 29 | 5.00   | 22.0   | 42.3 | 31.0  |
| MOT-AN-S-060-020-056-L-B-AAAA | 20.6 | 76   | 29 | 6.35   | 38.1   | 56.4 | 47.14 |
| MOT-AN-S-060-035-060-L-B-AAAA | 20.6 | 88   | 30 | 8.00   | 38.1   | 60.0 | 47.14 |
| MOT-AN-S-060-059-086-L-B-AAAA | 37.0 | 98   | 32 | 14.00  | 73.02  | 85.8 | 69.5  |

 Further technical data, downloads and ordering options at ► [www.igus.eu/motors](http://www.igus.eu/motors)





- Compatible with the most common motor controls
- Available in several installation sizes
- Holding torque up to 5.9Nm
- Protection class: IP52
- Encoder with 500PPR
- Brake up to 2Nm holding torque

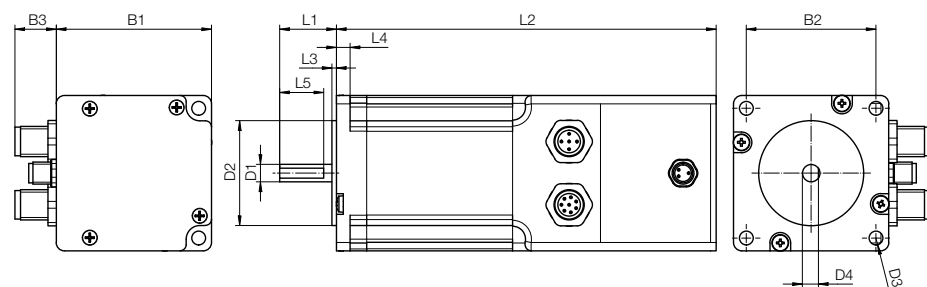

## Technical data

| Part No.                      | Flange dimension<br>[mm] | NEMA   | Connection | Nominal current<br>[A] | Holding torque<br>[Nm] | Brake holding torque<br>[Nm] | Weight<br>[kg] |
|-------------------------------|--------------------------|--------|------------|------------------------|------------------------|------------------------------|----------------|
| MOT-AN-S-060-005-042-M-D-AAAD | 42                       | NEMA17 | Metric     | 1.8                    | 0.5                    | 0.4                          | 0.58           |
| MOT-AN-S-060-020-056-M-D-AAAD | 56                       | NEMA23 | Metric     | 4.2                    | 2.0                    | 1.0                          | 1.36           |
| MOT-AN-S-060-035-060-M-D-AAAD | 60                       | NEMA24 | Metric     | 4.2                    | 3.5                    | 1.0                          | 1.82           |
| MOT-AN-S-060-059-086-M-D-AAAD | 86                       | NEMA34 | Metric     | 6.4                    | 5.9                    | 2.0                          | 3.60           |

## Dimensions [mm]

| Part No.                      | L1   | L2   | D1     | D2     | B1   | B2    | B3   |
|-------------------------------|------|------|--------|--------|------|-------|------|
|                               | ±1.0 | ±1.0 | -0.013 | ±0.025 | ±0.2 | ±0.2  |      |
| MOT-AN-S-060-005-042-M-D-AAAD | 24.0 | 115  | 5.00   | 22.00  | 42.3 | 31.00 | 13.0 |
| MOT-AN-S-060-020-056-M-D-AAAD | 20.6 | 138  | 6.35   | 38.10  | 56.4 | 47.14 | 13.0 |
| MOT-AN-S-060-035-060-M-D-AAAD | 20.6 | 150  | 8.00   | 38.10  | 60.0 | 47.14 | 13.0 |
| MOT-AN-S-060-059-086-M-D-AAAD | 37.0 | 188  | 14.00  | 73.02  | 85.8 | 69.50 | 37.0 |

 Further technical data, downloads and ordering options at ► [www.igus.eu/motors](http://www.igus.eu/motors)



- Compatible with the most common motor controls
- Available in several installation sizes
- Holding torque up to 3.5Nm
- Protection class IP65 thanks to the shaft seal
- Encoder with 500PPR

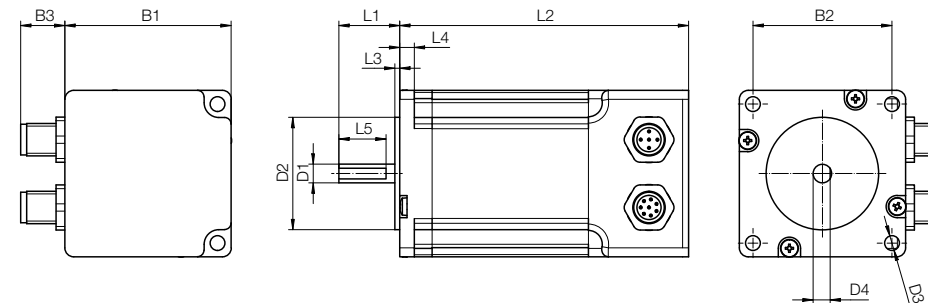

## Technical data

| Part No.                      | Distance over hubs<br>[mm] | NEMA   | Connection | Nominal current<br>[A] | Holding torque<br>[Nm] | Weight<br>[kg] |
|-------------------------------|----------------------------|--------|------------|------------------------|------------------------|----------------|
| MOT-AN-S-060-005-042-M-C-AAAS | 42                         | NEMA17 | Metric     | 1.8                    | 0.5                    | 0.45           |
| MOT-AN-S-060-020-056-M-C-AAAS | 56                         | NEMA23 | Metric     | 4.2                    | 2.0                    | 1.14           |
| MOT-AN-S-060-035-060-M-C-AAAS | 60                         | NEMA24 | Metric     | 4.2                    | 3.5                    | 1.58           |

## Dimensions [mm]

| Part No.                      | L1   | L2   | D1     | D2     | B1   | B2    | B3   |
|-------------------------------|------|------|--------|--------|------|-------|------|
|                               | ±1.0 | ±1.0 | -0.013 | ±0.025 | ±0.2 | ±0.2  |      |
| MOT-AN-S-060-005-042-M-C-AAAS | 24.0 | 73   | 5.00   | 22.0   | 42.3 | 31.00 | 13.0 |
| MOT-AN-S-060-020-056-M-C-AAAS | 20.6 | 99   | 6.35   | 38.1   | 56.4 | 47.14 | 13.0 |
| MOT-AN-S-060-035-060-M-C-AAAS | 20.6 | 112  | 8.00   | 38.1   | 60.0 | 47.14 | 13.0 |

 Further technical data, downloads and ordering options at ► [www.igus.eu/motors](http://www.igus.eu/motors)



Characteristic curves in medium length

Flange size 28 (NEMA11)

MOT-AN-S-060-001-028-...

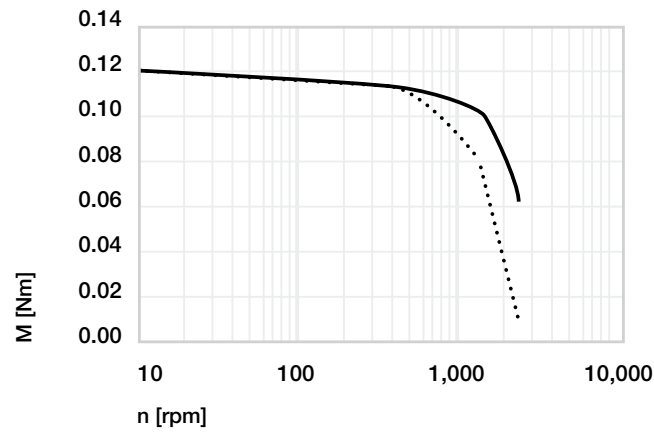

Flange size 42 (NEMA17)

MOT-AN-S-060-005-042-...

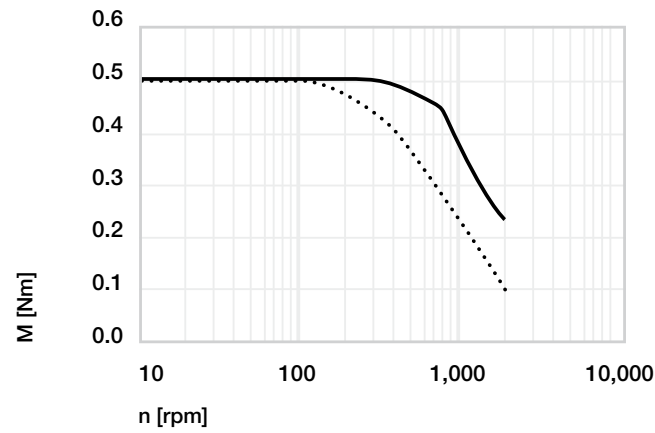

Flange size 56 (NEMA23)

MOT-AN-S-060-020-056-...

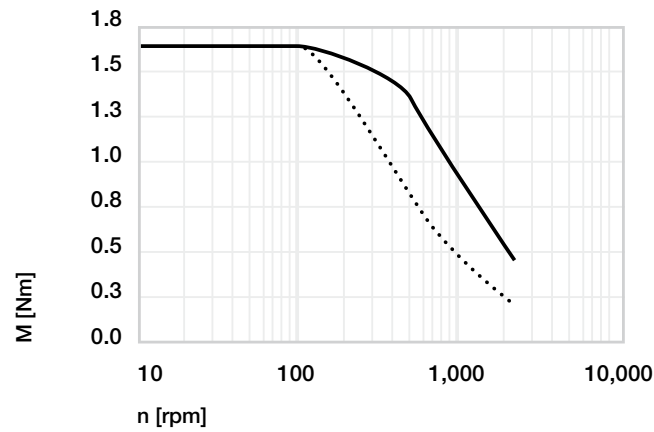

Flange size 60 (NEMA24)

MOT-AN-S-060-035-060-...

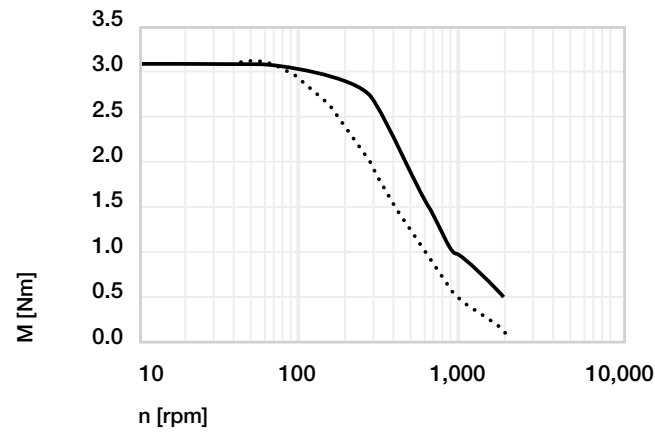

Flange size 86 (NEMA34)

MOT-AN-S-060-059-086-...

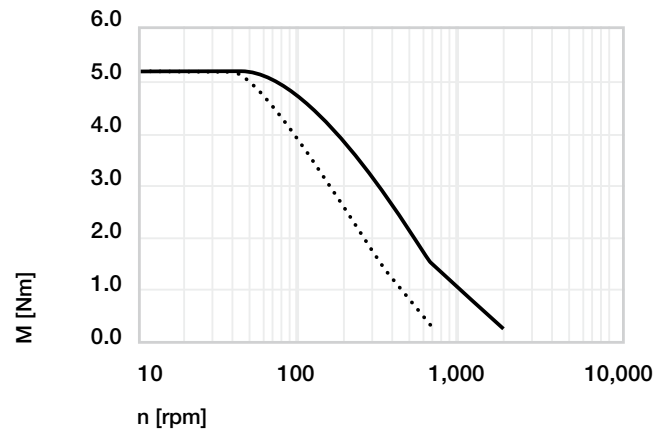

----- 24VDC      ——— 48VDC

The characteristic curves are determined in quarter step mode

Characteristic curves in short length

Flange size 42 (NEMA17)

MOT-AN-S-060-002-042-...-AAAO

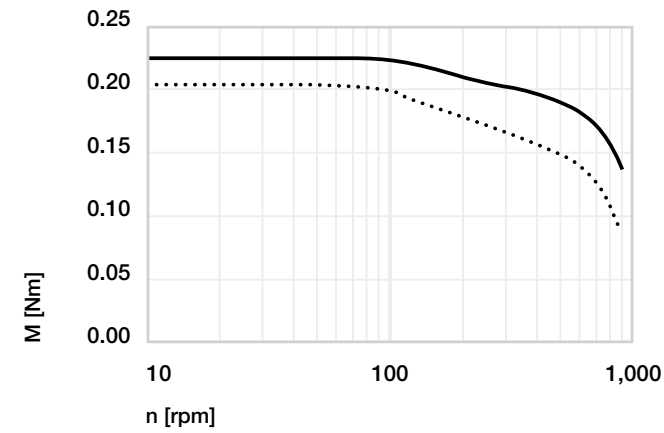

Flange size 56 (NEMA23)

MOT-AN-S-060-010-056-...-AAAO

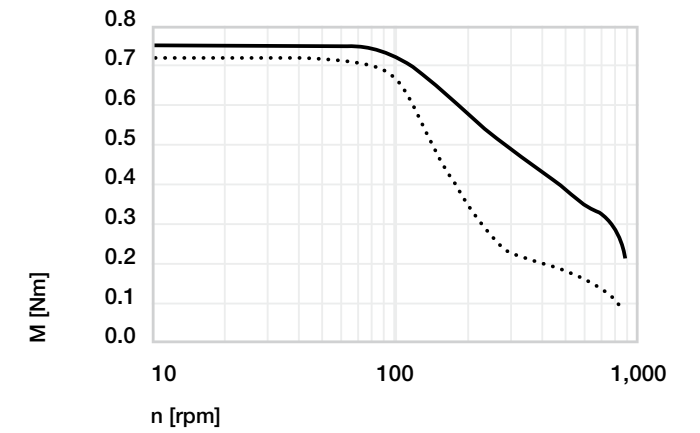

Flange size 60 (NEMA24)

MOT-AN-S-060-016-060-...-AAAO

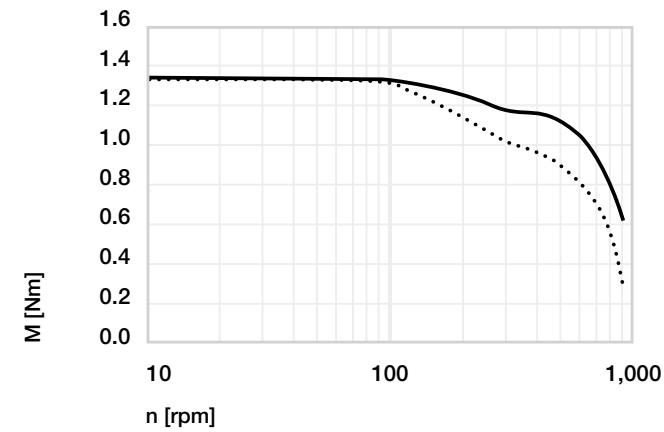

Flange size 86 (NEMA34)

MOT-AN-S-060-036-086-...-AAAO

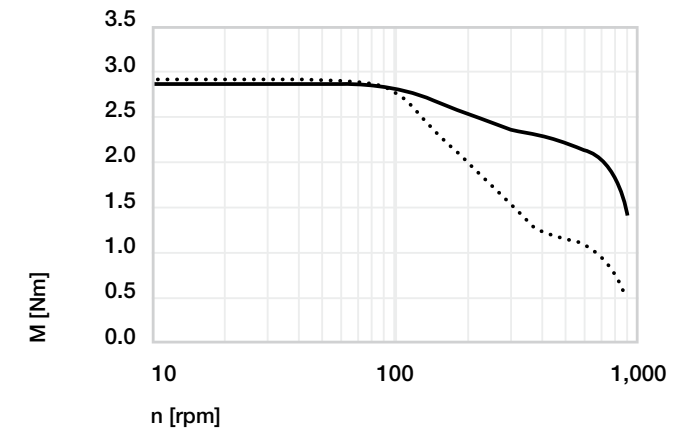

Characteristic curves for specialist stepper motors

Flange size 86 (NEMA34)

MOT-ST-086-C-A-C

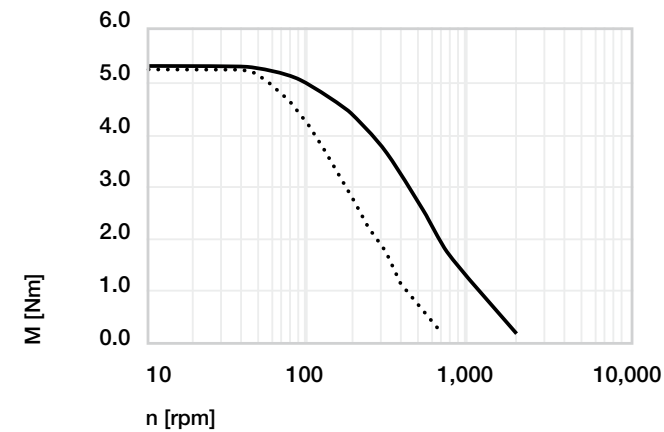

----- 24VDC      ——— 48VDC

The characteristic curves are determined in quarter step mode



- Compatible with the most common motor controls
- Available in several installation sizes
- Holding torque up to 5.9Nm
- Protection class from IP00 up to IP68

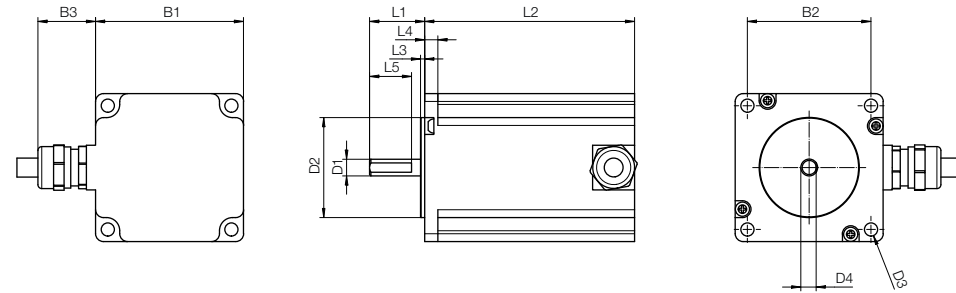

Technical data

| Part No.                                 | Distance over hubs [mm] | NEMA   | Connection    | Nominal current [A] | Holding torque [Nm] | Weight [kg] |
|--|-------------------------|--------|---------------|---------------------|---------------------|-------------|
| MOT-AD-S-060-017-056-M-A-AAAK <b>New</b> | 56                      | NEMA23 | Metric        | 3.0                 | 1.7                 | 1.20        |
| MOT-AD-S-060-017-056-M-C-AAAL <b>New</b> | 56                      | NEMA23 | Metric        | 3.0                 | 1.7                 | 1.25        |
| MOT-AP-S-060-013-056-K-A-AAAI <b>New</b> | 56                      | NEMA23 | Terminal box  | 4.2                 | 1.3                 | 1.47        |
| MOT-AP-S-060-013-056-K-C-AAAM <b>New</b> | 56                      | NEMA23 | Terminal box  | 4.2                 | 1.3                 | 1.51        |
| MOT-AP-S-060-007-056-L-A-AAAJ <b>New</b> | 56                      | NEMA23 | Stranded wire | 2.5                 | 0.7                 | 1.00        |
| MOT-ST-42-C-A-C <b>New</b>               | 42                      | NEMA17 | Molex cable   | 1.8                 | 0.5                 | 0.40        |
| MOT-ST-56-C-A-C <b>New</b>               | 56                      | NEMA23 | Molex cable   | 4.2                 | 2.0                 | 1.04        |
| MOT-ST-60-C-A-C <b>New</b>               | 60                      | NEMA24 | Molex cable   | 4.2                 | 3.5                 | 1.50        |
| MOT-ST-86-C-A-C <b>New</b>               | 86                      | NEMA34 | Molex cable   | 6.4                 | 5.9                 | 3.10        |

Dimensions [mm]

| Part No.                                 | L1   | L2    | L3    | L5   | D1     | D2    | B1    | B2    |
|--|------|-------|-------|------|--------|-------|-------|-------|
|  | ±1.0 | ±1.0  | ±0.25 | ±1.0 | -0.015 | ±0.05 | ±0.2  | ±0.2  |
| MOT-AD-S-060-017-056-M-A-AAAK <b>New</b> | 20.6 | 106   | -     | 16   | 6.35   | 38.10 | 56.40 | 47.14 |
| MOT-AD-S-060-017-056-M-C-AAAL <b>New</b> | 20.6 | 106   | -     | 16   | 6.35   | 38.10 | 56.40 | 47.14 |
| MOT-AP-S-060-013-056-K-A-AAAI <b>New</b> | 17.0 | 134   | -     | -    | 6.35   | 38.10 | 56.80 | 47.10 |
| MOT-AP-S-060-013-056-K-C-AAAM <b>New</b> | 17.0 | 154   | -     | -    | 6.35   | 38.10 | 56.80 | 47.10 |
| MOT-AP-S-060-007-056-L-A-AAAJ <b>New</b> | 22.0 | 74.0  | -     | -    | 6.35   | 38.10 | 59.95 | 47.00 |
| MOT-ST-42-C-A-C <b>New</b>               | 24.0 | 53.0  | 2.0   | -    | -      | 22.00 | 42.3  | 31.00 |
| MOT-ST-56-C-A-C <b>New</b>               | 21.0 | 80.0  | 1.6   | -    | -      | 38.10 | 56.4  | 47.10 |
| MOT-ST-60-C-A-C <b>New</b>               | 21.0 | 94.5  | 1.6   | -    | -      | 38.10 | 60.0  | 47.10 |
| MOT-ST-86-C-A-C <b>New</b>               | 37.0 | 110.0 | 1.6   | -    | -      | 73.00 | 86.0  | 69.60 |

Further technical data, downloads and ordering options at ► [www.igus.eu/motors](http://www.igus.eu/motors)

Flange size 56 (NEMA23)

MOT-AD-S-060-017-056-M-... (IP65 splash water)

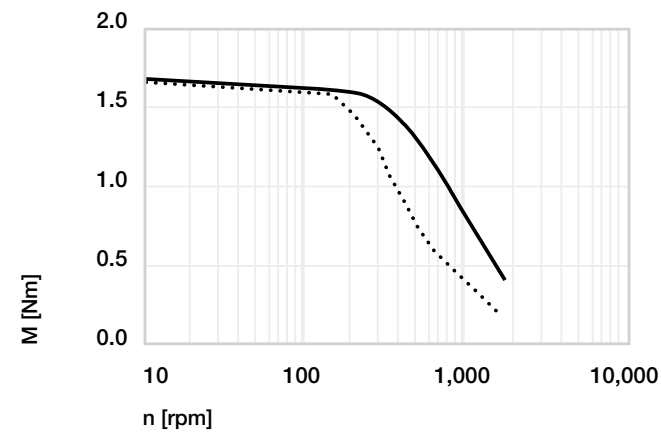

Flange size 56 (NEMA23)

MOT-AP-S-060-013-056-K-... (IP68 underwater)

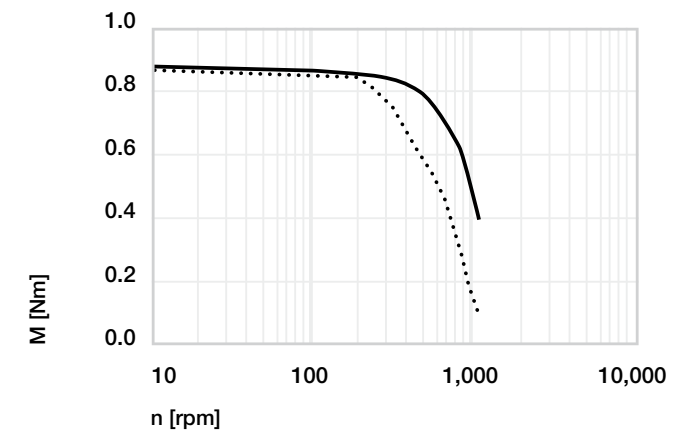

Flange size 56 (NEMA23)

MOT-AP-S-060-007-056-L-A-AAAJ (IP00 vacuum)

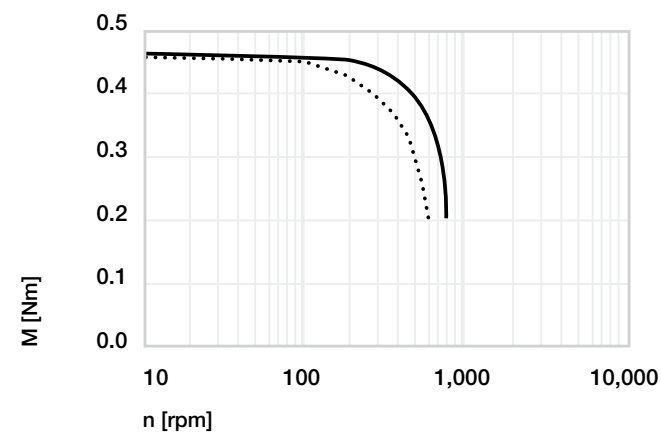

Flange size 42 (NEMA17)

MOT-ST-042-C-A-C

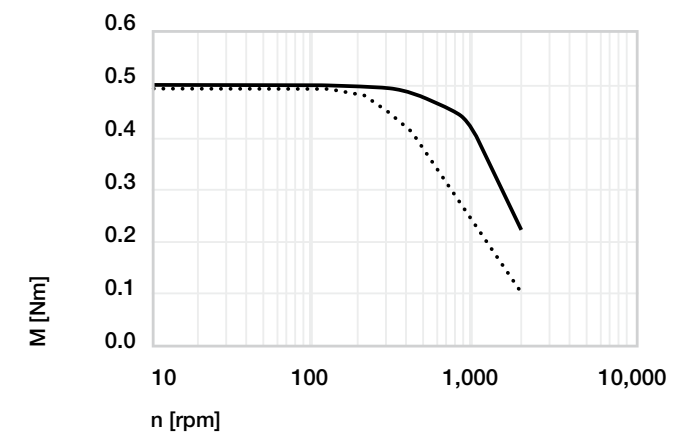

Flange size 56 (NEMA23)

MOT-ST-056-C-A-C

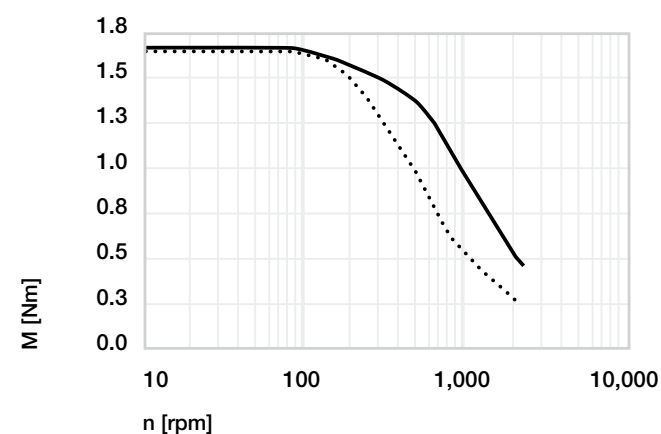

Flange size 60 (NEMA24)

MOT-ST-060-C-A-C

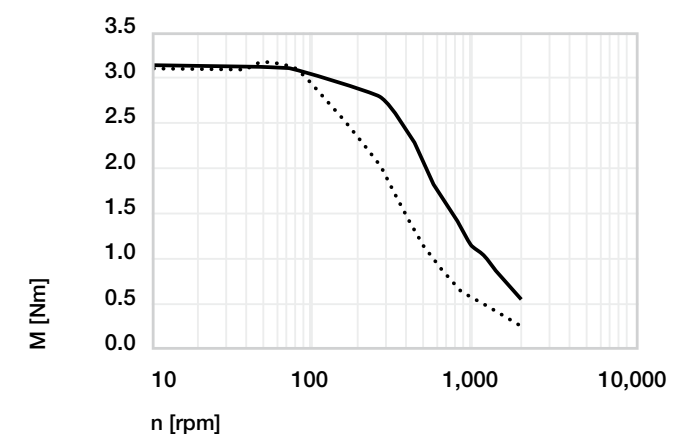

Flange size 86 (NEMA17) ► Page 639

----- 24VDC      ——— 48VDC

The characteristic curves are determined in quarter step mode



- Compatible with the most common motor controls
- Available in several installation sizes
- Short design
- Holding torque up to 1Nm
- Protection class: IP42
- Axial load up to 500N

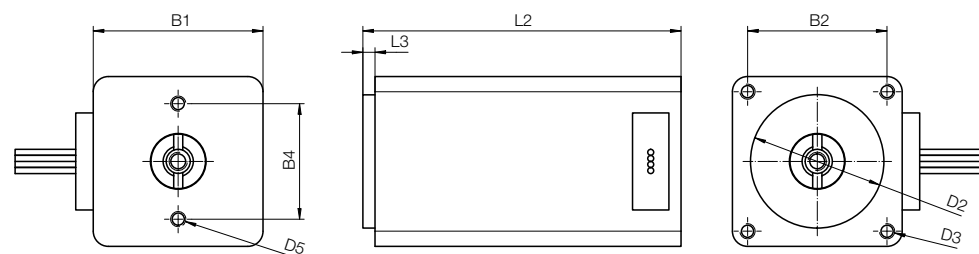

## Technical data

| Part No.        | Distance over hubs<br>[mm] | NEMA   | Connection        | Nominal current<br>[A] | Holding torque<br>[Nm] | Weight<br>[kg] |
|-----------------|----------------------------|--------|-------------------|------------------------|------------------------|----------------|
| MOT-ST-28-L-A-B | 28                         | NEMA11 | JST stranded wire | 0.67                   | 0.06                   | 0.11           |
| MOT-ST-42-L-A-B | 42                         | NEMA17 | JST stranded wire | 1.40                   | 0.20                   | 0.21           |
| MOT-ST-56-L-A-B | 56                         | NEMA23 | JST stranded wire | 2.80                   | 1.00                   | 0.63           |

## Dimensions [mm]

| Part No.        | L2   | L3  | D2     | B1   | B2    |
|-----------------|------|-----|--------|------|-------|
|                 | ±1.0 |     | ±0.025 |      | ±0.2  |
| MOT-ST-28-L-A-B | 31.5 | 2.0 | 22.0   | 28.2 | 23.0  |
| MOT-ST-42-L-A-B | 30.5 | 2.0 | 22.0   | 42.3 | 31.0  |
| MOT-ST-56-L-A-B | 50.0 | 1.6 | 38.1   | 56.4 | 47.14 |

 Further technical data, downloads and ordering options at ► [www.igus.eu/motors](http://www.igus.eu/motors)



- Compatible with the most common motor controls
- Available in several installation sizes
- Short design
- Holding torque up to 1Nm
- Protection class: IP42
- Axial load up to 500N
- Encoder with 500PPR

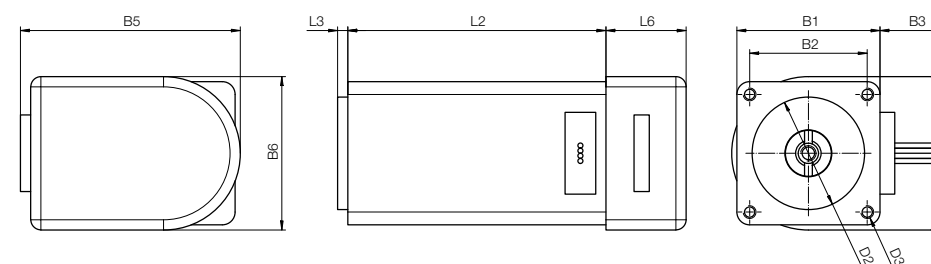

## Technical data

| Part No.        | Distance over hubs<br>[mm] | NEMA   | Connection        | Nominal current<br>[A] | Holding torque<br>[Nm] | Weight<br>[kg] |
|-----------------|----------------------------|--------|-------------------|------------------------|------------------------|----------------|
| MOT-ST-28-L-C-B | 28                         | NEMA11 | JST stranded wire | 0.67                   | 0.06                   | 0.13           |
| MOT-ST-42-L-C-B | 42                         | NEMA17 | JST stranded wire | 1.40                   | 0.20                   | 0.23           |
| MOT-ST-56-L-C-B | 56                         | NEMA23 | JST stranded wire | 2.80                   | 1.00                   | 0.65           |

## Dimensions [mm]

| Part No.        | L2   | L3  | L6   | D2   | B1   | B2    | B3   |
|-----------------|------|-----|------|------|------|-------|------|
|                 | ±1.0 |     |      |      |      | ±0.2  | ±0.2 |
| MOT-ST-28-L-C-B | 31.5 | 2.0 | 15.7 | 22.0 | 28.2 | 23.00 | 12.5 |
| MOT-ST-42-L-C-B | 30.5 | 2.0 | 15.7 | 22.0 | 42.3 | 31.00 | 6.0  |
| MOT-ST-56-L-C-B | 50.0 | 1.6 | 15.7 | 38.1 | 56.4 | 47.14 | –    |

 Further technical data, downloads and ordering options at ► [www.igus.eu/motors](http://www.igus.eu/motors)



- Compatible with the most common motor controls
- Available in several installation sizes
- Holding torque up to 2Nm
- Protection class: IP42
- Axial load up to 500N

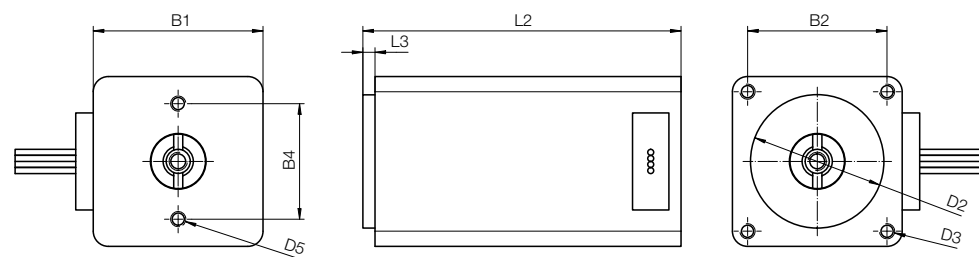

## Technical data

| Part No.        | Distance over hubs<br>[mm] | NEMA   | Connection        | Nominal current<br>[A] | Holding torque<br>[Nm] | Weight<br>[kg] |
|-----------------|----------------------------|--------|-------------------|------------------------|------------------------|----------------|
| MOT-ST-28-L-A-A | 28                         | NEMA11 | JST stranded wire | 1.0                    | 0.12                   | 0.25           |
| MOT-ST-42-L-A-A | 42                         | NEMA17 | JST stranded wire | 1.8                    | 0.50                   | 0.34           |
| MOT-ST-56-L-A-A | 56                         | NEMA23 | JST stranded wire | 4.2                    | 2.00                   | 1.00           |

## Dimensions [mm]

| Part No.        | L2<br>±1.0 | L3  | D2<br>±0.025 | B1   | B2<br>±0.2 |
|-----------------|------------|-----|--------------|------|------------|
| MOT-ST-28-L-A-A | 51         | 2.0 | 22.0         | 28.2 | 23.00      |
| MOT-ST-42-L-A-A | 49         | 2.0 | 22.0         | 42.3 | 31.00      |
| MOT-ST-56-L-A-A | 76         | 1.6 | 38.1         | 56.4 | 47.14      |

 Further technical data, downloads and ordering options at ► [www.igus.eu/motors](http://www.igus.eu/motors)



- Compatible with the most common motor controls
- Available in several installation sizes
- Holding torque up to 2Nm
- Protection class: IP42
- Axial load up to 500N
- Encoder with 500PPR

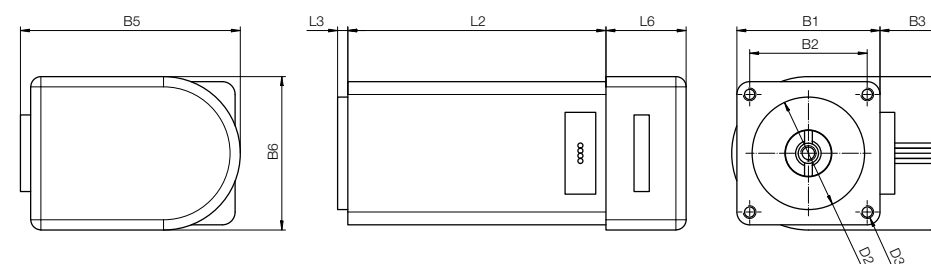

## Technical data

| Part No.        | Distance over hubs<br>[mm] | NEMA   | Connection        | Nominal current<br>[A] | Holding torque<br>[Nm] | Weight<br>[kg] |
|-----------------|----------------------------|--------|-------------------|------------------------|------------------------|----------------|
| MOT-ST-28-L-C-A | 28                         | NEMA11 | JST stranded wire | 1.0                    | 0.12                   | 0.27           |
| MOT-ST-42-L-C-A | 42                         | NEMA17 | JST stranded wire | 1.8                    | 0.50                   | 0.36           |
| MOT-ST-56-L-C-A | 56                         | NEMA23 | JST stranded wire | 4.2                    | 2.00                   | 1.02           |

## Dimensions [mm]

| Part No.        | L2<br>±1.0 | L3  | L6   | D2   | B1   | B2<br>±0.2 | B3<br>±0.2 |
|-----------------|------------|-----|------|------|------|------------|------------|
| MOT-ST-28-L-C-A | 51         | 2.0 | 15.2 | 22.0 | 28.2 | 23.00      | 12.5       |
| MOT-ST-42-L-C-A | 49         | 2.0 | 16.0 | 22.0 | 42.3 | 31.00      | 6.0        |
| MOT-ST-56-L-C-A | 76         | 1.6 | 16.0 | 38.1 | 56.4 | 47.14      | -          |

 Further technical data, downloads and ordering options at ► [www.igus.eu/motors](http://www.igus.eu/motors)



Flange size 28 (NEMA11)

MOT-ST-28-...

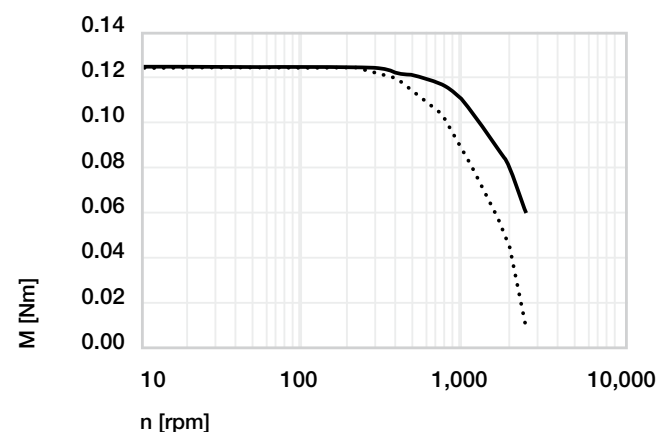

Flange size 28 (NEMA11)

MOT-ST-28-...

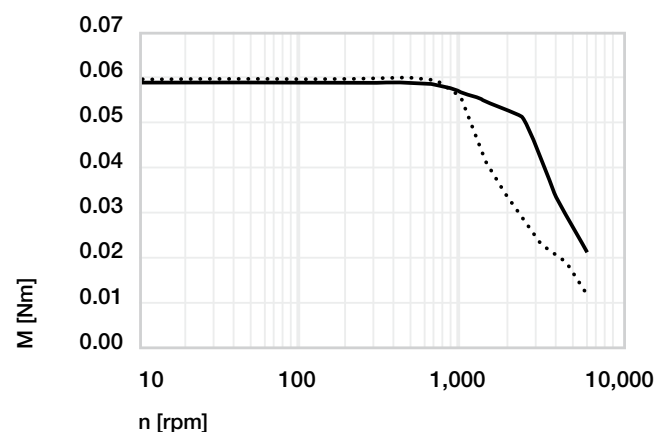

Flange size 42 (NEMA17)

MOT-ST-42-...

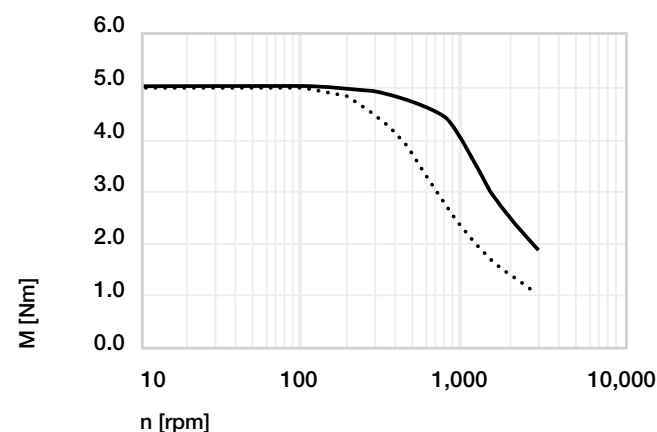

Flange size 42 (NEMA17)

MOT-ST-42-...

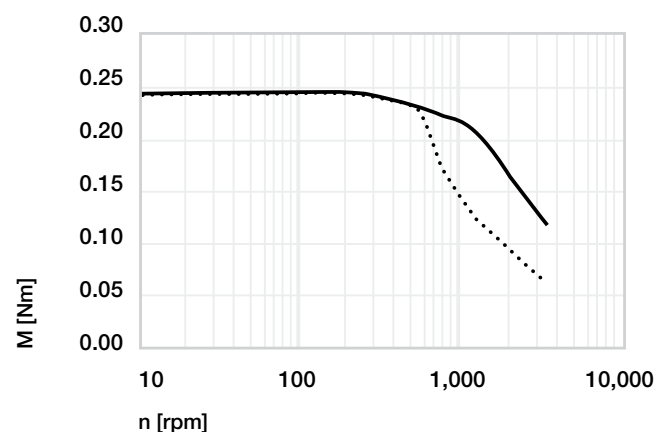

Flange size 56 (NEMA23)

MOT-ST-56-...

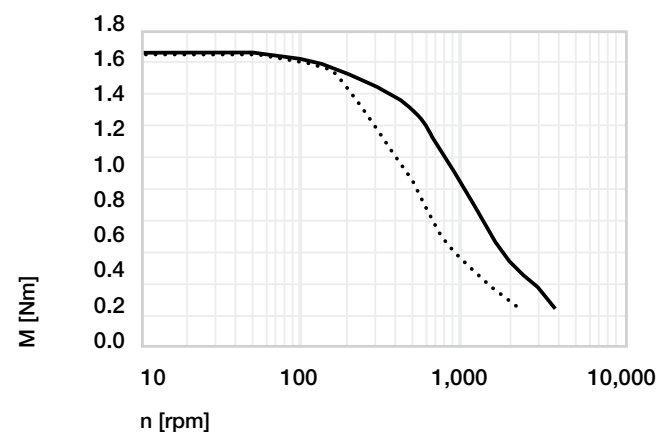

Flange size 56 (NEMA23)

MOT-ST-56-...

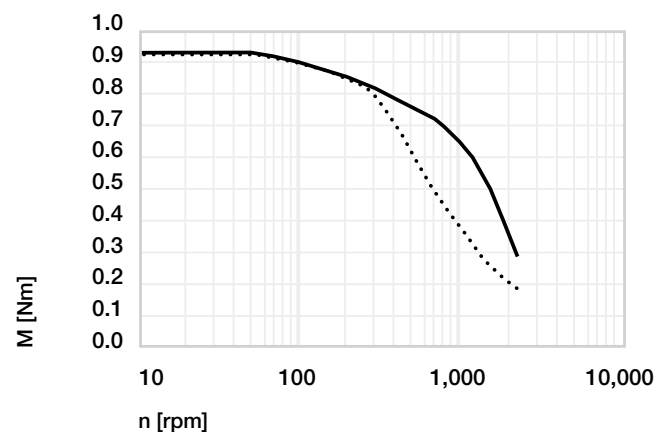

----- 24VDC      ——— 48VDC

The characteristic curves are determined in quarter step mode



- Compatible with the most common motor controls
- Available in several installation sizes
- Motor winding: 48 VDC
- Protection class: IP40
- Constant torque over the entire speed range

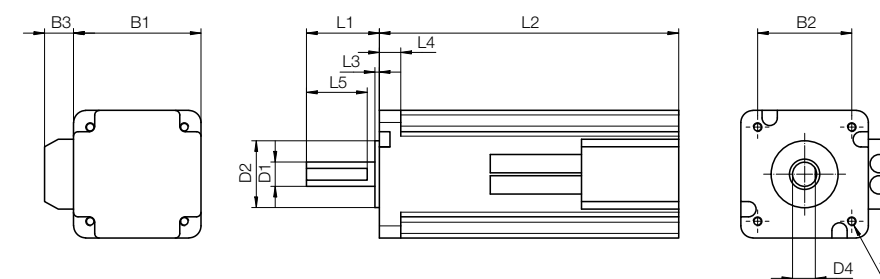

Technical data

| Part No.        | Distance over hubs [mm] | NEMA   | Connection  | Poles (pole pairs) | Nominal current [A] | Rated torque [Nm] | Weight [kg] |
|-----------------|-------------------------|--------|-------------|--------------------|---------------------|-------------------|-------------|
| MOT-EC-42-C-H-A | 42                      | NEMA17 | Molex cable | 8 (4)              | 2.6                 | 0.3               | 0.75        |
| MOT-EC-56-C-H-A | 56                      | NEMA23 | Molex cable | 8 (4)              | 5.0                 | 0.6               | 1.30        |
| MOT-EC-60-C-H-A | 60                      | NEMA24 | Molex cable | 8 (4)              | 7.5                 | 0.8               | 1.35        |
| MOT-EC-86-C-H-A | 86                      | NEMA34 | Molex cable | 8 (4)              | 8.7                 | 1.0               | 2.30        |

Dimensions [mm]

| Part No.        | L1   | L2   | D1     | D2     | B1   | B2    | B3 |
|-----------------|------|------|--------|--------|------|-------|----|
|                 | ±1.0 | ±1.0 | -0.013 | ±0.025 |      | ±0.2  |    |
| MOT-EC-42-C-H-A | 24   | 99.0 | 8      | 22.0   | 42.0 | 31.00 | 9  |
| MOT-EC-56-C-H-A | 21   | 98.0 | 8      | 38.1   | 56.4 | 47.14 | 9  |
| MOT-EC-60-C-H-A | 21   | 87.7 | 8      | 38.1   | 60.5 | 47.15 | 9  |
| MOT-EC-86-C-H-A | 35   | 80.5 | 14     | 73.0   | 86.0 | 69.60 | 9  |

Further technical data, downloads and ordering options at ► [www.igus.eu/motors](http://www.igus.eu/motors)



- Compatible with the most common motor controls
- Available in several installation sizes
- Encoder with 1,000PPR
- Motor winding: 48 VDC
- Protection class: IP40
- Constant torque over the entire speed range

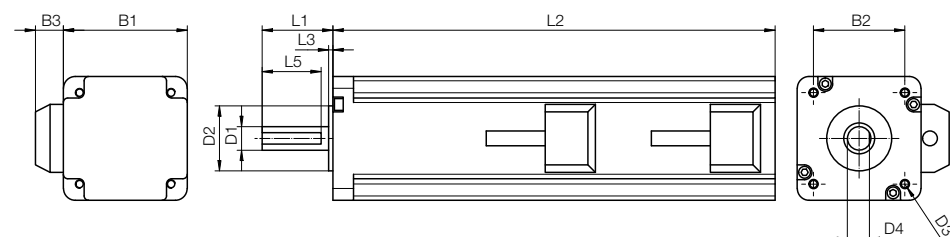

## Technical data

| Part No.        | Distance over hubs<br>[mm] | NEMA   | Connection  | Poles<br>(pole pairs) | Nominal current<br>[A] | Rated torque<br>[Nm] | Weight<br>[kg] |
|-----------------|----------------------------|--------|-------------|-----------------------|------------------------|----------------------|----------------|
| MOT-EC-42-C-I-A | 42                         | NEMA17 | Molex cable | 8 (4)                 | 2.6                    | 0.3                  | 0.8            |
| MOT-EC-56-C-I-A | 56                         | NEMA23 | Molex cable | 8 (4)                 | 5.0                    | 0.6                  | 1.4            |
| MOT-EC-60-C-I-A | 60                         | NEMA24 | Molex cable | 8 (4)                 | 7.5                    | 0.8                  | 1.4            |
| MOT-EC-86-C-I-A | 86                         | NEMA34 | Molex cable | 8 (4)                 | 8.7                    | 1.0                  | 2.5            |

## Dimensions [mm]

| Part No.        | L1<br>±1.0 | L2<br>±1.0 | D1<br>-0.013 | D2<br>±0.025 | B1   | B2<br>±0.2 | B3 |
|-----------------|------------|------------|--------------|--------------|------|------------|----|
| MOT-EC-42-C-I-A | 24         | 115.0      | 8            | 22.0         | 42.0 | 31.00      | 9  |
| MOT-EC-56-C-I-A | 21         | 115.0      | 8            | 38.1         | 56.4 | 47.14      | 9  |
| MOT-EC-60-C-I-A | 21         | 97.0       | 8            | 38.1         | 60.5 | 47.15      | 9  |
| MOT-EC-86-C-I-A | 35         | 110.5      | 14           | 73.0         | 86.0 | 69.60      | 9  |



- Compatible with the most common motor controls
- Available in several installation sizes
- Encoder with 1,000PPR
- Brake up to 1.5Nm holding torque
- Motor winding: 48 VDC
- Protection class: IP40
- Constant torque over the entire speed range

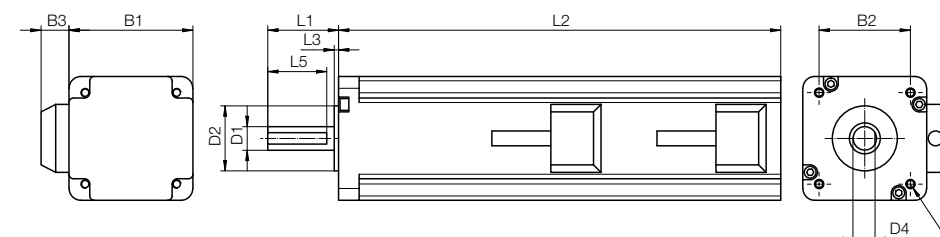

## Technical data

| Part No.        | Distance over hubs<br>[mm] | NEMA   | Connection  | Poles<br>(pole pairs) | Nominal current<br>[A] | Rated torque<br>[Nm] | Brake holding torque<br>[Nm] | Weight<br>[kg] |
|-----------------|----------------------------|--------|-------------|-----------------------|------------------------|----------------------|------------------------------|----------------|
| MOT-EC-42-C-K-A | 42                         | NEMA17 | Molex cable | 8 (4)                 | 2.6                    | 0.3                  | 0.5                          | 0.95           |
| MOT-EC-56-C-K-A | 56                         | NEMA23 | Molex cable | 8 (4)                 | 5.0                    | 0.6                  | 1.5                          | 1.70           |
| MOT-EC-60-C-K-A | 60                         | NEMA24 | Molex cable | 8 (4)                 | 7.5                    | 0.8                  | 1.5                          | 1.50           |
| MOT-EC-86-C-K-A | 86                         | NEMA34 | Molex cable | 8 (4)                 | 8.7                    | 1.0                  | 1.5                          | 3.10           |

## Dimensions [mm]

| Part No.        | L1<br>±1.0 | L2<br>±1.0 | D1<br>-0.013 | D2<br>±0.025 | B1   | B2<br>±0.2 | B3 |
|-----------------|------------|------------|--------------|--------------|------|------------|----|
| MOT-EC-42-C-K-A | 24         | 149        | 8            | 22.0         | 42.0 | 31.00      | 9  |
| MOT-EC-56-C-K-A | 21         | 149        | 8            | 38.1         | 56.4 | 47.14      | 9  |
| MOT-EC-60-C-K-A | 21         | 130        | 8            | 38.1         | 60.5 | 47.15      | 9  |
| MOT-EC-86-C-K-A | 35         | 151        | 14           | 73.0         | 86.0 | 69.60      | 9  |

## Flange size 42 (NEMA17)

MOT-EC-42-...

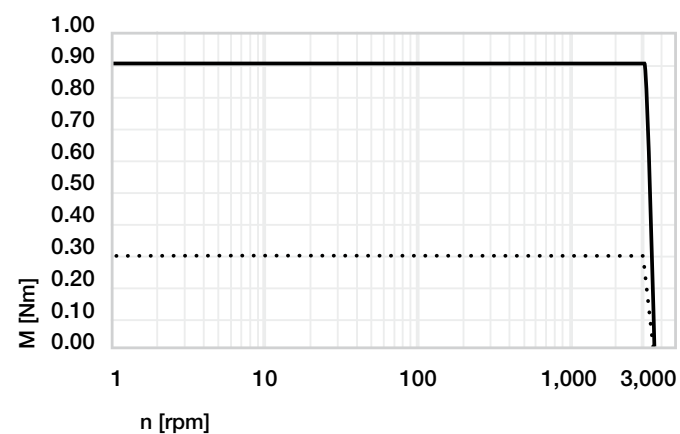

## Flange size 56 (NEMA23)

MOT-EC-56-...

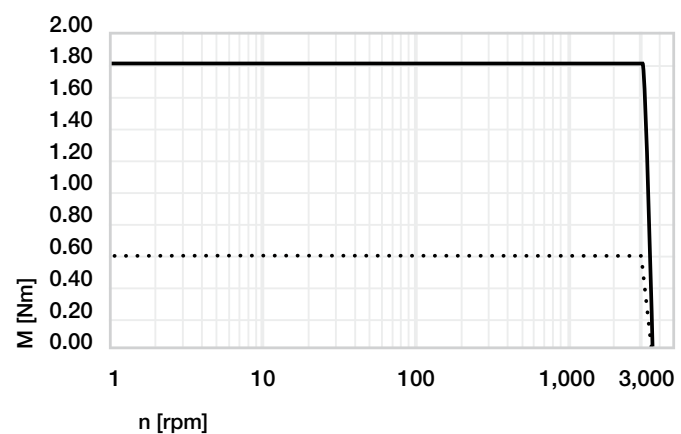

## Flange size 60 (NEMA24)

MOT-EC-60-...

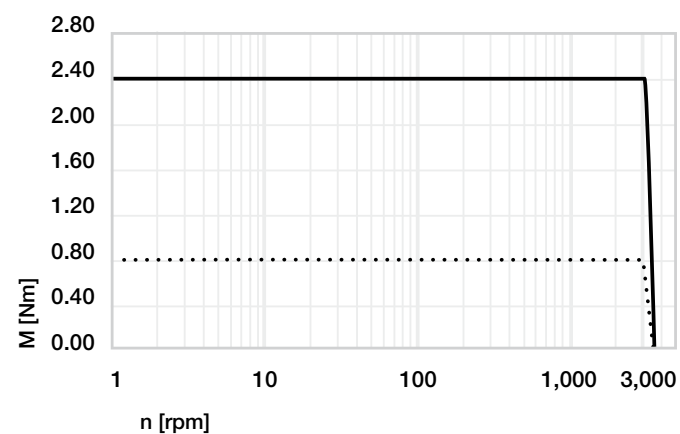

## Flange size 86 (NEMA34)

MOT-EC-86-...

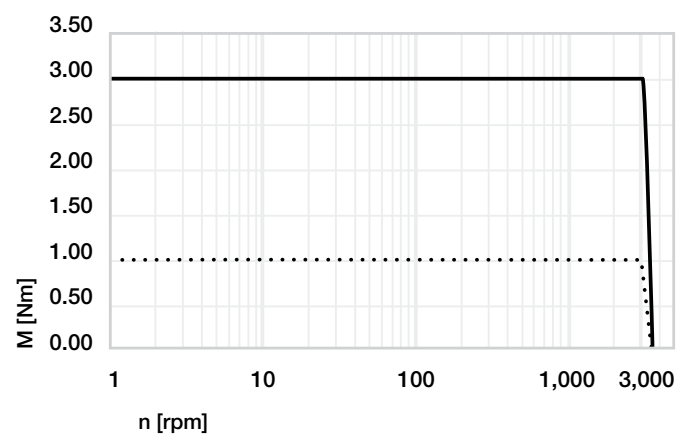

----- 48VDC nominal    ——— 48VDC peak

The characteristic curves are determined in quarter step mode



- Compatible with the most common motor controls
- Available in several installation sizes
- Rated torque up to 1.8Nm
- Protection class: IP40 to IP52

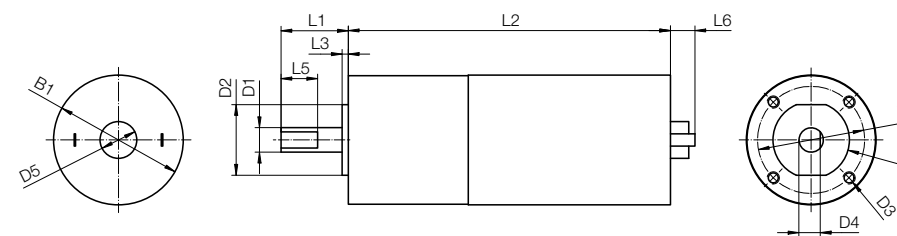

## Technical data

| Part No.                      | Distance over hubs [mm] | Connection     | Nominal current [A] | Rated torque [Nm] | Start up torque [Nm] | Weight [kg] |
|-------------------------------|-------------------------|----------------|---------------------|-------------------|----------------------|-------------|
| MOT-DC-22-F-A-D               | 22                      | Flat connector | 0.15                | 0.025             | 0.13                 | 0.062       |
| MOT-DC-22-F-A-E               | 22                      | Flat connector | 0.15                | 0.060             | 0.35                 | 0.067       |
| MOT-DC-22-F-A-J               | 22                      | Flat connector | 0.15                | 0.210             | 1.18                 | 0.092       |
| MOT-AE-B-024-005-036-F-A-AAAA | 36                      | Flat connector | 0.90                | 0.500             | 1.00                 | 0.450       |
| MOT-AE-B-024-010-042-F-A-AAAA | 42                      | Flat connector | 2.30                | 1.000             | 3.00                 | 0.650       |
| MOT-AE-B-024-018-042-F-A-AAAA | 42                      | Flat connector | 2.00                | 1.800             | 6.00                 | 0.690       |

## Dimensions [mm]

| Part No.                      | L1   | L2    | L6   | D1     | D2     | B1   | B2   |
|-------------------------------|------|-------|------|--------|--------|------|------|
|                               |      | ±1.0  |      | -0.013 | ±0.025 | ±0.3 | ±0.2 |
| MOT-DC-22-F-A-D               | 14.0 | 50.1  | 4.5  | 4      | 14     | 22.0 | 18   |
| MOT-DC-22-F-A-E               | 14.0 | 53.8  | 4.5  | 4      | 14     | 22.0 | 18   |
| MOT-DC-22-F-A-J               | 14.0 | 57.4  | 4.6  | 4      | 14     | 22.0 | 18   |
| MOT-AE-B-024-005-036-F-A-AAAA | 19.3 | 85.6  | 13.5 | 6      | 20     | 36.0 | 26   |
| MOT-AE-B-024-010-042-F-A-AAAA | 22.0 | 105.2 | 13.5 | 8      | 25     | 42.4 | 35   |
| MOT-AE-B-024-018-042-F-A-AAAA | 22.0 | 111.9 | 13.5 | 8      | 25     | 42.4 | 35   |

Further technical data, downloads and ordering options at ► [www.igus.eu/motors](http://www.igus.eu/motors)



- Compatible with the most common motor controls
- Available in several installation sizes
- Rated torque up to 1.5Nm
- Protection class: IP30

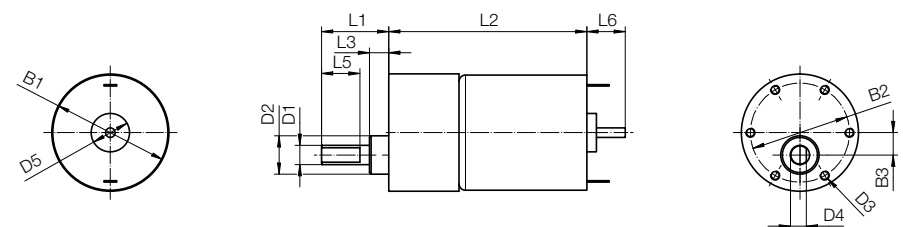

## Technical data

| Part No.                      | Distance over hubs [mm] | Connection     | Nominal current [A] | Rated torque [Nm] | Start up torque [Nm] | Weight [kg] |
|-------------------------------|-------------------------|----------------|---------------------|-------------------|----------------------|-------------|
| MOT-AE-B-024-001-037-F-A-AAAA | 37                      | Flat connector | 0.5                 | 0.1               | 0.3                  | 0.207       |
| MOT-AE-B-024-003-037-F-A-AAAA | 37                      | Flat connector | 0.5                 | 0.3               | 0.5                  | 0.213       |
| MOT-AE-B-024-007-037-F-A-AAAA | 37                      | Flat connector | 0.5                 | 0.7               | 1.0                  | 0.221       |
| MOT-AE-B-024-015-037-F-A-AAAA | 37                      | Flat connector | 0.5                 | 1.5               | 1.8                  | 0.270       |

## Dimensions [mm]

| Part No.                      | L1 | L2   | L6 | D1     | D2     | B1   | B2   |
|-------------------------------|----|------|----|--------|--------|------|------|
|                               |    | ±1.0 |    | -0.013 | ±0.025 | ±0.3 | ±0.3 |
| MOT-AE-B-024-001-037-F-A-AAAA | 21 | 59.5 | 12 | 6      | 12     | 37   | 31   |
| MOT-AE-B-024-003-037-F-A-AAAA | 21 | 62.0 | 12 | 6      | 12     | 37   | 31   |
| MOT-AE-B-024-007-037-F-A-AAAA | 21 | 64.5 | 12 | 6      | 12     | 37   | 31   |
| MOT-AE-B-024-015-037-F-A-AAAA | 21 | 67.0 | 12 | 6      | 12     | 37   | 31   |

Further technical data, downloads and ordering options at ► [www.igus.eu/motors](http://www.igus.eu/motors)

## Characteristic curves 24VDC

MOT-DC-22-F-A-D

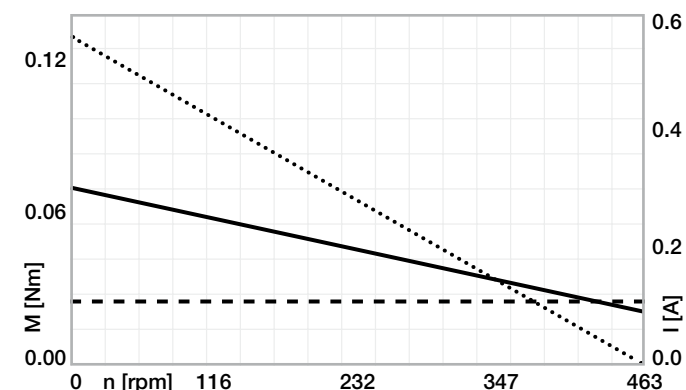

MOT-DC-22-F-A-E

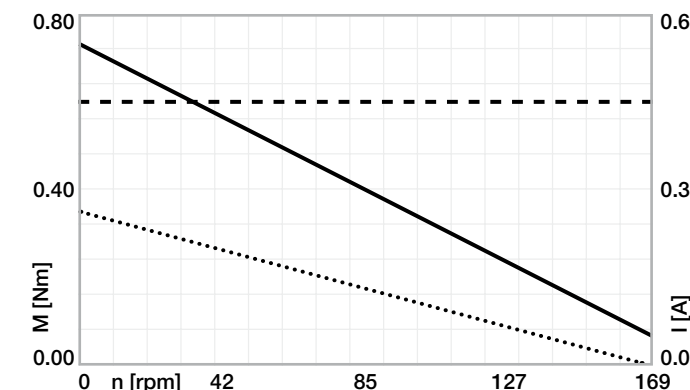

MOT-DC-22-F-A-J

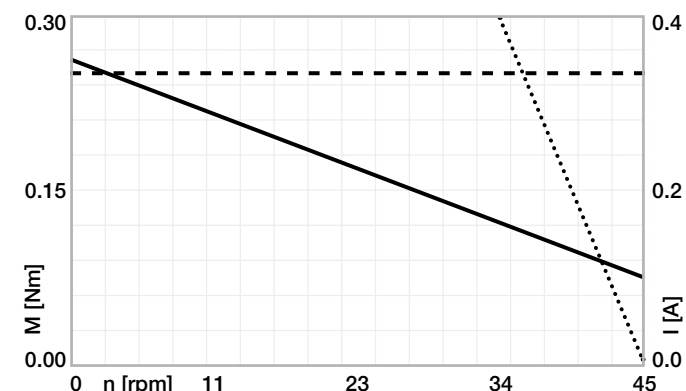

## Characteristic curves 12VDC

MOT-DC-22-F-A-D

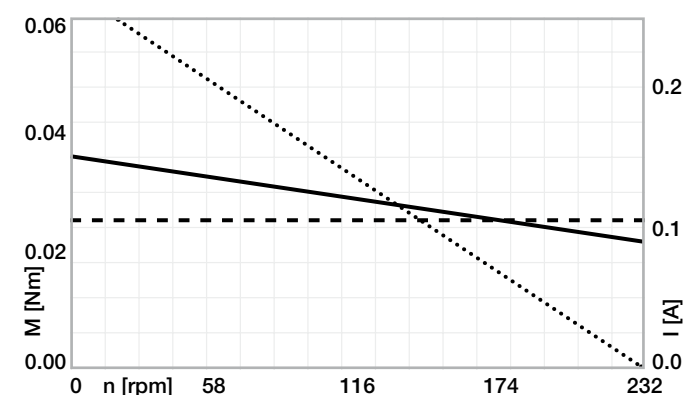

MOT-DC-22-F-A-E

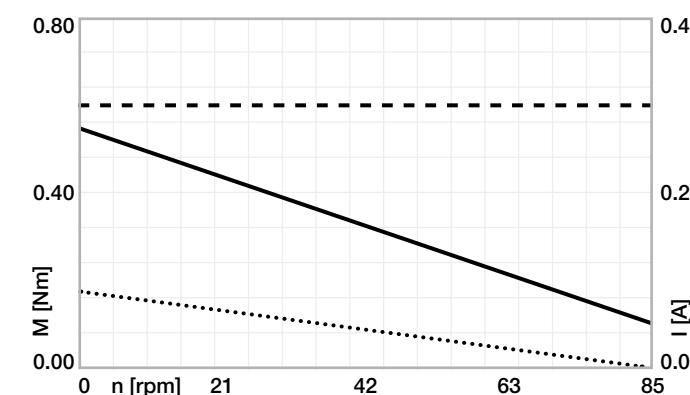

----- Torque    ----- Max. continuous torque    ——— Motor current





- Compatible with the most common motor controls
- Available in several installation sizes
- Rated torque up to 1.5Nm
- Protection class: IP41

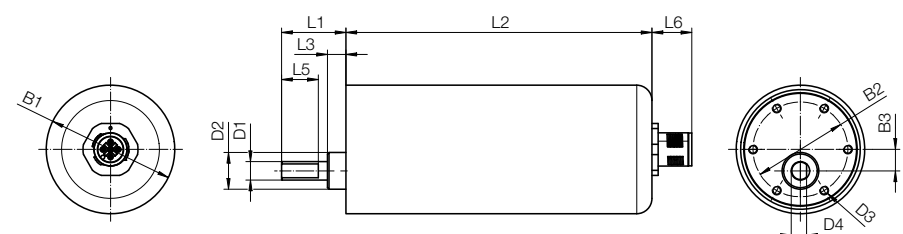

## Technical data

| Part No.        | Distance over hubs<br>[mm] | Connection | Nominal current<br>[A] | Rated torque<br>[Nm] | Start up torque<br>[Nm] | Weight<br>[kg] |
|-----------------|----------------------------|------------|------------------------|----------------------|-------------------------|----------------|
| MOT-DC-37-M-A-A | 37                         | Metric     | 0.5                    | 0.1                  | 0.3                     | 0.28           |
| MOT-DC-37-M-A-B | 37                         | Metric     | 0.5                    | 0.3                  | 0.5                     | 0.28           |
| MOT-DC-37-M-A-D | 37                         | Metric     | 0.5                    | 0.7                  | 1.0                     | 0.28           |
| MOT-DC-37-M-A-H | 37                         | Metric     | 0.5                    | 1.5                  | 1.8                     | 0.28           |

## Dimensions [mm]

| Part No.        | L1 | L2   | L6 | D1     | D2     | B1   | B2   |
|-----------------|----|------|----|--------|--------|------|------|
|                 |    | ±1.0 |    | -0.013 | ±0.025 | ±0.3 | ±0.2 |
| MOT-DC-37-M-A-A | 21 | 100  | 13 | 6.0    | 12.0   | 42.0 | 31.0 |
| MOT-DC-37-M-A-B | 21 | 100  | 13 | 6.0    | 12.0   | 42.0 | 31.0 |
| MOT-DC-37-M-A-D | 21 | 100  | 13 | 6.0    | 12.0   | 42.0 | 31.0 |
| MOT-DC-37-M-A-H | 21 | 100  | 13 | 6.0    | 12.0   | 42.0 | 31.0 |

 Further technical data, downloads and ordering options at ► [www.igus.eu/motors](http://www.igus.eu/motors)



- Compatible with the most common motor controls
- Available in several installation sizes
- Rated torque up to 1.8Nm
- Protection class: IP41

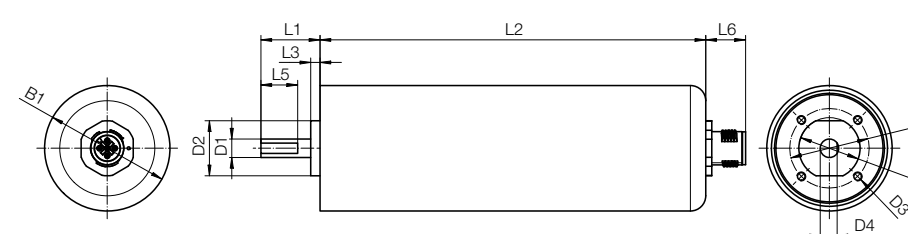

## Technical data

| Part No.        | Distance over hubs<br>[mm] | Connection | Nominal current<br>[A] | Rated torque<br>[Nm] | Start up torque<br>[Nm] | Weight<br>[kg] |
|-----------------|----------------------------|------------|------------------------|----------------------|-------------------------|----------------|
| MOT-DC-36-M-A-D | 36                         | Metric     | 0.9                    | 0.5                  | 1.0                     | 0.42           |
| MOT-DC-42-M-A-D | 42                         | Metric     | 2.3                    | 1.0                  | 3.0                     | 0.58           |
| MOT-DC-42-M-A-F | 42                         | Metric     | 2.0                    | 1.8                  | 6.0                     | 0.58           |

## Dimensions [mm]

| Part No.        | L1   | L2   | L6 | D1     | D2     | B1   | B2   |
|-----------------|------|------|----|--------|--------|------|------|
|                 |      | ±1.0 |    | -0.013 | ±0.025 | ±0.3 | ±0.2 |
| MOT-DC-36-M-A-D | 19.3 | 126  | 13 | 6.0    | 20.0   | 41.0 | 26   |
| MOT-DC-42-M-A-D | 22.0 | 146  | 13 | 8.0    | 25.0   | 47.3 | 35   |
| MOT-DC-42-M-A-F | 22.0 | 146  | 13 | 8.0    | 25.0   | 47.3 | 35   |

 Further technical data, downloads and ordering options at ► [www.igus.eu/motors](http://www.igus.eu/motors)

Characteristic curves 24VDC

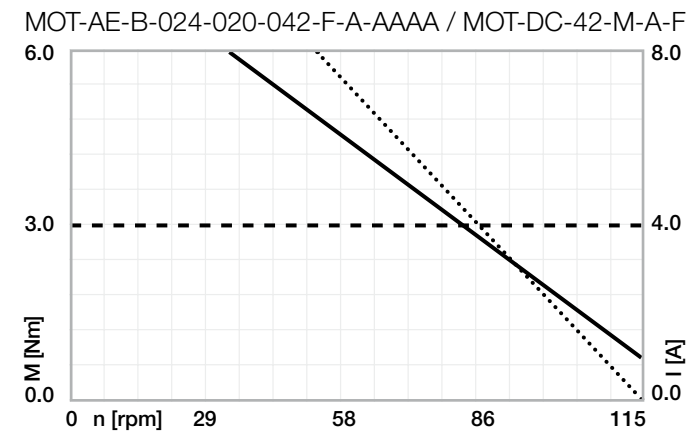
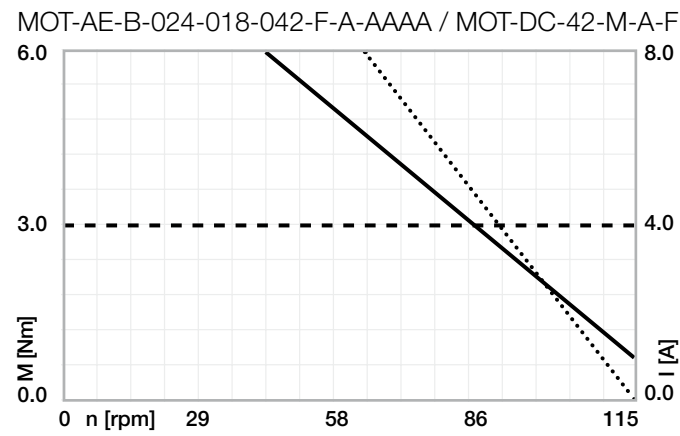
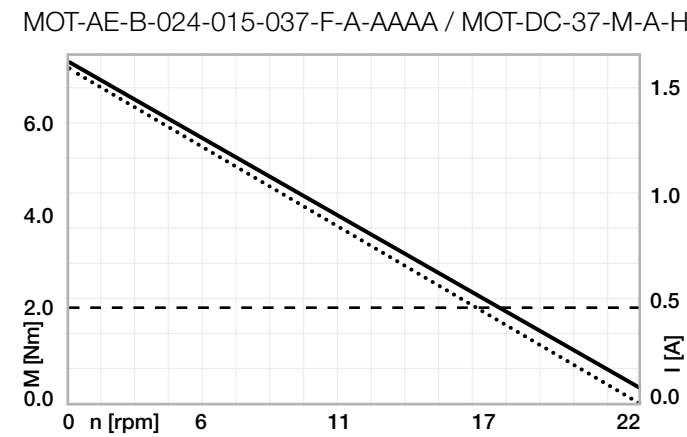
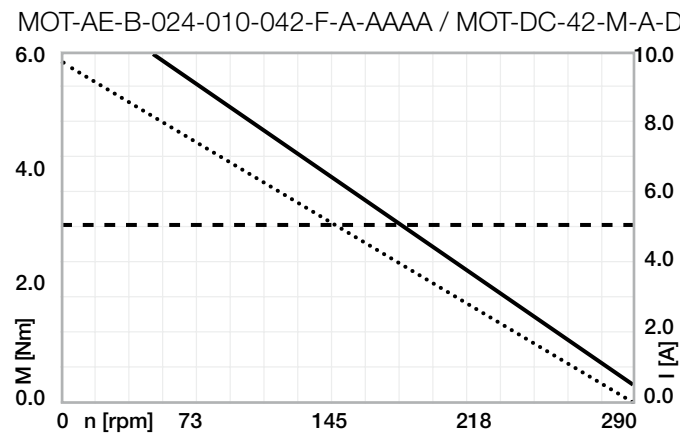
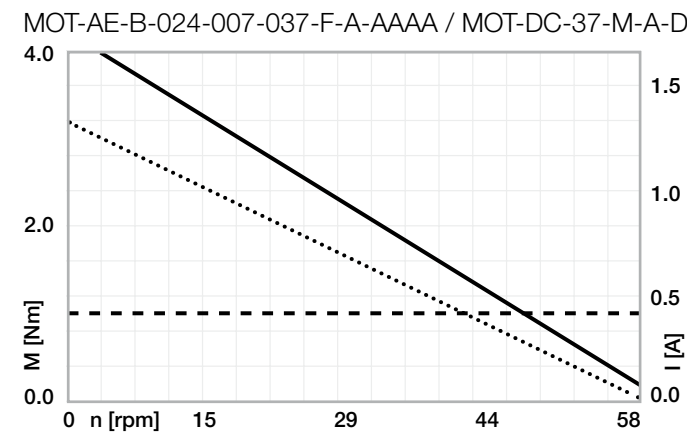
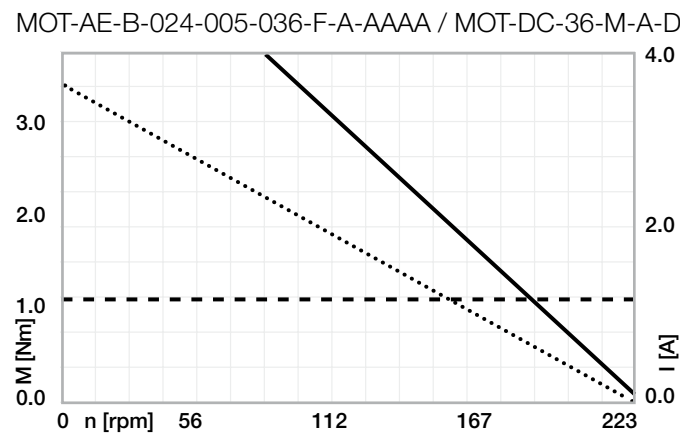
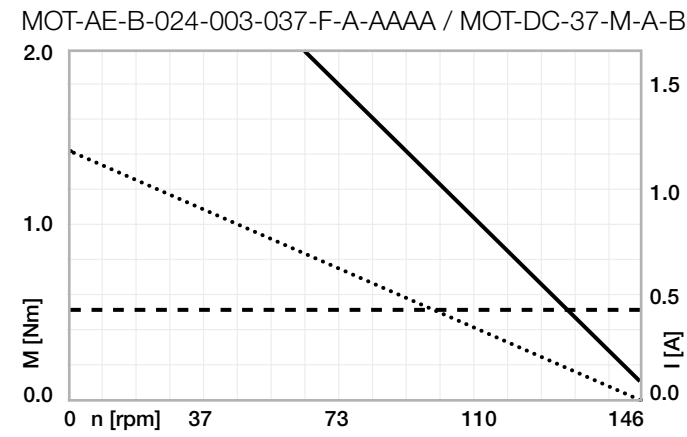
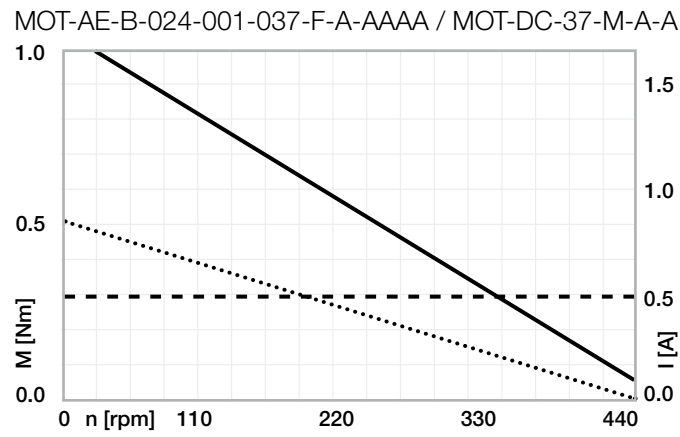

----- Torque    ----- Max. continuous torque    —— Motor current

Characteristic curves 12VDC

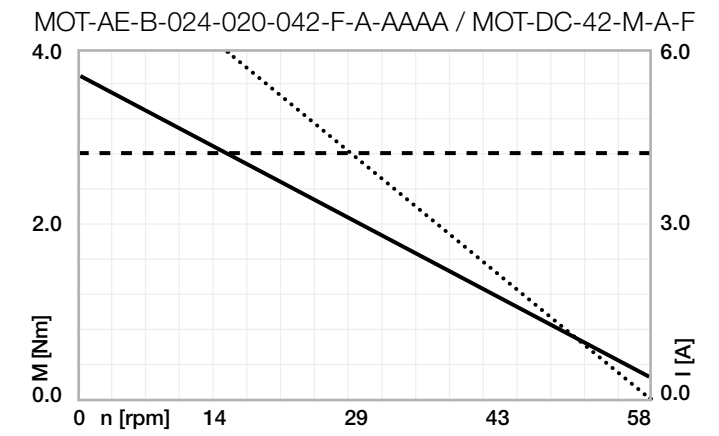
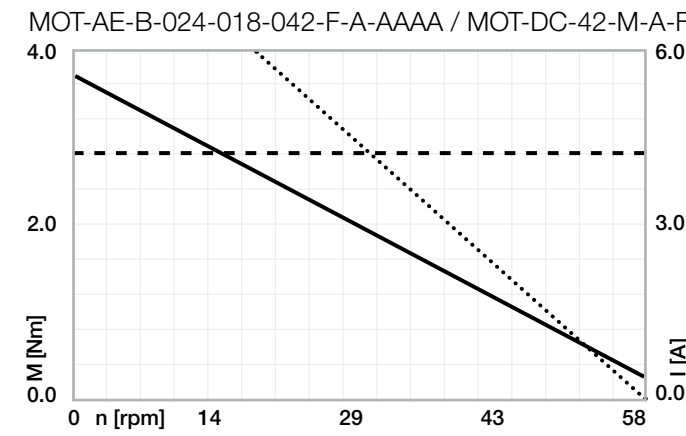
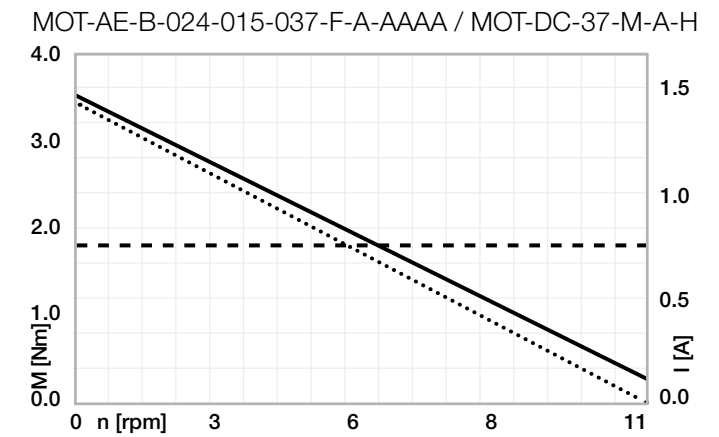
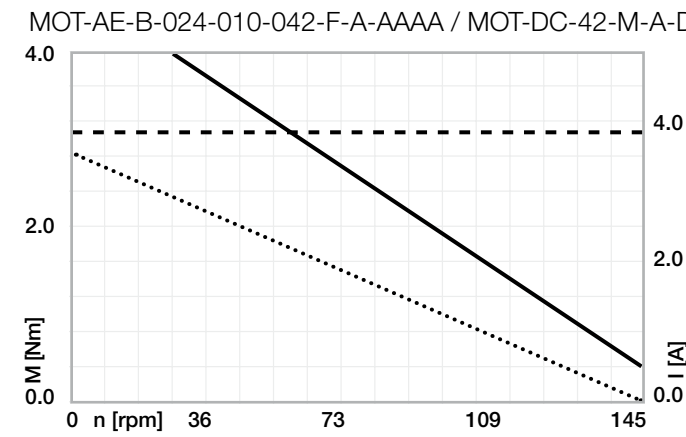
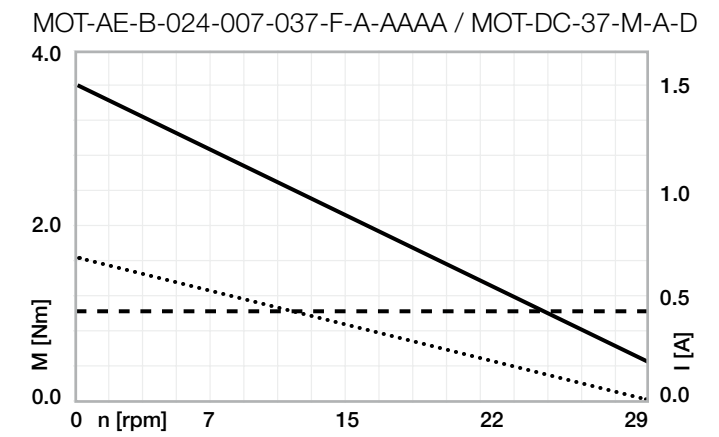
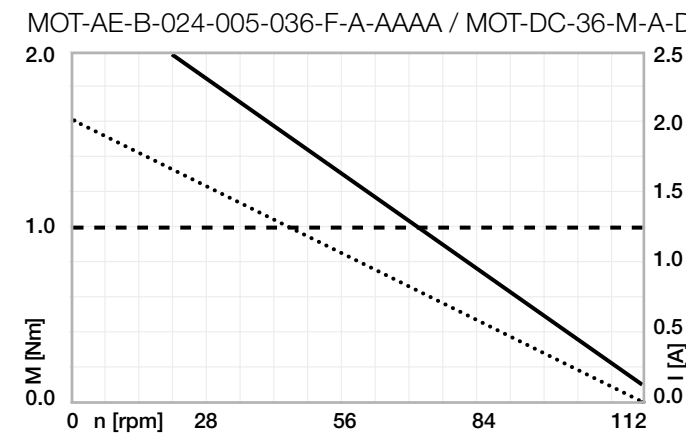
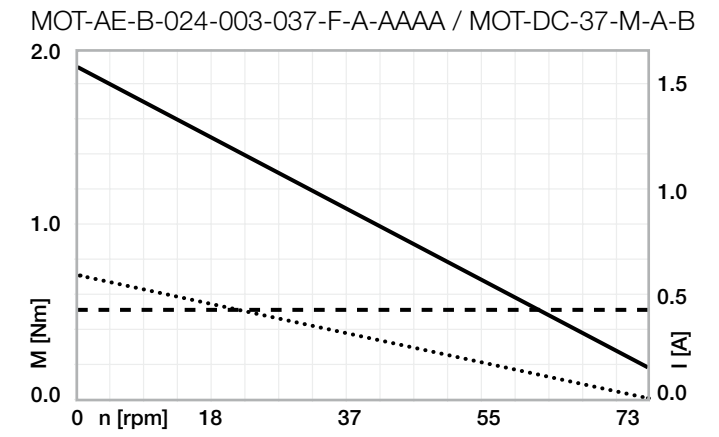
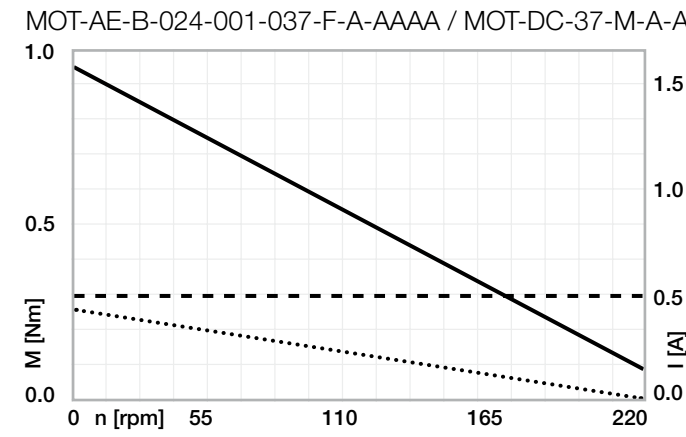

----- Torque    ----- Max. continuous torque    —— Motor current



- Compatible with the most common motor controls
- Available in several installation sizes
- High torque with small motors
- Protection class: IP41
- Space-saving in conjunction with drive technology

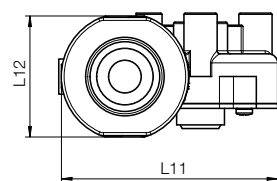
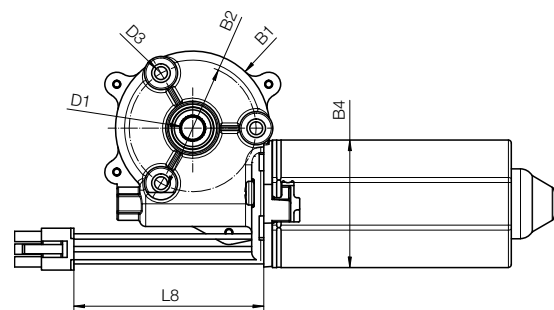
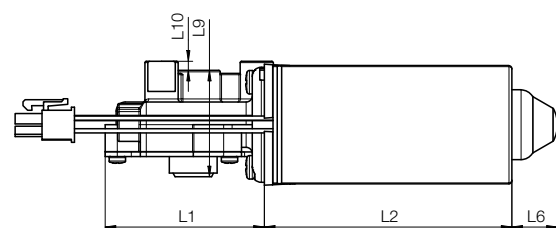

Technical data

| Part No.                   | Distance over hubs [mm] | Connection          | Nominal current [A] | Rated torque [Nm] | Start up torque [Nm] | Weight [kg] |
|----------------------------|-------------------------|---------------------|---------------------|-------------------|----------------------|-------------|
| MOT-DC-42-J-H-B <b>New</b> | 42                      | Molex stranded wire | 1.5                 | 2.00              | 10.0                 | 0.7         |
| MOT-DC-42-J-H-D <b>New</b> | 42                      | Molex stranded wire | 2.8                 | 1.75              | 8.0                  | 0.7         |
| MOT-DC-42-J-H-F <b>New</b> | 42                      | Molex stranded wire | 1.9                 | 1.25              | 7.5                  | 0.7         |
| MOT-DC-42-J-H-H <b>New</b> | 42                      | Molex stranded wire | 1.9                 | 0.75              | 5.0                  | 0.7         |
| MOT-DC-42-J-H-J <b>New</b> | 42                      | Molex stranded wire | 4.0                 | 3.00              | 18.0                 | 0.7         |
| MOT-DC-42-J-H-L <b>New</b> | 42                      | Molex stranded wire | 4.0                 | 2.50              | 13.0                 | 0.7         |
| MOT-DC-42-J-H-N <b>New</b> | 42                      | Molex stranded wire | 5.0                 | 1.60              | 7.0                  | 0.7         |
| MOT-DC-42-J-H-P <b>New</b> | 42                      | Molex stranded wire | 4.0                 | 1.40              | 9.0                  | 0.7         |

Dimensions [mm]

| Part No.                   | L1 | L2    | L6    | L8 | D1  | D2 | B1 | B2          |
|----------------------------|----|-------|-------|----|-----|----|----|-------------|
| MOT-DC-42-J-H-□ <b>New</b> | 55 | 81.65 | 15.97 | 42 | 7x8 | M5 | 51 | 42 (3x120°) |

**i** dryspin® motor lead screw with spline  
▶ Page 392

**m** Further technical data, downloads and ordering options at ▶ [www.igus.eu/motors](http://www.igus.eu/motors)

Characteristic curves 24VDC

MOT-DC-42-J-H-B

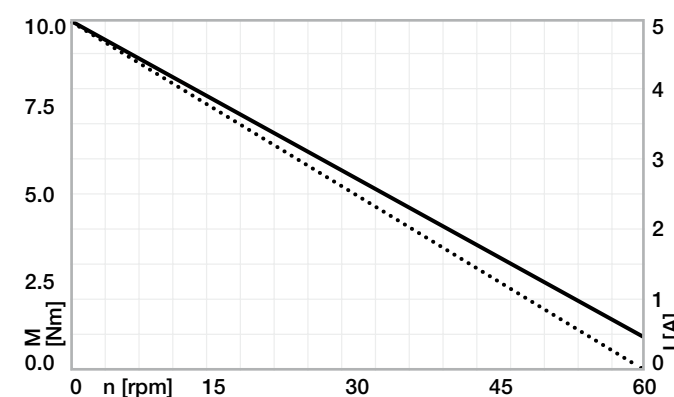

MOT-DC-42-J-H-D

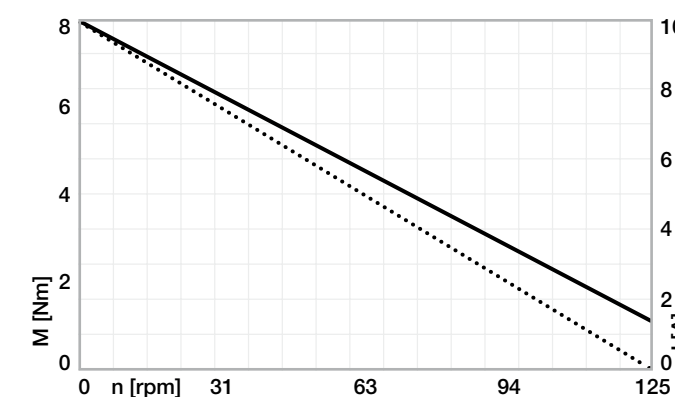

MOT-DC-42-J-H-F

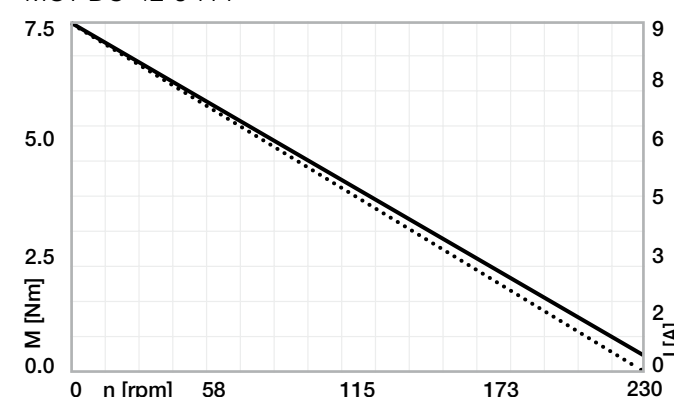

MOT-DC-42-J-H-H

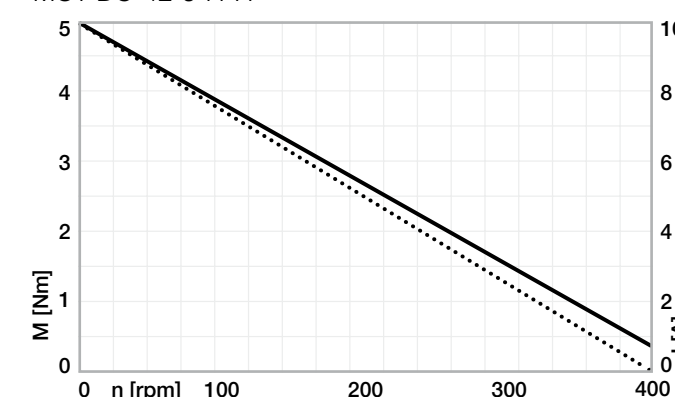

MOT-DC-42-J-H-J

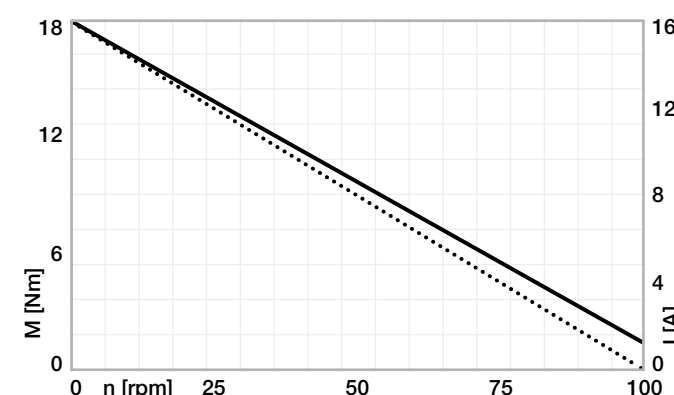

MOT-DC-42-J-H-L

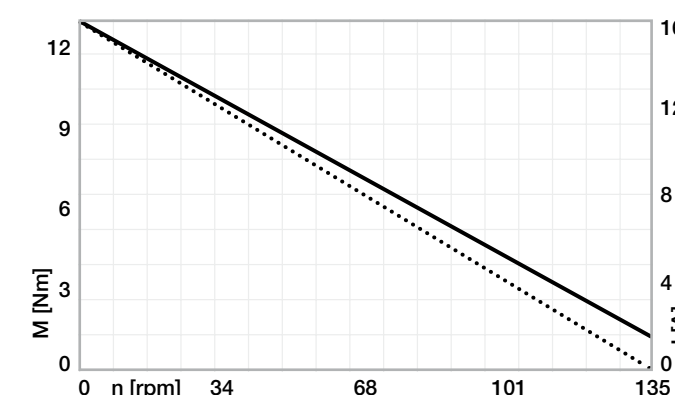

MOT-DC-42-J-H-N

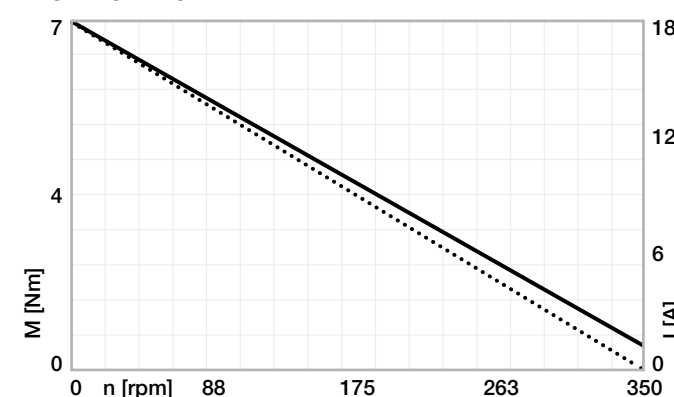

MOT-DC-42-J-H-P

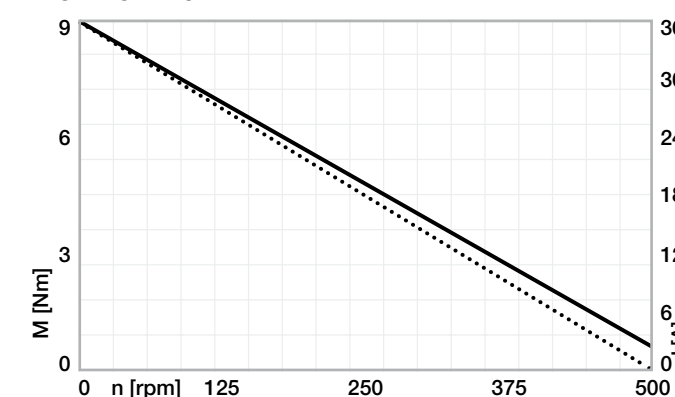

----- Torque      ——— Motor current

## Linear actuator



- Compatible with the most common motor controls
- Available in three installation sizes
- Holding torque up to 2Nm
- Protection class: IP40
- Axial load up to 500N
- Integrated lead screw and nut

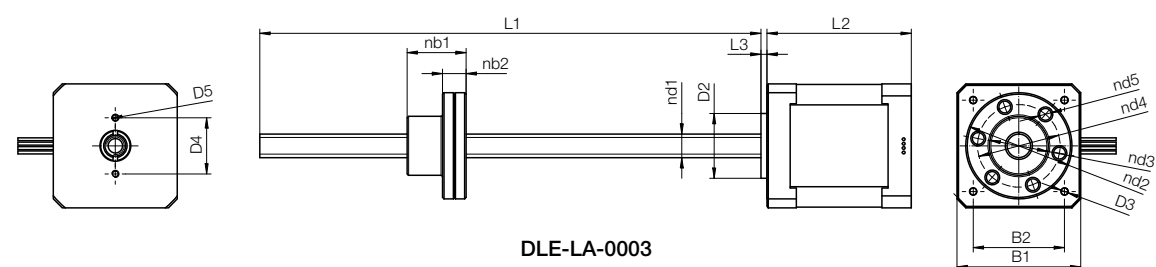

DLE-LA-0003

## Technical data

| Part No.    | Distance over hubs [mm] | NEMA   | Connection    | Nominal current [A] | Holding torque [Nm] | Max. Axial force [N] | dryspin® technology | Weight [kg] |
|-------------|-------------------------|--------|---------------|---------------------|---------------------|----------------------|---------------------|-------------|
| DLE-LA-0001 | 28                      | NEMA11 | Stranded wire | 1.0                 | 0.12                | 50                   | Ds6.35x5.08         | 0.225       |
| DLE-LA-0003 | 42                      | NEMA17 | Stranded wire | 1.8                 | 0.50                | 100                  | Ds8x15              | 0.44        |
| DLE-LA-0005 | 56                      | NEMA23 | Stranded wire | 4.2                 | 2.00                | 500                  | Ds10x12             | 1.18        |

## Dimensions [mm]

| Part No.    | L2 ±1.0 | L3  | D2 ±0.025 | B1   | B2 ±0.2 | Usable stroke |
|-------------|---------|-----|-----------|------|---------|---------------|
| DLE-LA-0001 | 51      | 2.0 | 22.0      | 28.2 | 23.00   | 100           |
| DLE-LA-0003 | 49      | 2.0 | 22.0      | 42.3 | 31.00   | 150           |
| DLE-LA-0005 | 76      | 1.6 | 38.1      | 56.4 | 47.14   | 200           |

 dryspin® lead screws with precision machined ends ► Page 391

 Further technical data, downloads and ordering options at ► [www.igus.eu/motors](http://www.igus.eu/motors)

## Linear actuator with encoder

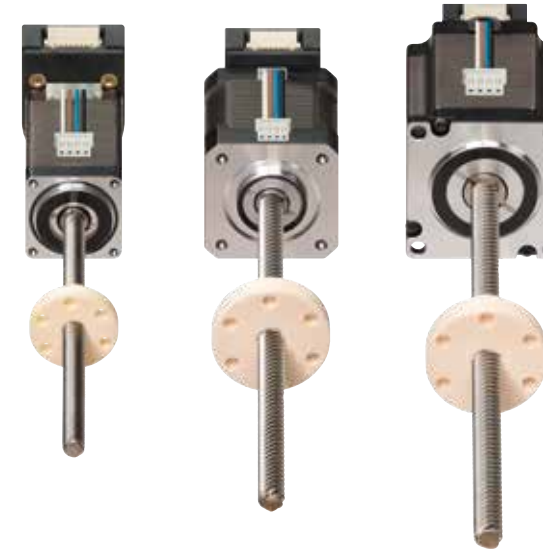

- Compatible with the most common motor controls
- Available in several installation sizes
- Holding torque up to 2Nm
- Protection class: IP40
- Axial load up to 500N
- Integrated lead screw and nut

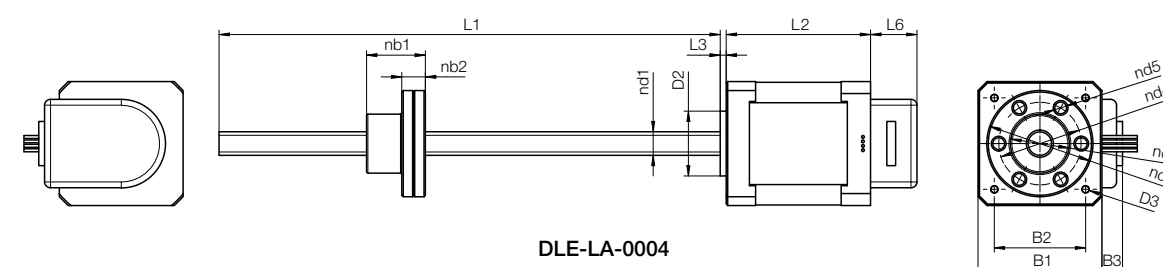

DLE-LA-0004

## Technical data

| Part No.    | Distance over hubs [mm] | NEMA   | Connection    | Nominal current [A] | Holding torque [Nm] | Max. Axial force [N] | dryspin® technology | Weight [kg] |
|-------------|-------------------------|--------|---------------|---------------------|---------------------|----------------------|---------------------|-------------|
| DLE-LA-0002 | 28                      | NEMA11 | Stranded wire | 1.0                 | 0.12                | 50                   | Ds6.35x5.08         | 0.245       |
| DLE-LA-0004 | 42                      | NEMA17 | Stranded wire | 1.8                 | 0.50                | 100                  | Ds8x15              | 0.46        |
| DLE-LA-0006 | 56                      | NEMA23 | Stranded wire | 4.2                 | 2.00                | 500                  | Ds10x12             | 1.20        |

## Dimensions [mm]

| Part No.    | L2 ±1.0 | L3  | L6   | D2 ±0.025 | B1   | B2 ±0.2 | Usable stroke |
|-------------|---------|-----|------|-----------|------|---------|---------------|
| DLE-LA-0002 | 51      | 2.0 | 15.2 | 22.0      | 28.2 | 23.00   | 100           |
| DLE-LA-0004 | 49      | 2.0 | 16.0 | 22.0      | 42.3 | 31.00   | 150           |
| DLE-LA-0006 | 76      | 1.6 | 16.0 | 38.1      | 56.4 | 47.14   | 200           |

 dryspin® lead screws with precision machined ends ► Page 391

 Further technical data, downloads and ordering options at ► [www.igus.eu/motors](http://www.igus.eu/motors)



For DC, EC/BLDC and stepper motors



Travel distances, positions, speeds, operating times - easily defined in the new web-based control system from igus®.

A simple and intuitive browser-based user interface, extensive functionality with the option of "remote control" via Ethernet (Intranet) or bus system - "dryve" is the simple motor control method from igus® for your linear guide system.

**New:** The drylin® D2 is a drylin® D1 (without housing) for small installation spaces, such as in desktop devices

- Control via laptop, tablet or smartphone possible
- Suitable for all drylin® axes
- For DC, EC and stepper motors
- Communication by means of CANopen, Ethernet and digital inputs and outputs
- Compatible with many industrial control systems
- Cost-effective



#### Connections and displays

- 1 Voltage supply
- 2 Digital inputs
- 3 Digital outputs
- 4 Analogue inputs
- 5 Motor & brake connection
- 6 Angular encoder
- 7 CANopen
- 8 Ethernet
- 9 Advertisement

 Available from stock  
Detailed information about delivery time online.

 Technical data and further options  
► [www.igus.eu/dryve](http://www.igus.eu/dryve)

For DC motors





D3 dryve motor control unit makes it possible to easily control linear systems

The D3 dryve is a cost-effective control system for direct-current motors and is ready to use immediately. It can be connected quickly and is very easy to use – without any additional connection work. Buttons and rotary controls on the housing make it possible to control linear carriages without a PC, laptop or tablet. Different speeds as well as starting modes can be set.

- Easy to use, quick to connect
- Controls on the device make it possible to activate linear carriages, for example (anticlockwise/clockwise operation, speed, step mode or continuous operation)
- Different speeds and starting modes possible
- Can be combined with switches or joysticks
- Cost-effective, everything necessary and immediately ready for use for e.g. control on a camera slider

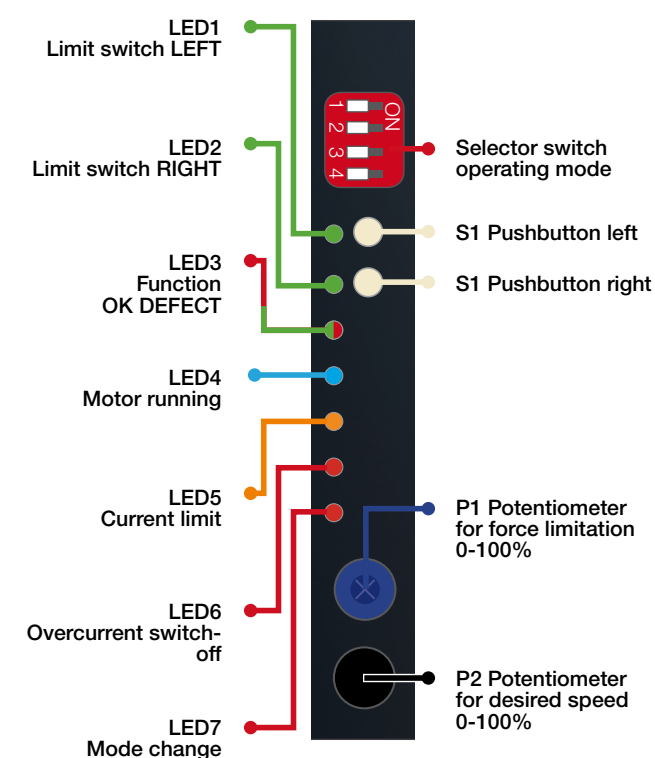
#### D3 dryve motor control system for all igus® DC motors



 Available from stock  
Detailed information about delivery time online.

 Technical data and further options  
► [www.igus.eu/dryve](http://www.igus.eu/dryve)

For stepper motors



Example image

dryve D7/8/9 motor control systems for all igus® stepper motors

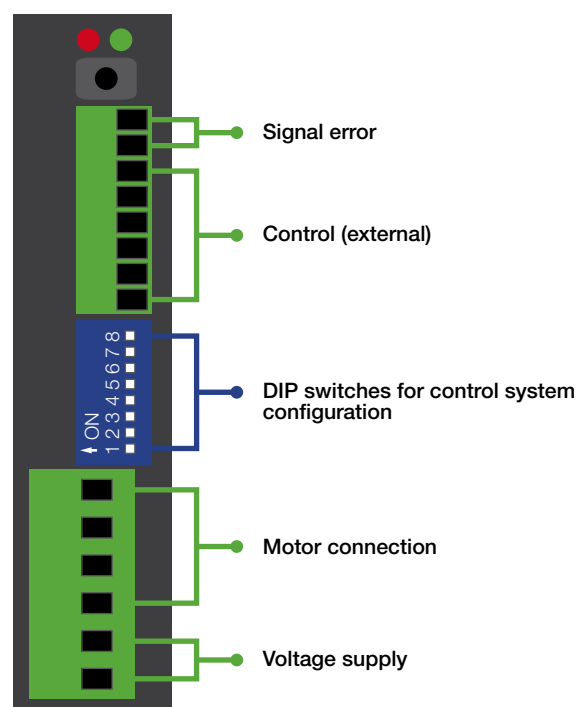

D7/8/9 dryve motor control units make it possible to easily control linear systems

The D7/8/9 control systems are low-cost, ready-to-use stepper motor controllers. They are quick and easy to connect. You can use the DIP switches to set the motor control system according to your needs.

- No software or app installation is necessary
- Quick initial operation
- Compatible with numerous industrial control systems (e.g. the Siemens S7 / Beckhoff)
- For stepper motors
- Cost-effective

Available from stock  
Detailed information about delivery time online.

Technical data and further options  
▶ [www.igus.eu/dryve](http://www.igus.eu/dryve)

Drives for DC motors



D5 dryve

D6 dryve

Terminal assignments

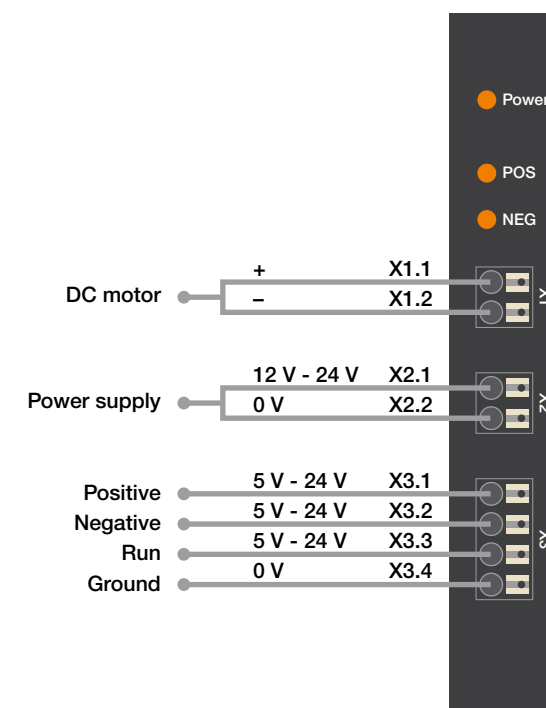

- Control DC motors
- Suitable for all igus® DC motors
- Motor speed can be controlled via PWM
- Easy installation of switch cabinet on TS35 rail

Technical data [mm]

| Part No.      | Type                          | Motor current<br>(duration/peak) |       | Nominal voltage | Protection class | Weight |
|---------------|-------------------------------|----------------------------------|-------|-----------------|------------------|--------|
|               |                               | [A]                              | [V]   |                 |                  |        |
| D5 <b>New</b> | Cased version                 | 10/30                            | 12-24 | IP20            | 130              |        |
| D6 <b>New</b> | Printed circuit board version | 10/30                            | 12-24 | IP00            | 20               |        |

Available from stock  
Detailed information about delivery time online.

Technical data and further options  
▶ [www.igus.eu/dryve](http://www.igus.eu/dryve)

## Planetary gear for stepper motors



- Planetary gearbox for EC/BLDC and stepper motors
- Increased torque
- Higher holding torque
- Various reduction ratios
- Compatible with motors with flange 42 / NEMA17

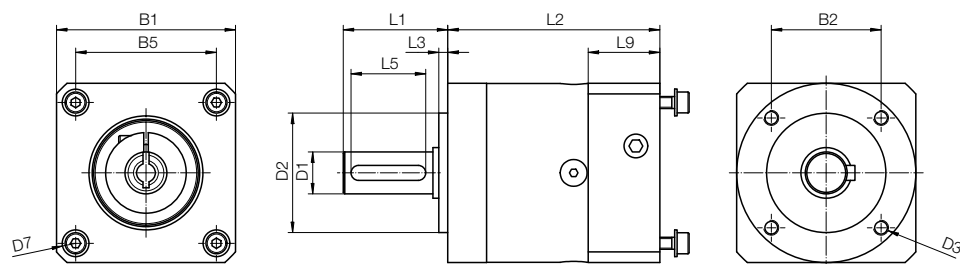

## Technical data and dimensions [mm]

| Part No.            | Gear reduction | Suitable for motor size | Motor diameter | Length | Nominal output torque | Drive shaft diameter | Weight |
|---------------------|----------------|-------------------------|----------------|--------|-----------------------|----------------------|--------|
|                     |                |                         |                |        | [Nm]                  |                      | [kg]   |
| GEA-40-3-40-ST-050  | New 3          | NEMA17                  | 5              | 66.5   | 11                    | 50                   | 0.35   |
| GEA-40-3-40-ST-080  | New 3          | NEMA17                  | 8              | 66.5   | 11                    | 80                   | 0.35   |
| GEA-40-5-40-ST-050  | New 5          | NEMA17                  | 5              | 66.5   | 14                    | 50                   | 0.35   |
| GEA-40-5-40-ST-080  | New 5          | NEMA17                  | 8              | 66.5   | 14                    | 80                   | 0.35   |
| GEA-40-10-40-ST-050 | New 10         | NEMA17                  | 5              | 66.5   | 5                     | 50                   | 0.35   |
| GEA-40-10-40-ST-080 | New 10         | NEMA17                  | 8              | 66.5   | 5                     | 80                   | 0.35   |
| GEA-40-15-40-ST-050 | New 15         | NEMA17                  | 5              | 79.5   | 18                    | 50                   | 0.45   |
| GEA-40-15-40-ST-080 | New 15         | NEMA17                  | 8              | 79.5   | 18                    | 80                   | 0.45   |
| GEA-40-20-40-ST-050 | New 20         | NEMA17                  | 5              | 79.5   | 20                    | 50                   | 0.45   |
| GEA-40-20-40-ST-080 | New 20         | NEMA17                  | 8              | 79.5   | 20                    | 80                   | 0.45   |
| GEA-40-40-40-ST-050 | New 40         | NEMA17                  | 5              | 79.5   | 18                    | 50                   | 0.45   |
| GEA-40-40-40-ST-080 | New 40         | NEMA17                  | 8              | 79.5   | 18                    | 80                   | 0.45   |

| Part No.            | B1     | B2 | D1 | D2 | L1 | L2   |
|---------------------|--------|----|----|----|----|------|
| GEA-40-3-40-ST-050  | New 40 | 24 | 12 | 26 | 26 | 67.5 |
| GEA-40-3-40-ST-080  | New 40 | 24 | 12 | 26 | 26 | 67.5 |
| GEA-40-5-40-ST-050  | New 40 | 24 | 12 | 26 | 26 | 67.5 |
| GEA-40-5-40-ST-080  | New 40 | 24 | 12 | 26 | 26 | 67.5 |
| GEA-40-10-40-ST-050 | New 40 | 24 | 12 | 26 | 26 | 67.5 |
| GEA-40-10-40-ST-080 | New 40 | 24 | 12 | 26 | 26 | 67.5 |
| GEA-40-15-40-ST-050 | New 40 | 24 | 12 | 26 | 26 | 80.5 |
| GEA-40-15-40-ST-080 | New 40 | 24 | 12 | 26 | 26 | 80.5 |
| GEA-40-20-40-ST-050 | New 40 | 24 | 12 | 26 | 26 | 80.5 |
| GEA-40-20-40-ST-080 | New 40 | 24 | 12 | 26 | 26 | 80.5 |
| GEA-40-40-40-ST-050 | New 40 | 24 | 12 | 26 | 26 | 80.5 |
| GEA-40-40-40-ST-080 | New 40 | 24 | 12 | 26 | 26 | 80.5 |



Available from stock

Detailed information about delivery time online.

## Planetary gear for stepper motors



- Planetary gearbox for EC/BLDC and stepper motors
- Increased torque
- Higher holding torque
- Various reduction ratios
- Compatible with motors with flange 56 / NEMA23 and with flange 60 / NEMA24

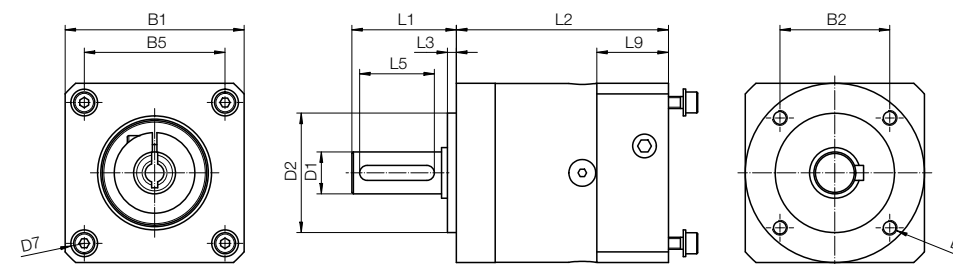

## Technical data and dimensions [mm]

| Part No.            | Gear reduction | Suitable for motor size | Nominal output torque | Drive shaft diameter | Weight |
|---------------------|----------------|-------------------------|-----------------------|----------------------|--------|
|                     |                |                         | [Nm]                  |                      | [kg]   |
| GEA-60-3-60-ST-063  | 3              | NEMA23                  | 28                    | 63                   | 0.88   |
| GEA-60-3-60-ST-080  | 3              | NEMA24/23               | 28                    | 80                   | 0.88   |
| GEA-60-5-60-ST-063  | 5              | NEMA23                  | 40                    | 63                   | 0.89   |
| GEA-60-5-60-ST-080  | 5              | NEMA24/23               | 40                    | 80                   | 0.89   |
| GEA-60-10-60-ST-063 | 10             | NEMA23                  | 15                    | 63                   | 0.90   |
| GEA-60-10-60-ST-080 | 10             | NEMA24/23               | 15                    | 80                   | 0.90   |
| GEA-60-15-60-ST-063 | 15             | NEMA23                  | 44                    | 63                   | 1.05   |
| GEA-60-15-60-ST-080 | 15             | NEMA24/23               | 44                    | 80                   | 1.05   |
| GEA-60-20-60-ST-063 | 20             | NEMA23                  | 44                    | 63                   | 1.10   |
| GEA-60-20-60-ST-080 | 20             | NEMA24/23               | 44                    | 80                   | 1.10   |
| GEA-60-40-60-ST-063 | 40             | NEMA23                  | 40                    | 63                   | 1.10   |
| GEA-60-40-60-ST-080 | 40             | NEMA24                  | 40                    | 80                   | 1.10   |

| Part No.            | B1 | B2   | D1 | D2 | L1 | L2 |
|---------------------|----|------|----|----|----|----|
| GEA-60-3-60-ST-063  | 60 | 36.7 | 14 | 40 | 35 | 71 |
| GEA-60-3-60-ST-080  | 60 | 36.7 | 14 | 40 | 35 | 71 |
| GEA-60-5-60-ST-063  | 60 | 36.7 | 14 | 40 | 35 | 71 |
| GEA-60-5-60-ST-080  | 60 | 36.7 | 14 | 40 | 35 | 71 |
| GEA-60-10-60-ST-063 | 60 | 36.7 | 14 | 40 | 35 | 71 |
| GEA-60-10-60-ST-080 | 60 | 36.7 | 14 | 40 | 35 | 71 |
| GEA-60-15-60-ST-063 | 60 | 36.7 | 14 | 40 | 35 | 84 |
| GEA-60-15-60-ST-080 | 60 | 36.7 | 14 | 40 | 35 | 84 |
| GEA-60-20-60-ST-063 | 60 | 36.7 | 14 | 40 | 35 | 84 |
| GEA-60-20-60-ST-080 | 60 | 36.7 | 14 | 40 | 35 | 84 |
| GEA-60-40-60-ST-063 | 60 | 36.7 | 14 | 40 | 35 | 84 |
| GEA-60-40-60-ST-080 | 60 | 36.7 | 14 | 40 | 35 | 84 |



Available from stock

Detailed information about delivery time online.



## Planetary gear for stepper motors



- Planetary gearbox for EC/BLDC and stepper motors
- Increased torque
- Higher holding torque
- Various reduction ratios
- Compatible with motors with flange 86 / NEMA34

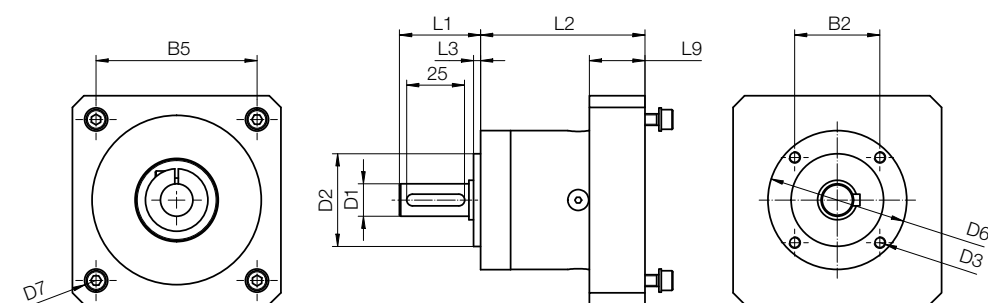

## Technical data and dimensions [mm]

| Part No.            | Gear reduction | Suitable for motor size | Nominal output torque [Nm] | Drive shaft diameter | Weight [kg] |
|---------------------|----------------|-------------------------|----------------------------|----------------------|-------------|
| GEA-60-3-90-ST-140  | 3              | NEMA34                  | 28                         | 140                  | 1.35        |
| GEA-60-5-90-ST-140  | 5              | NEMA34                  | 28                         | 140                  | 1.37        |
| GEA-60-10-90-ST-140 | 10             | NEMA34                  | 40                         | 140                  | 1.40        |
| GEA-60-15-90-ST-140 | 15             | NEMA34                  | 40                         | 140                  | 1.55        |
| GEA-60-20-90-ST-140 | 20             | NEMA34                  | 15                         | 140                  | 1.65        |
| GEA-60-40-90-ST-140 | 40             | NEMA34                  | 15                         | 140                  | 1.65        |

| Part No.            | B1 | B2   | D1 | D2 | L1 | L2 |
|---------------------|----|------|----|----|----|----|
| GEA-60-3-90-ST-140  | 60 | 36.7 | 14 | 40 | 35 | 86 |
| GEA-60-5-90-ST-140  | 60 | 36.7 | 14 | 40 | 35 | 86 |
| GEA-60-10-90-ST-140 | 60 | 36.7 | 14 | 40 | 35 | 86 |
| GEA-60-15-90-ST-140 | 60 | 36.7 | 14 | 40 | 35 | 99 |
| GEA-60-20-90-ST-140 | 60 | 36.7 | 14 | 40 | 35 | 99 |
| GEA-60-40-90-ST-140 | 60 | 36.7 | 14 | 40 | 35 | 99 |

## Coupling - vibration dampening and easy fitting

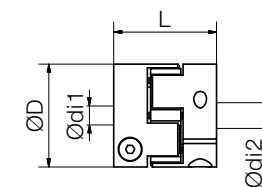

The coupling connects the drive pin of the axis to the motor. An elastic polymer insert in the centre of the coupling transfers the motor torque. This damping element compensates for radial and axial clearance.

- 20 versions from stock
- Vibration dampening and pluggable

Coupling material: Aluminium. TPU elastomeric centre. Shore hardness: 98 Sh A. Temperature range -30°C to +100°C.

| Toothed belt axis        | Motor type | Coupling                      | Techn. data - coupling |          |          |        |             |
|--------------------------|------------|-------------------------------|------------------------|----------|----------|--------|-------------|
|                          |            |                               | D                      | di1 [mm] | di2 [mm] | L [mm] | Weight [kg] |
| ZLW-0630-B               | NEMA17     | COU-AR-K-050-000-25-26-B-AAAB | 25.00                  | 5.00     | □6.00    | 26.00  | 0.02        |
|                          | NEMA23     | COU-AR-K-063-000-25-26-B-AAAB | 25.00                  | 6.35     | □6.00    | 26.00  | 0.02        |
|                          | DC motor31 | COU-AR-K-060-000-25-26-B-AAAB | 25.00                  | 6.00     | □6.00    | 26.00  | 0.02        |
| ZLW-0630-S               | NEMA17     | COU-AR-K-050-080-25-26-B-AAAA | 25.00                  | 5.00     | 8.00     | 26.00  | 0.02        |
|                          | NEMA23     | COU-AR-K-063-080-25-26-B-AAAA | 25.00                  | 6.35     | 8.00     | 26.00  | 0.02        |
|                          | DC motor31 | COU-AR-K-060-080-25-26-B-AAAA | 25.00                  | 6.00     | 8.00     | 26.00  | 0.02        |
| ZLW-1040-B / ZAW         | NEMA17     | COU-AR-K-050-000-25-26-B-AAAB | 25.00                  | 5.00     | □6.00    | 26.00  | 0.02        |
|                          | NEMA23     | COU-AR-K-063-000-25-26-B-AAAB | 25.00                  | 6.35     | □6.00    | 26.00  | 0.02        |
|                          | NEMA23XL   | COU-AR-K-080-000-25-26-B-AAAB | 25.00                  | 8.00     | □6.00    | 26.00  | 0.02        |
|                          | DC motor31 | COU-AR-K-060-000-25-26-B-AAAB | 25.00                  | 6.00     | □6.00    | 26.00  | 0.02        |
| ZLW-1040-S / ZAW         | NEMA23     | COU-AR-K-063-100-32-32-B-AAAA | 32.00                  | 6.35     | 10.00    | 32.00  | 0.05        |
|                          | NEMA23XL   | COU-AR-K-080-100-32-32-B-AAAA | 32.00                  | 8.00     | 10.00    | 32.00  | 0.05        |
|                          | NEMA34     | COU-AR-K-140-100-32-32-B-AAAA | 32.00                  | 14.00    | 10.00    | 32.00  | 0.05        |
|                          | DC motor31 | COU-AR-K-060-100-32-32-B-AAAA | 32.00                  | 6.00     | 10.00    | 32.00  | 0.05        |
| ZLW-1660-S               | NEMA34     | COU-AR-K-140-140-32-32-B-AAAA | 32.00                  | 14.00    | 14.00    | 32.00  | 0.05        |
| Lead screw axis          | Motor type | Coupling                      | Techn. data - coupling |          |          |        |             |
|                          |            |                               | D                      | di1 [mm] | di2 [mm] | L [mm] | Weight [kg] |
| SAW-0630 / SLW-BB-0630   | NEMA17     | COU-AR-K-050-080-25-26-B-AAAA | 25.00                  | 5.00     | 8.00     | 26.00  | 0.02        |
|                          | DC motor31 | COU-AR-K-060-080-25-26-B-AAAA | 25.00                  | 6.00     | 8.00     | 26.00  | 0.02        |
| SAW-1040 / SLW-(BB)-1040 | NEMA17     | COU-AR-K-050-100-32-32-B-AAAA | 32.00                  | 5.00     | 10.00    | 32.00  | 0.05        |
|                          | NEMA23     | COU-AR-K-063-100-32-32-B-AAAA | 32.00                  | 6.35     | 10.00    | 32.00  | 0.05        |
|                          | NEMA23XL   | COU-AR-K-080-100-32-32-B-AAAA | 32.00                  | 8.00     | 10.00    | 32.00  | 0.05        |
|                          | DC motor31 | COU-AR-K-060-100-32-32-B-AAAA | 32.00                  | 6.00     | 10.00    | 32.00  | 0.05        |
| SLW-(BB)-1660            | NEMA23     | COU-AR-K-063-140-32-32-B-AAAA | 32.00                  | 6.35     | 14.00    | 32.00  | 0.05        |
|                          | NEMA23XL   | COU-AR-K-080-140-32-32-B-AAAA | 32.00                  | 8.00     | 14.00    | 32.00  | 0.05        |
| SLW-(BB)-2080            | NEMA23     | COU-AR-K-063-120-32-32-B-AAAA | 32.00                  | 6.35     | 12.00    | 32.00  | 0.05        |
|                          | NEMA23XL   | COU-AR-K-080-120-32-32-B-AAAA | 32.00                  | 8.00     | 12.00    | 32.00  | 0.05        |
|                          | NEMA34     | COU-AR-K-140-120-32-32-B-AAAA | 32.00                  | 14.00    | 12.00    | 32.00  | 0.05        |
| SHT-(BB)-12              | NEMA17     | COU-AR-K-050-100-32-32-B-AAAA | 32.00                  | 5.00     | 10.00    | 32.00  | 0.05        |
|                          | NEMA23     | COU-AR-K-063-100-32-32-B-AAAA | 32.00                  | 6.35     | 10.00    | 32.00  | 0.05        |
|                          | NEMA23XL   | COU-AR-K-080-100-32-32-B-AAAA | 32.00                  | 8.00     | 10.00    | 32.00  | 0.05        |
|                          | DC motor31 | COU-AR-K-060-100-32-32-B-AAAA | 32.00                  | 6.00     | 10.00    | 32.00  | 0.05        |
| SHT-(BB)-20              | NEMA23     | COU-AR-K-063-120-32-32-B-AAAA | 32.00                  | 6.35     | 12.00    | 32.00  | 0.05        |
|                          | NEMA23XL   | COU-AR-K-080-120-32-32-B-AAAA | 32.00                  | 8.00     | 12.00    | 32.00  | 0.05        |
|                          | NEMA34     | COU-AR-K-140-120-32-32-B-AAAA | 32.00                  | 14.00    | 12.00    | 32.00  | 0.05        |
| SHT-(BB)-30              | NEMA34     | COU-AR-K-140-140-32-32-B-AAAA | 32.00                  | 14.00    | 14.00    | 32.00  | 0.05        |



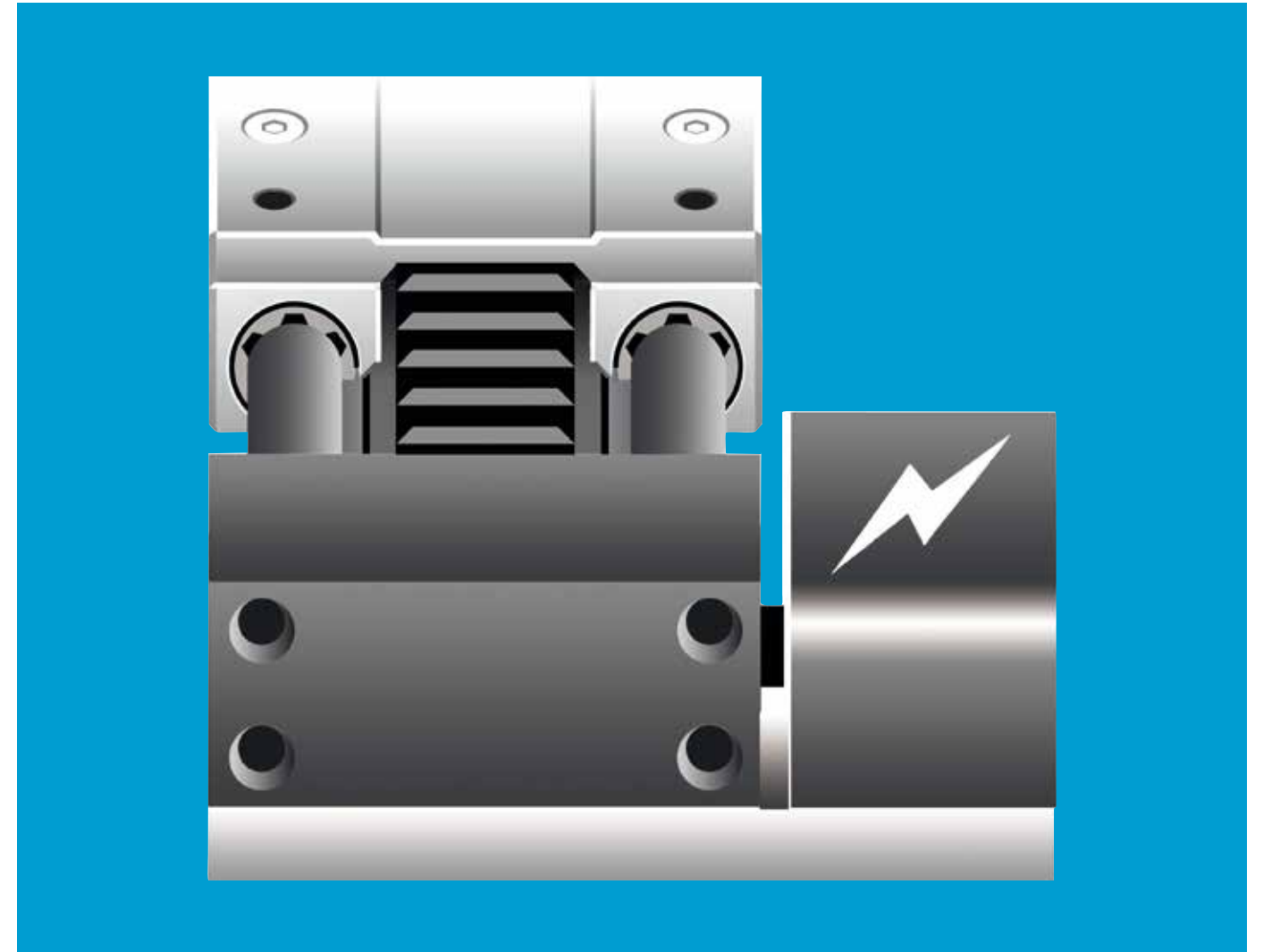
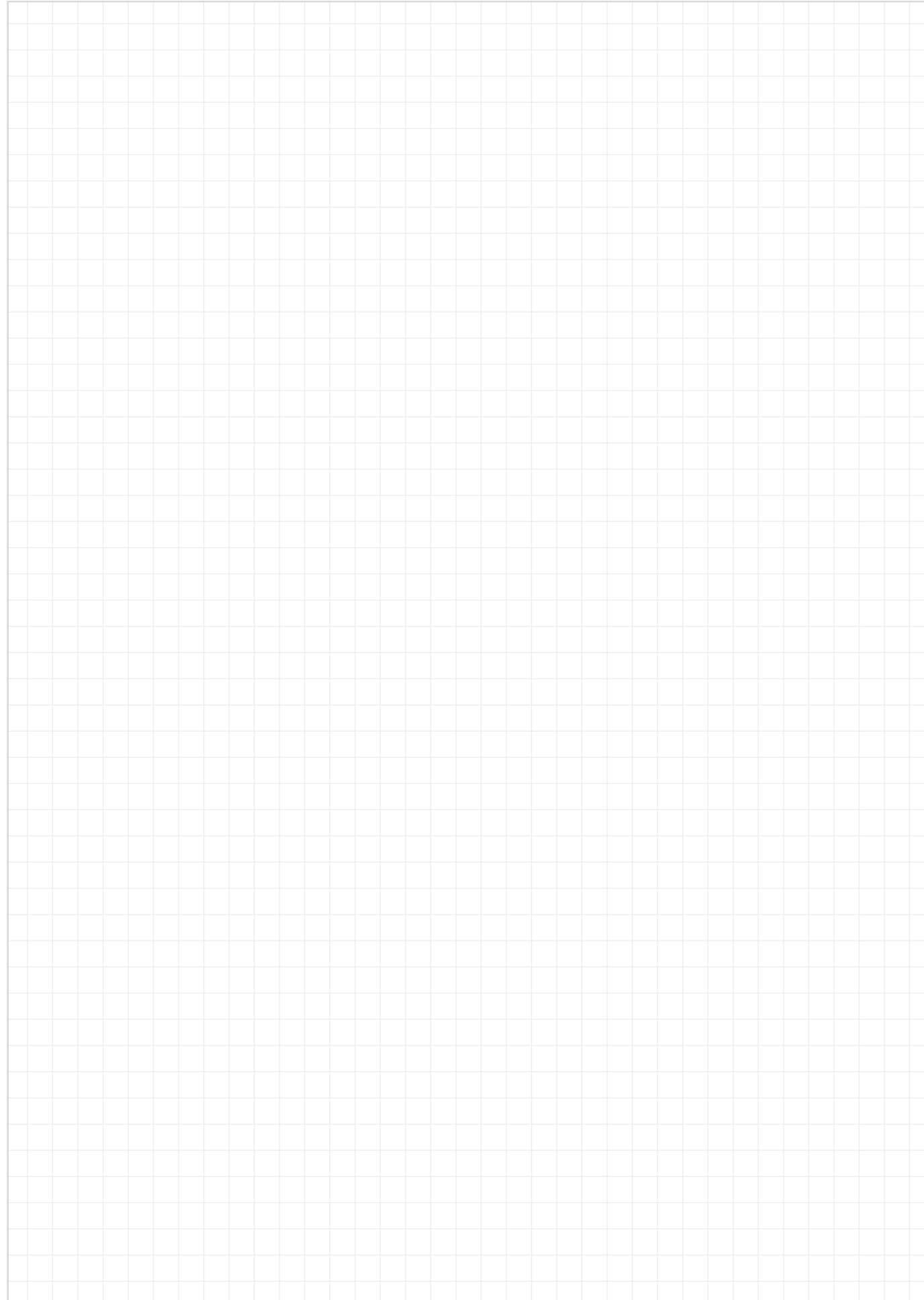

## drylin® E - accessories

Cables and proximity switches

Brake resistors

Motor flange

Mounting accessories

Fasteners



## Accessories for drylin® linear axes

Almost every drylin® linear axis can be retrofitted with a corresponding motor and accessories such as initiators (proximity switches). igus® offers a large modular system of motors, matching couplings and motor flanges plus many practical components for the combination of linear axes as well as fastening material.

- Connection of stepper motors and DC motors
- Linear robot structures
- Numerous fastening options

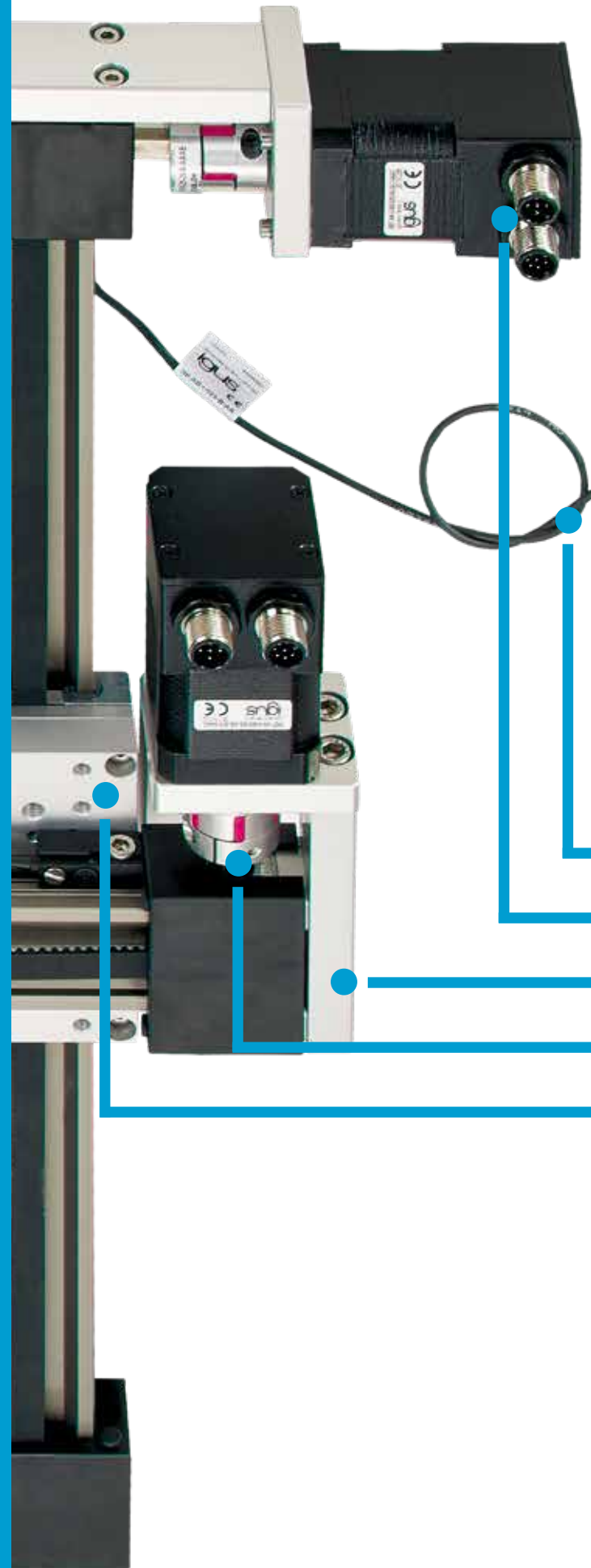

chainflex® motor and encoder cables

drylin® stepper and DC motors

Motor flange made of aluminium

Couplings for motor and shaft connection

Adapter plates for linear robot structures



**Available from stock**

Detailed information about delivery time online.

EN 09/2023

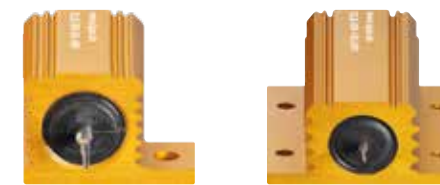

### Cables and proximity switches

- chainflex® connection cables with straight or angled connectors
  - Proximity switches: limit and reference switches
  - For drylin® linear modules and toothed belt axes
- Page 674

### Motor flange

- Motor connection for drylin® linear axes
  - For stepper and DC motors
  - Suitable for igus® couplings
- Page 680

### Mounting accessories

- Adapter plates for linear robot structures
  - Spacer for height adjustment of SHT/SLW linear modules
  - Mounting material
- Page 681

EN 09/2023



## Connecting cables for NEMA stepper motors with metric connectors



The ideal complement to the drylin® product range provides chainflex® connection cables.

- Suitable for energy chains
- Shielded and oil-resistant
- Straight and angled connectors

## Flange size 28 (NEMA11), 42 (NEMA17), 56 (NEMA23), 60 (NEMA24)

| Part No.                   | Jacket | Cable type    | Cable length [m] | Connector |
|----------------------------|--------|---------------|------------------|-----------|
| <b>Motor cable M12</b>     |        |               |                  |           |
| DLE904121451-3             | TPE    | CF9.03.05.INI | 3.0              | straight  |
| DLE904121451-5             | TPE    | CF9.03.05.INI | 5.0              | straight  |
| DLE904121451-10            | TPE    | CF9.03.05.INI | 10.0             | straight  |
| DLE904121452-3             | TPE    | CF9.03.05.INI | 3.0              | angled    |
| DLE904121452-5             | TPE    | CF9.03.05.INI | 5.0              | angled    |
| DLE904121452-10            | TPE    | CF9.03.05.INI | 10.0             | angled    |
| <b>Motor cable JST</b>     |        |               |                  |           |
| DLE904121461-3 <b>New</b>  | TPE    | CF9.03.05.INI | 3.0              | straight  |
| DLE904121461-5 <b>New</b>  | TPE    | CF9.03.05.INI | 5.0              | straight  |
| DLE904121461-10 <b>New</b> | TPE    | CF9.03.05.INI | 10.0             | straight  |
| <b>Encoder M12</b>         |        |               |                  |           |
| DLE904121455-3             | PVC    | CF240.02.08   | 3.0              | straight  |
| DLE904121455-5             | PVC    | CF240.02.08   | 5.0              | straight  |
| DLE904121455-10            | PVC    | CF240.02.08   | 10.0             | straight  |
| DLE904121456-3             | PVC    | CF240.02.08   | 3.0              | angled    |
| DLE904121456-5             | PVC    | CF240.02.08   | 5.0              | angled    |
| DLE904121456-10            | PVC    | CF240.02.08   | 10.0             | angled    |
| <b>Encoder JST NEMA11</b>  |        |               |                  |           |
| DLE904121459-3 <b>New</b>  | TPE    | CF11.01.04.02 | 3.0              | straight  |
| DLE904121459-5 <b>New</b>  | TPE    | CF11.01.04.02 | 5.0              | straight  |
| DLE904121459-10 <b>New</b> | TPE    | CF11.01.04.02 | 10.0             | straight  |

## Flange size 86 (NEMA34)

| Part No.                              | Jacket | Cable type    | Cable length [m] | Connector |
|---------------------------------------|--------|---------------|------------------|-----------|
| <b>Motor cable with brake M17</b>     |        |               |                  |           |
| DLE904121457-3                        | PUR    | CF78.UL.07.07 | 3.0              | straight  |
| DLE904121457-5                        | PUR    | CF78.UL.07.07 | 5.0              | straight  |
| DLE904121457-10                       | PUR    | CF78.UL.07.07 | 10.0             | straight  |
| <b>Molex motor cable</b>              |        |               |                  |           |
| DLE904161278-3 <b>New</b>             | TPE    | CF880.07.05   | 3.0              | straight  |
| DLE904161278-5 <b>New</b>             | TPE    | CF880.07.05   | 5.0              | straight  |
| DLE904161278-10 <b>New</b>            | TPE    | CF880.07.05   | 10.0             | straight  |
| <b>Encoder M17</b>                    |        |               |                  |           |
| DLE904121458-3                        | PVC    | CF211.009     | 3.0              | straight  |
| DLE904121458-5                        | PVC    | CF211.009     | 5.0              | straight  |
| DLE904121458-10                       | PVC    | CF211.009     | 10.0             | straight  |
| <b>Encoder for NEMA17, 23, 24, 34</b> |        |               |                  |           |
| DLE904121460-3 <b>New</b>             | TPE    | CF11.01.04.02 | 3.0              | straight  |
| DLE904121460-5 <b>New</b>             | TPE    | CF11.01.04.02 | 5.0              | straight  |
| DLE904121460-10 <b>New</b>            | TPE    | CF11.01.04.02 | 10.0             | straight  |

## Flange size 42 (NEMA17), 56 (NEMA23), 60 (NEMA24)

| Part No.                                | Jacket | Cable type    | Cable length [m] | Connector |
|---|--------|---------------|------------------|-----------|
| <b>Brake cable with M8 sensor cable</b> |        |               |                  |           |
| DLE904121453-3                          | TPE    | CF9.02.03.INI | 3.0              | straight  |
| DLE904121453-5                          | TPE    | CF9.02.03.INI | 5.0              | straight  |
| DLE904121453-10                         | TPE    | CF9.02.03.INI | 10.0             | straight  |
| DLE904121454-3                          | TPE    | CF9.02.03.INI | 3.0              | angled    |
| DLE904121454-5                          | TPE    | CF9.02.03.INI | 5.0              | angled    |
| DLE904121454-10                         | TPE    | CF9.02.03.INI | 10.0             | angled    |

## DC motors

| Part No.                               | Jacket | Cable type     | Cable length [m] | Connector |
|--|--------|----------------|------------------|-----------|
| <b>Motor cable with flat connector</b> |        |                |                  |           |
| DLE904137923-3 <b>New</b>              | PVC    | CF130.05.02.UL | 3.0              | flat      |
| DLE904137923-5 <b>New</b>              | PVC    | CF130.05.02.UL | 5.0              | flat      |
| DLE904137923-10 <b>New</b>             | PVC    | CF130.05.02.UL | 10.0             | flat      |
| DLE904137924-3 <b>New</b>              | PVC    | CF130.05.02.UL | 3.0              | flat      |
| DLE904137924-5 <b>New</b>              | PVC    | CF130.05.02.UL | 5.0              | flat      |
| DLE904137924-10 <b>New</b>             | PVC    | CF130.05.02.UL | 10.0             | flat      |

## DC motors with spline

| Part No.                               | Jacket | Cable type     | Cable length [m] | Connector |
|--|--------|----------------|------------------|-----------|
| <b>Motor and angular encoder cable</b> |        |                |                  |           |
| DLE904121462-3 <b>New</b>              | PVC    | CF211.033      | 3.0              | straight  |
| DLE904121462-5 <b>New</b>              | PVC    | CF211.033      | 5.0              | straight  |
| DLE904121462-10 <b>New</b>             | PVC    | CF211.033      | 10.0             | straight  |
| DLE904121463-3 <b>New</b>              | PVC    | CF130.05.07.UL | 3.0              | straight  |
| DLE904121463-5 <b>New</b>              | PVC    | CF130.05.07.UL | 5.0              | straight  |
| DLE904121463-10 <b>New</b>             | PVC    | CF130.05.07.UL | 10.0             | straight  |

## Proximity switches - limit and reference switches



## Technical data

| Sensor/actuator      | Unit  |           |
|----------------------|-------|-----------|
| Operating voltage    | [VDC] | 10...30   |
| Max. trigger current | [mA]  | 100       |
| Ambient temperature  | [°C]  | -25...+70 |
| Trigger distance     | [SN]  | 2.5       |
| Protection class     |       | IP67      |
| Connector            |       | M8        |

20-30mm of extra stroke length is required for each limit reference switch.

| axis        | Part No.             |         |
|-------------|----------------------|---------|
|             | Proximity switch kit |         |
|             | Opener               | Closer  |
| SAW-0630    | IK-0001              | IK-0002 |
| SAW-1040    | IK-0001              | IK-0002 |
| SAW-1660    | IK-0003              | IK-0004 |
| SLW-BB-0630 | -                    | -       |
| SLW-BB-1040 | IK-0006              | IK-0017 |
| SLW-BB-1080 | IK-0007              | IK-0018 |
| SLW-BB-1660 | IK-0008              | IK-0019 |
| SLW-BB-2080 | IK-0009              | IK-0020 |
| SHT-BB-12   | IK-0011              | IK-0022 |
| SHT-BB-20   | IK-0012              | IK-0023 |
| SHT-BB-30   | -                    | -       |
| SLW-1040-AL | IK-0006              | IK-0017 |
| SLW-1080    | IK-0007              | IK-0018 |
| SLW-1660    | IK-0008              | IK-0019 |
| SLW-2080    | IK-0009              | IK-0020 |
| SHT-12      | IK-0011              | IK-0022 |
| SHT-20      | IK-0012              | IK-0023 |
| SHT-30      | -                    | -       |
| ZLW-0630-B  | IK-0001              | IK-0002 |
| ZLW-0630-S  | IK-0001              | IK-0002 |
| ZLW-1040-B  | IK-0001              | IK-0002 |
| ZLW-1040-S  | IK-0001              | IK-0002 |
| ZAW-1040-B  | IK-0001              | IK-0002 |
| ZAW-1040-S  | IK-0001              | IK-0002 |
| ZLW-1660-S  | IK-0003              | IK-0004 |

The compact and easy assembly of the proximity switches represent a logical extension of the kit approach for the drylin® range. The plastic housing makes the proximity switches, which can be used as limit, position or reference switches, particularly light and tough.

## Pin assignment

| Proximity switch | M8 3-pin | Proximity switch cable |        |
|------------------|----------|------------------------|--------|
| PIN              | Signal   | PIN                    | Colour |
| 1                | +        | 1                      | brown  |
| 3                | -        | 3                      | blue   |
| 4                | load     | 4                      | black  |



Matching cables are added by including the following attachments:



A proximity switch kit for SAW & ZLW includes a proximity switch, a bracket and mounting screws



A proximity switch kit for SLW & SHT includes a proximity switch, two spacers and mounting screws.

## Proximity switches - kit with support



**Part No.**  
IK-0201-2  
Proximity PNP NC kit with straight support

**Part No.**  
IK-0200-2  
Proximity PNP NC kit with angled support

Reposition and adjustment is possible using a bracket with the proximity switch

- Cable length: 2m
- Material holder: steel

## ZSY-INI-AS-B

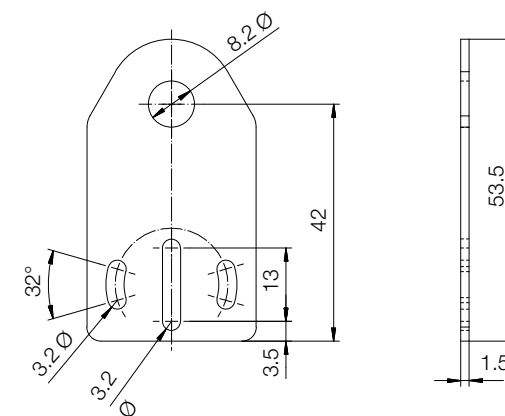

## ZSY-INI-AS-A

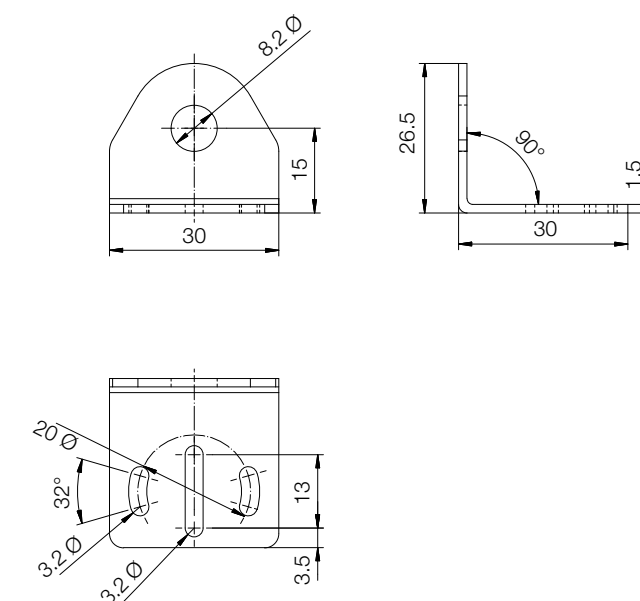

## INI-AS-I-015-B-AA

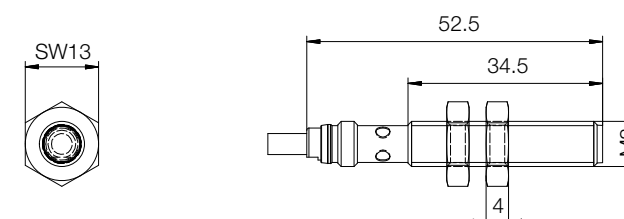



Brake resistors

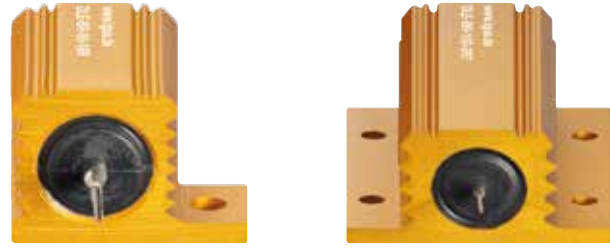

Example image

- Braking resistors for safety at high speeds
- Compact
- Easy to connect

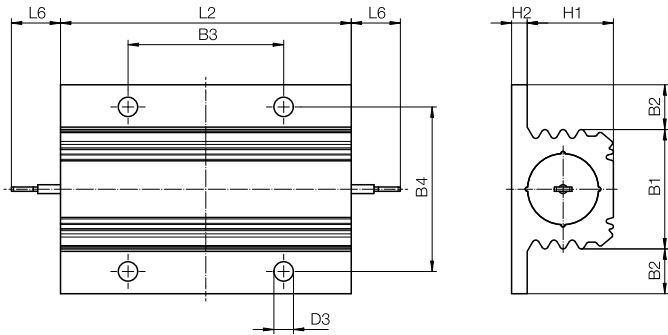

Technical data

| Part No.       | Installation size | Performance class | Resistance value | Weight |
|----------------|-------------------|-------------------|------------------|--------|
|                |                   | [W]               | [Ω]              | [kg]   |
| DLE-BR-50-18R  | NEMA17            | 50                | 18.0             | 0.030  |
| DLE-BR-75-4R7  | NEMA23            | 75                | 4.7              | 0.085  |
| DLE-BR-100-3R3 | NEMA24            | 100               | 3.3              | 0.115  |
| DLE-BR-100-2R7 | NEMA34            | 100               | 2.7              | 0.115  |

Dimensions [mm]

| Part No.       | L    | A<br>max. | H  | C<br>max. | L2   | L6   | B1<br>max. | B2<br>max. | H1   | H2 |
|----------------|------|-----------|----|-----------|------|------|------------|------------|------|----|
|                |      |           |    |           |      |      |            |            |      |    |
| DLE-BR-50-18R  | 50.1 | 72.5      | 30 | 17        | 50.1 | 11.2 | 12.8       | 8.6        | 14.0 | 3  |
| DLE-BR-75-4R7  | 48.9 | 71.0      | 48 | 26        | 48.9 | 11.1 | 26.0       | 11.0       | 22.0 | 4  |
| DLE-BR-100-3R3 | 65.4 | 87.5      | 48 | 26        | 65.4 | 11.1 | 26.0       | 11.0       | 4.0  | 4  |
| DLE-BR-100-2R7 | 65.4 | 87.5      | 48 | 26        | 65.4 | 11.1 | 26.0       | 11.0       | 4.0  | 4  |

Linear robot drives

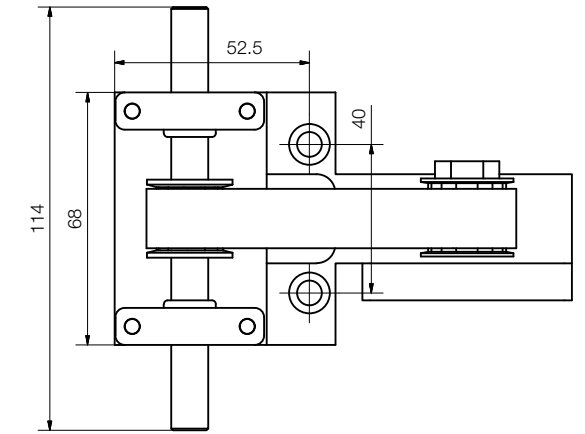
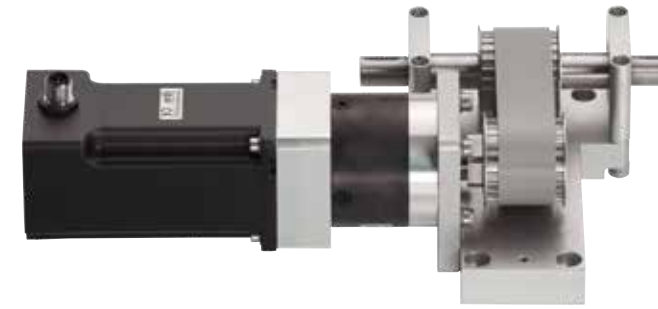

- Connection of NEMA stepper motors in linear robot structures
- Space-saving
- More safety due to encoder and brake

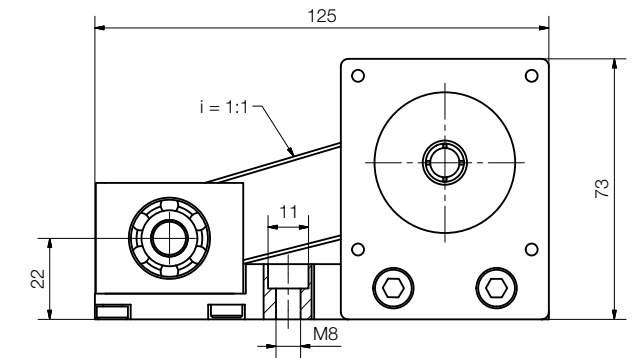

Dimensions [mm]

| Part No. | Installation size | Motor    | Design            |
|----------|-------------------|----------|-------------------|
| GD-0001  | 1                 | NEMA23   | Stranded wire     |
| GD-0002  | 1                 | NEMA23   | Connector         |
| GD-0003  | 1                 | NEMA23   | Encoder           |
| GD-0004  | 1                 | NEMA23   | Encoder and brake |
| GD-0005  | 1                 | NEMA23XL | Stranded wire     |
| GD-0006  | 1                 | NEMA23XL | Connector         |
| GD-0007  | 1                 | NEMA23XL | Encoder           |
| GD-0008  | 1                 | NEMA23XL | Encoder and brake |

Using motor flange for stepper and DC motors

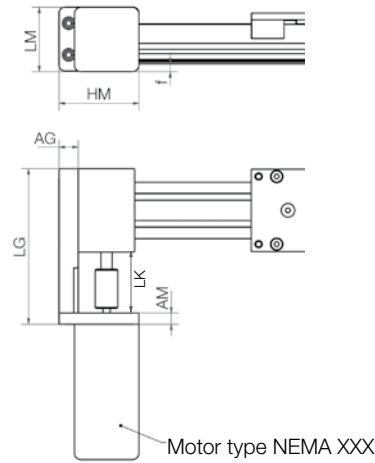

- 2 base plate lengths for each NEMA motor flange; others upon request
- Suitable for drylin® coupling ► Page 669

Dimensions [mm]

| Part No.         | Matching linear modules | Base plate |      |      |    | Motor flange |      |      |
|------------------|-------------------------|------------|------|------|----|--------------|------|------|
|                  |                         | AG         | LG   | LK   | AM | HM           | LM   | f    |
| MF-0630-NEMA17-S | ZLW-0630                | 12         | 99.5 | 35.5 | 10 | 53           | 42   | 7    |
| MF-0630-NEMA23-S | ZLW-0630                | 12         | 99.5 | 35.5 | 10 | 59           | 56   | 14   |
| MF-1040-NEMA17-S | ZLW-1040                | 17         | 119  | 35   | 10 | 63           | 44   | -    |
| MF-1040-NEMA23-S | ZLW-1040                | 17         | 119  | 35   | 10 | 70.7         | 56.4 | 7    |
| MF-1040-NEMA34-L | ZLW-1040                | 17         | 138  | 54   | 10 | 85           | 85   | 20.5 |
| MF-1660-NEMA34-S | ZLW-1660                | 15         | 166  | 52   | 10 | 86           | 86   | -    |
| MF-2260-NEMA23-S | ZAW-1040                | 10         | 108  | 35   | 10 | 70.7         | 56.4 | -    |
| MF-0630-DC0310   | ZLW-0630                | 12         | 99.5 | 35.5 | 10 | 53           | 42   | 7    |
| MF-1040-DC0310   | ZLW-1040                | 17         | 119  | 35   | 10 | 63           | 44   | -    |
| MF-1040-DC0350   | ZLW-1040                | 17         | 119  | 35   | 10 | 63           | 44   | -    |



The motor flange, sometimes called motor enclosure, encloses and protects the coupling and provides the matching mounting dimensions for your NEMA motor.

- Suitable for drylin® coupling ► Page 669

Dimensions [mm]

| Part No.          | Matching linear modules         | LG | AM | HM | LM | b  | f  | ha   |
|-------------------|---------------------------------|----|----|----|----|----|----|------|
| MF-1123-NEMA17    | SAW/SLW-BB-0630                 | 45 | -  | 43 | 43 | 43 | -  | 21.5 |
| MF-2040-NEMA17    | SAW/SLW-1040-AL, SHT-12         | 47 | 12 | 56 | 56 | 56 | -  | 21.5 |
| MF-2040-NEMA23-S  | SAW/SLW-1040-AL, SHT-12/20      | 48 | 13 | 56 | 56 | 56 | -  | 28   |
| MF-3648-NEMA23    | SHT-20, SHT-BB-20               | 56 | 13 | 56 | 56 | 56 | -  | 28   |
| MF-3648-NEMA34    | SLW-1660/2080, SLW-BB-1660/2080 | 65 | 10 | 86 | 86 | 46 | 20 | 43   |
| MF-3648-NEMA34-XL | SHT-30, SHT-BB-30               | 76 | 10 | 86 | 86 | 56 | 15 | 43   |
| MF-1123-DC0310    | SAW/SLW-BB-0630                 | 45 | -  | 43 | 43 | 43 | -  | 21.5 |
| MF-2040-DC0310    | SAW/SLW-1040-AL, SHT12          | 47 | 12 | 43 | 43 | 43 | -  | 21.5 |
| MF-2040-DC0350    | SAW/SLW-1040-AL, SHT12          | 47 | 12 | 43 | 43 | 43 | -  | 21.5 |

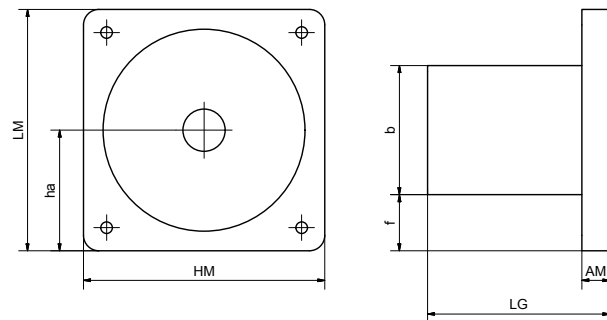

EN 09/2023



Spacer - height compensation for SLW/SHT linear modules



The spacer is an aluminium standoff that brings the selected drylin® linear unit to a height that matches your NEMA stepper motor. An attachment feature for proximity switches is already integrated. Retro-fitting is also possible.

- Adapter kit contains two spacers for connection of a linear module

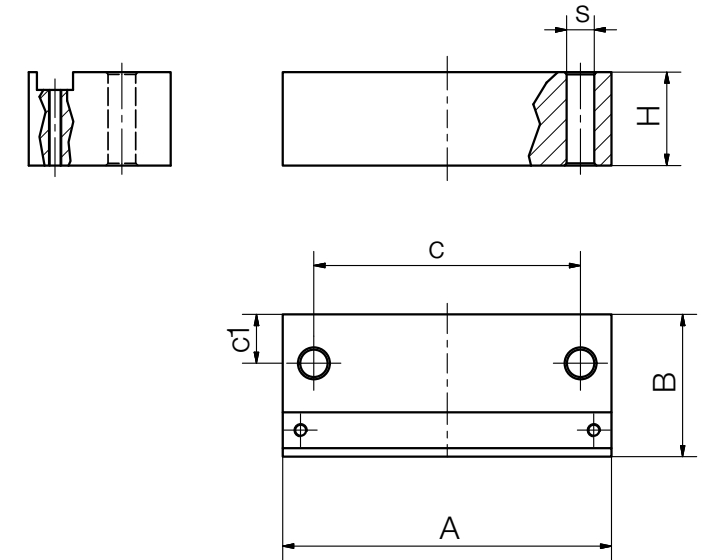

| Part No. | Suitable for linear module |
|----------|----------------------------|
| AK-0001  | SLW-1040                   |
| AK-0002  | SLW-1080                   |
| AK-0003  | SLW-1660                   |
| AK-0004  | SLW-2080                   |
| AK-0027  | SHT-08                     |
| AK-0006  | SHT-12                     |
| AK-0007  | SHT-20                     |
| AK-0008  | SHT-30                     |
| AK-0009  | SLW-25120                  |

Dimensions [mm]

| Part No. | A        | B    | H    | c<br>±0.1 | c1   | Ø s<br>+0.2 |
|----------|----------|------|------|-----------|------|-------------|
| AK-0001  | 74       | 32.0 | 21.0 | 60        | 11.0 | 6.2         |
| AK-0002  | 108      | 32.0 | 21.0 | 94        | 11.0 | 6.2         |
| AK-0003  | 104 -0.2 | 35.0 | 24.5 | 84        | 12.5 | 8.1         |
| AK-0004  | 134      | 38.0 | 20.0 | 116       | 14.0 | 9.0         |
| AK-0027  | 65       | 25.5 | 13.0 | 52        | 7.75 | 5.5         |
| AK-0006  | 85       | 40.0 | 17.5 | 70        | 15.0 | 6.2         |
| AK-0007  | 130      | 46.0 | 22.0 | 108       | 18.0 | 10.5        |
| AK-0008  | 180      | 60.0 | 10.0 | 150 ±0.2  | 25.0 | 13.5        |
| AK-0009  | 200      | 45.0 | 16.0 | 173 ±0.2  | 17.5 | 13.5        |

EN 09/2023



## Mounting bracket for SAW linear modules and ZLW toothed belt axes



For the assembly of drylin® ZLW toothed belt axes

- Available for drylin® WSX/SAW(C)/ZLW  
Sizes 0630/1040/1080/1660
- Material: anodised aluminium
- Connection options: T-slots profile, linear axis/  
proximity switches
- Multiple positions
- Quick mounting without drilling
- Including swivel-in slot nuts and screws for fastening

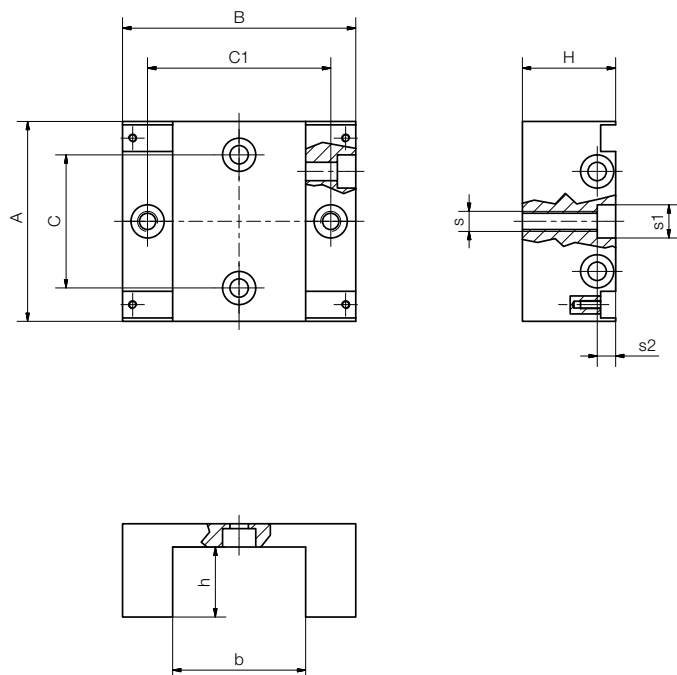

| Part No. | Suitable for |               |                   |
|----------|--------------|---------------|-------------------|
|          | Rail profile | Linear module | Toothed belt axis |
| AK-0037  | WSX-06-30    | SAW(C)-0630   | ZLW-0630          |
| AK-0038  | WSX-10-40    | SAW(C)-1040   | ZLW-1040          |
| AK-0039  | WSX-10-80    | SAW-1080      | ZLW-1080          |
| AK-0040  | WSX-16-60    | SAW-1660      | ZLW-1660          |

## Dimensions [mm]

| Part No. | A  | B   | H  | h  | b  | C  | C1 | Øs | s1  | s2  |
|----------|----|-----|----|----|----|----|----|----|-----|-----|
| AK-0037  | 60 | 70  | 20 | 12 | 30 | 40 | 50 | M6 | Ø10 | 5.5 |
| AK-0038  | 60 | 70  | 28 | 21 | 40 | 40 | 55 | M6 | Ø10 | 5.5 |
| AK-0039  | 60 | 104 | 28 | 21 | 74 | 40 | 90 | M6 | Ø10 | 5.5 |
| AK-0040  | 60 | 98  | 47 | 37 | 62 | 40 | 80 | M8 | Ø11 | 27  |

## Adapter kit for linear robot setup



- Simple and fast multi-axes linear robot setup
- For lead screw and toothed belt axes
- Energy chain assembly preparation
- Anodised aluminium
- Space and weight-saving
- Mounting of y-axis on 2 x-axes

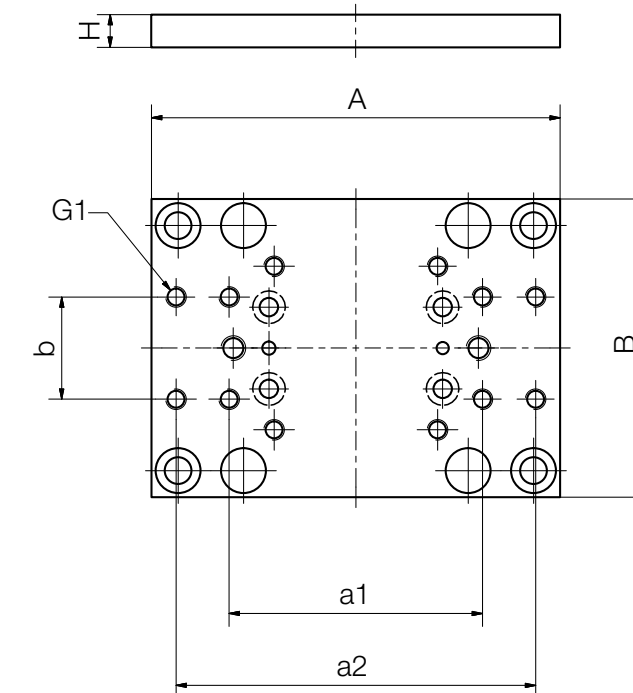

## Mounting of y-axis on two x-axes

| Part No. | x-axis                   | y-axis                       | Function linear robot setup |
|----------|--------------------------|------------------------------|-----------------------------|
| AK-0011  | ZLW-0630, 100mm carriage | ZLW-0630, ZLW-1040           | Assembly y-axis             |
| AK-0012  | ZLW-1040, 100mm carriage | ZLW-0630, ZLW-1040           | Assembly y-axis             |
| AK-0013  | ZLW-1040, 150mm carriage | ZLW-0630, ZLW-1040, ZLW-1080 | Assembly y-axis             |
| AK-0014  | ZLW-1660, 250mm carriage | ZLW-1040, ZLW-1080           | Assembly y-axis             |
| AK-0024  | ZLW-1040, 200mm carriage | ZLW-0630, ZLW-1040, ZLW-1080 | Assembly y-axis             |
| AK-0025  | ZLW-1080, 150mm carriage | ZLW-0630, ZLW-1040, GRW-0630 | Assembly y-axis             |

## Dimensions [mm]

| Part No. | A    | B    | G1 | H  | a1  | a2   | b  |
|----------|------|------|----|----|-----|------|----|
|          | -0.3 | -0.3 |    |    |     | +0.2 |    |
| AK-0011  | 100  | 54   | M5 | 13 | 62  | 88   | 25 |
| AK-0012  | 100  | 73   | M5 | 8  | 62  | 88   | 25 |
| AK-0013  | 150  | 73   | M5 | 8  | 112 | 138  | 25 |
| AK-0014  | 250  | 104  | M5 | 10 | -   | 232  | 35 |
| AK-0024  | 200  | 73   | M5 | 8  | 162 | 188  | 25 |
| AK-0025  | 150  | 107  | M5 | 8  | 112 | 138  | 25 |

## T-slot plates

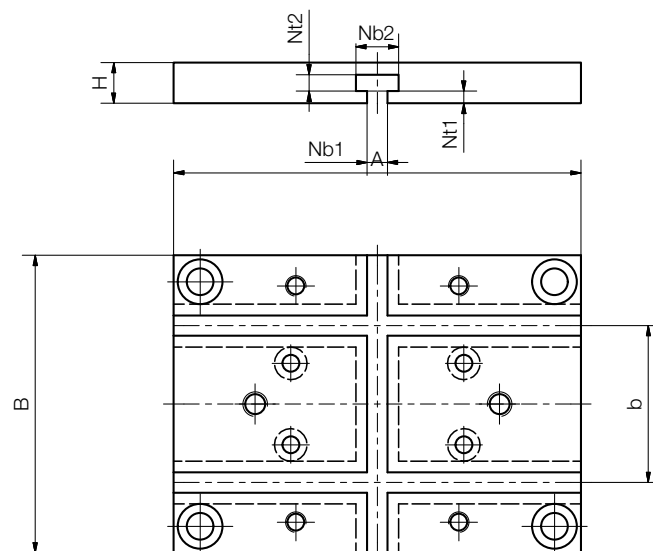

- Anodised aluminium
- Various fixing options
- Can be retrofitted
- For XY linear robot structures
- Suitable igus® slot nuts available ► Page 685

## Variable T-slot mounting plates

| Part No. | Base axis                | Axis to be mounted                       |
|----------|--------------------------|--|
| AK-0021  | SAW-1080, 100mm carriage | ZLW/SAW-0630, ZLW/SAW-1040, GRW-0630     |
| AK-0022  | SAW-1040, 100mm carriage | ZLW/SAW-0630, ZLW/SAW-1040, GRW-0630     |
| AK-0023  | SAW-1660, 150mm carriage | ZLW/SAW-1040, ZLW/SAW-1080, ZLW/SAW-1660 |

## Dimensions [mm]

| Part No. | A    | B    | H  | b    | Nb1  | Nb2  | Nt1 | Nt2  |
|----------|------|------|----|------|------|------|-----|------|
|          | -0.3 | -0.3 |    |      | +0.2 |      |     | +0.2 |
| AK-0021  | 100  | 107  | 10 | 42.5 | 5    | 10.5 | 3   | 4    |
| AK-0022  | 100  | 73   | 10 | 38.5 | 5    | 10.5 | 3   | 4    |
| AK-0023  | 150  | 104  | 10 | 42.5 | 5    | 10.5 | 3   | 4    |

## Slot nuts for mounting

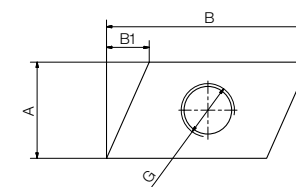

NOR-20602

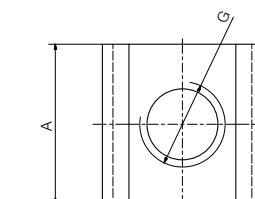

NOR-20605

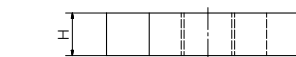

NOR-20613

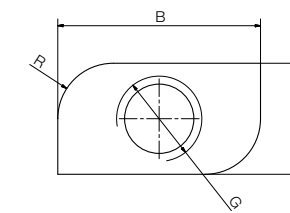

For the drylin® W high-profile rail, slot nuts offer variable ways of fastening sensors and proximity switches, for example. The robust profile rail is the basis of SAW linear modules as well as ZLW toothed belt axes and has up to 5 T-slots for mounting slot nuts. Moreover, slot nuts are used as a fastening option in the case of drylin® Q linear carriages. Roll-in slot nuts are available for retrofitting in closed T-slots.

- Fully adjustable
- Ideal for drylin® limit and reference switches
- Suitable for T-slots of the drylin® WSX high-profile rail
- Secure retention
- Can be retrofitted

| Part No.  | Suitable for rail profile | Linear module                        |
|-----------|---------------------------|--------------------------------------|
| NOR-20602 | WSX-06-30                 | SAW-0630, SAWC-0630, ZLW-0630        |
| NOR-20602 | WSX-10-40                 | SAW-1040, SAWC-1040, ZLW-1040        |
| NOR-20602 | WSX-10-80                 | SAW-1080, ZLW-1080                   |
| NOR-20602 | AWMQ-20                   | QWE-01-20                            |
| NOR-20602 | WSX-16-60                 | SAW-1660, ZLW-1660 (lateral grooves) |
| NOR-20605 | WSX-16-60                 | SAW-1660, ZLW-1660 (lower groove)    |
| NOR-20615 | AWMQ-12                   | QWE-01-12                            |

## Dimensions [mm]

| Part No.                  | A    | B    | B1 | H  | H1 | G  | R   |
|---------------------------|------|------|----|----|----|----|-----|
| NOR-20602                 | 9.0  | 19.0 | 4  | 4  | –  | M5 | –   |
| NOR-20605                 | 15.0 | 15.0 | 10 | 12 | 6  | M8 | –   |
| NOR-20613 <sup>132)</sup> | 5.2  | 9.5  | –  | 4  | –  | M4 | 2.5 |

<sup>132)</sup> Optionally available: roll-in slot nut for retrofitting



## Clamping elements for linear modules and toothed belt axes



Fixing clamps offer a safe fastening of the drylin® linear axes on aluminium profiles. Designed for the drylin® W high-profile rail, the clamps can be inserted into the slots of the rail and used to fix the axis in place.

- Secure mounting
- Fully adjustable
- For drylin® SAW linear modules and ZLW toothed belt axes
- For drylin® WSX high-profile rails

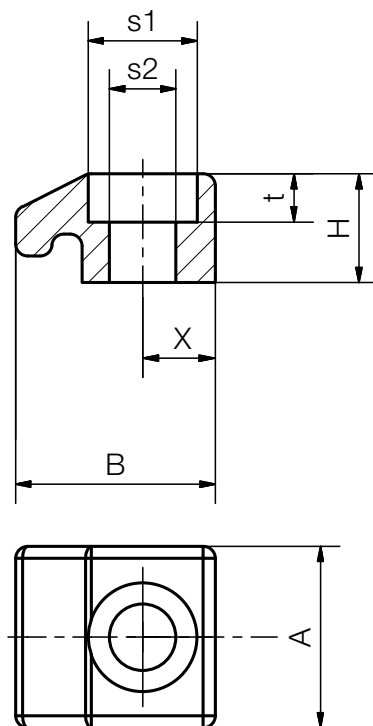

| Part No.   | Suitable for toothed belt axis |
|------------|--------------------------------|
| ZTZ-063006 | ZLW-0630                       |
| 75.40-ZLW  | ZLW-1040                       |
| 75.40-ZLW  | ZLW-1080                       |
| 75.50-ZLW  | ZLW-1660                       |

## Dimensions [mm]

| Part No.   | B     | A  | H    | X    | s1 | s2  | t |
|------------|-------|----|------|------|----|-----|---|
| ZTZ-063006 | 16.5  | 15 | 9.0  | 6.0  | 9  | 5.5 | 4 |
| 75.40-ZLW  | 27.65 | 40 | 8.7  | 8.6  | -  | 6.4 | - |
| 75.50-ZLW  | 37.25 | 40 | 14.4 | 11.0 | -  | 9.0 | - |

## Adapter plate - variable arrangement of accessories



- Adapter plate for manual orientation of position indicators and manual clamps
- Suitable for drylin® linear modules of the SLW/SHT/SHTP series
- Material: Plastic

 **Installation note: Unused sections can be easily separated.**

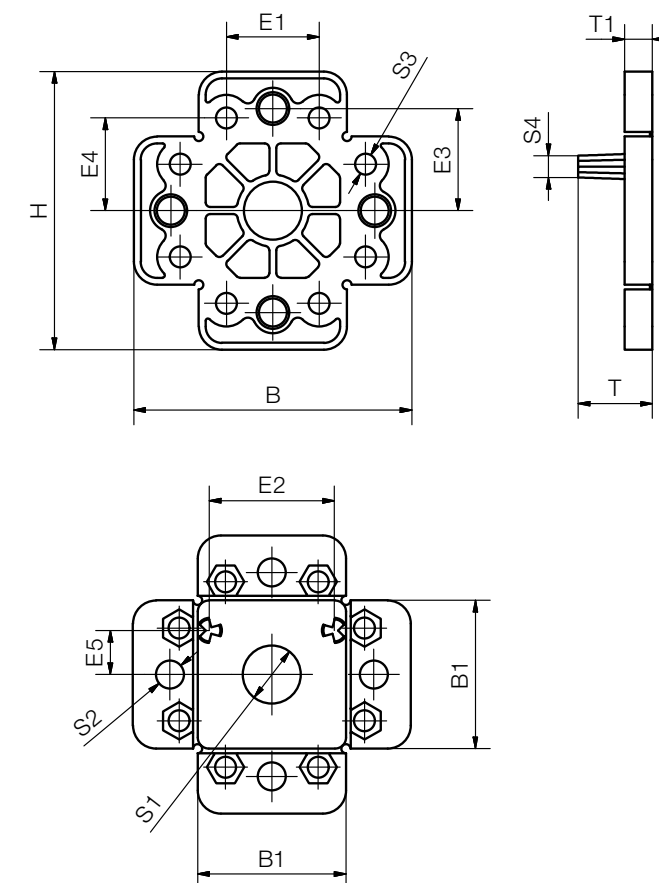

| Part No.   | Suitable for linear module               |
|------------|--|
| STZ-063008 | SLW-0630/SHTP-06                         |
| STZ-104001 | SLW-1040/SHT-12<br>SHT-20, SHTP-01/02-12 |
| STZ-166001 | SLW-1660                                 |
| STZ-208001 | SLW-2080, SLW-25120                      |
| STZ-302403 | SHT-30                                   |

## Dimensions [mm]

| Part No.   | H  | B  | B1 | T  | T1 | E1 | E2                      | E3 | E4 | E5      | S1   | S2 | S3  | S4   |
|------------|----|----|----|----|----|----|-------------------------|----|----|---------|------|----|-----|------|
| STZ-063008 | 48 | 48 | 18 | 8  | 5  | -  | 14.4/11 <sup>106)</sup> | 18 | -  | 7.2/5.5 | 8.5  | 6  | -   | Ø1.5 |
| STZ-104001 | 60 | 60 | 32 | 16 | 6  | 20 | 27                      | 22 | 20 | 9.5     | 12.5 | 6  | 4.5 | M6   |
| STZ-166001 | 60 | 71 | 32 | 20 | 6  | 20 | 58                      | 22 | 20 | 4.5     | 14.5 | 6  | 4.5 | Ø11  |
| STZ-208001 | 60 | 71 | 32 | 16 | 6  | 20 | 58                      | 22 | 20 | 13.0    | 14.5 | 6  | 4.5 | M10  |
| STZ-302403 | 60 | 60 | 32 | 16 | 6  | 20 | 27                      | 22 | 20 | 9.5     | 14.5 | 6  | 4.5 | M6   |

<sup>106)</sup> Adapter plate with 8 pins

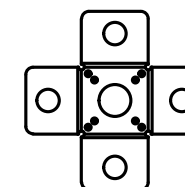

Position indicators and lead screw clamps available ► Page 618

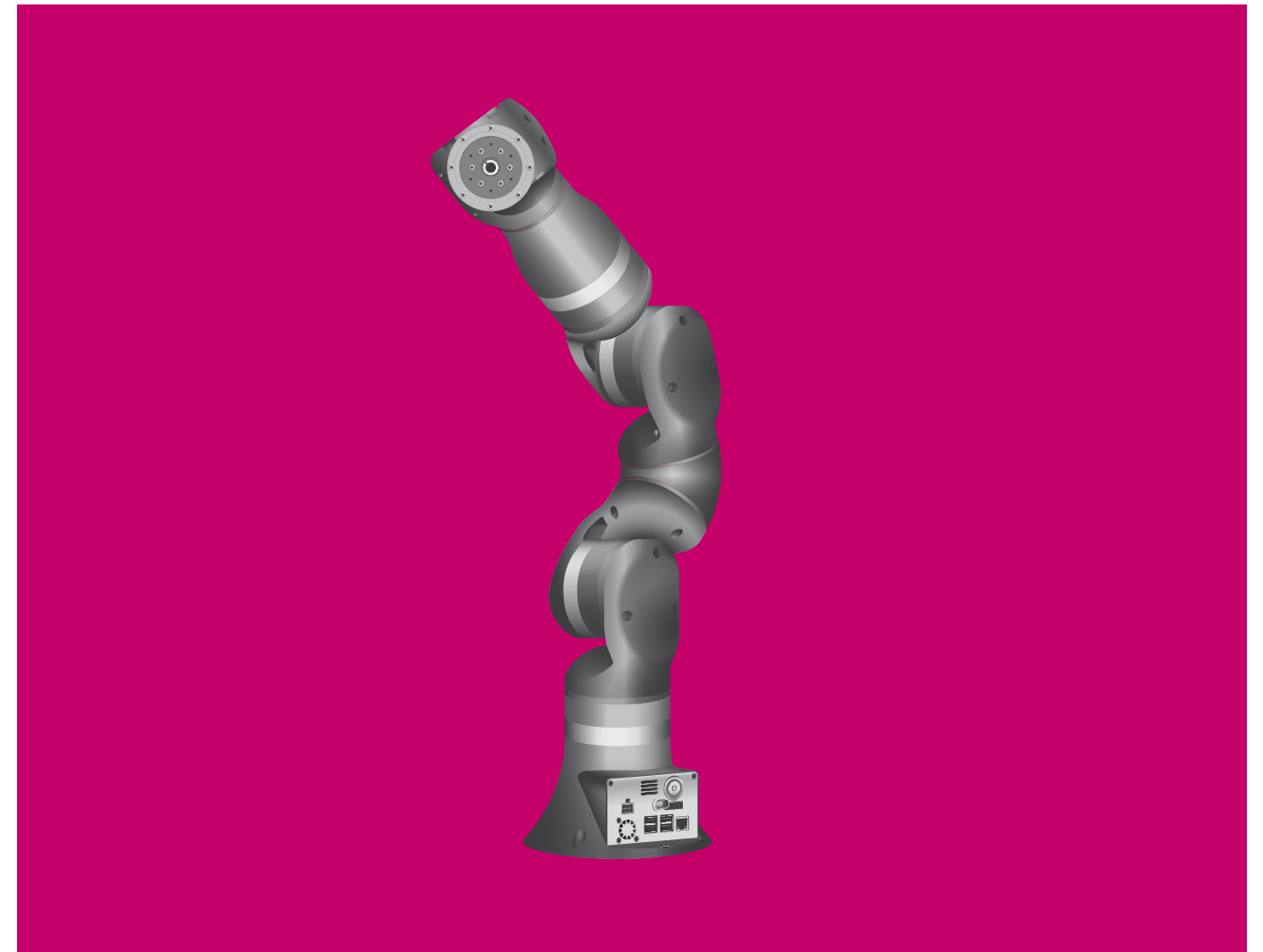

## Low Cost Automation

Cobots

Articulated arm robot

Linear robots

Delta robot

SCARA robot

Control system/software

Accessories

Robot modular gearbox system



## Cobots and articulated arm robots



New

Robot arm for service robots:  
 robotlink® ReBeL®  
 ▶ Page 698



New

Fully integrated strain wave gear for cobots:  
 robotlink® ReBeL®  
 ▶ Page 699



Robot arm - small option:  
 robotlink® RL-DC  
 ▶ Page 700



Robot arm - large option:  
 robotlink® RL-DP  
 ▶ Page 701



New

Splash-proof 5-axis robots:  
 robotlink® RL-DP-SW  
 ▶ Page 702

## Linear robots



Line robot:  
 for vertical working planes  
 DLE-LG  
 ▶ Page 704

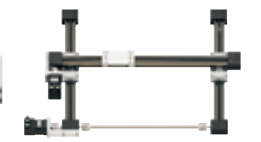

Flat linear robot:  
 for predefined surfaces  
 DLE-FG  
 ▶ Page 705

## Linear robots

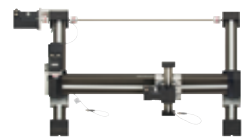

Room linear robot:  
 for three dimensional applications - DLE-RG  
 ▶ Page 706

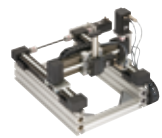

Individual linear robots:  
 custom linear robots with no minimum order quantity  
 ▶ Page 707



Delta robot  
 with 3-axis kinematics  
 ▶ Page 708



New

Delta robot  
 with 2-axis kinematics  
 ▶ Page 710



Lift/turn unit,  
 linear and rotating:  
 drylin® HSQ  
 ▶ Page 712



Torque-resistant linear module, controlled separately:  
 drylin® SLQ  
 ▶ Page 713

## SCARA robot



New

Robot with three degrees of freedom:  
 drylin® SCARA  
 ▶ Page 715



New

Robot with four degrees of freedom:  
 drylin® SCARA  
 ▶ Page 716

## SCARA robot



New

4 DOF with cladding:  
 drylin® SCARA  
 ▶ Page 717



Modular control and software  
 igus® Robot Control  
 ▶ Page 718



New

Adapter kits:  
 seventh axis for robots  
 ▶ Page 720



New

Adapter kits:  
 rotary axis for robots  
 ▶ Page 721



New

Robot cells for all igus® robots  
 ▶ Page 722

## Robot modular gearbox system



Worm gear with two PRT slewing rings, with plain bearings:  
 robotlink® D  
 ▶ Page 724



Worm gear with one PRT slewing rings, with plain bearings:  
 robotlink® D  
 ▶ Page 725

## Robot modular gearbox system



Worm gear, ball bearing:  
 robotlink® D  
 ▶ Page 726



Worm gear, ball bearing:  
 robotlink® D  
 ▶ Page 727



Robot joint with direct drive:  
 robotlink® D  
 ▶ Page 728



Components with DC motor:  
 robotlink® D  
 ▶ Page 729



Worm gear joints:  
 drygear® Apiro®  
 ▶ Page 730



New

Connection to linear units:  
 drygear® Apiro®  
 ▶ Page 734



New

Robot gear set for eight systems:  
 Apiro® robotics kit  
 ▶ Page 738



Cantilever axis:  
 robotlink® Apiro®  
 ▶ Page 736

## ...further kinematics



New

Planetary gearbox:  
 robotlink® Apiro®  
 ▶ Page 737



New

Strain wave gear output shaft:  
 drygear® strain wave gear  
 ▶ Page 739



New

Planetary gearbox:  
 drygear® planetary gearbox RL-P  
 ▶ Page 740

## Online tools



ReBeL® configurator  
 ▶ Page 694



robotlink® designer  
 ▶ Page 694



Linear robot configurator  
 ▶ Page 694



Online marketplace for Low Cost Robotics  
 RBTX  
 ▶ www.rbt.com



## Low Cost Automation

Low Cost Automation stands for significant increase in productivity processes with the help of a simple and affordable automation in the form of robotics components. Depending on the application, automation processes can be automated in whole or in part. At igus® you have everything you need for cost-effective process automation from a single source: complete robot arms, individual components for customised solutions or to expand existing applications, and a control system suited to robolink® with intuitive software.

- Maintenance-free dry operation
- Quiet
- Resistance to dust and dirt
- Corrosion-free
- Standard product range available in within 24hrs
- Free consultation and installation at your premises
- Feasibility check in the Customer Testing Area (CTA)

### Typical application areas

- Pick & place
- Measurement and testing
- Labelling technology
- Component marking
- Assembly cells
- Sorting machines
- Safety systems

 **Available from stock**  
Detailed information about delivery time online.

 **Price breaks online**  
No minimum order value. No minimum order quantity

Fully integrated single joints

Lightweight construction with plastic components

Gearbox modular system for service robotics

Maintenance-free

Can be controlled with igus® Robot Control

Toolmakers and their suppliers are facing major global challenges. The competition is becoming more intense, the price pressure is becoming greater, including the demand for local production. We offer complete cost-effective systems that automate tasks in order to produce faster and more effectively.



### Cobots

- For service tasks
  - With fully integrated strain wave gear
- Page 698



### Articulated arm robot

- Up to 5 DOF (degrees of freedom)
  - Modular and cost-effective
- Page 700



### Linear robots

- Pre-configured assembly kits available from stock
  - 3 different linear robot structures: line/flat/room
- Page 704



### Parallel kinematics

- Kit or pre-installed kinematics
- Page 708



### SCARA robot

- 4 DOF (degrees of freedom)
  - IP44 version possible
- Page 716



### Workspace extension

- Axis 7 for linear movements
  - Rotary axes
- Page 720



### drygear® worm gear

- With PRT or slewing rings with ball bearings
- Page 724



### drygear® Apiro® modular gearbox system

- Tribologically optimised worm gears
  - Motor drive or manual drive
- Page 730



### drygear® strain wave gear and planetary gearbox

- Small compact design
  - Available transmission: 28:1
- Page 739



### igus® Robot Control

- Control system for linear robots, delta robots and robolink® robot arms
- From page 718



### Motor control systems

► From page 662



# Low Cost Automation | Online tools

Calculate and configure robot arms

## Configure your cobot

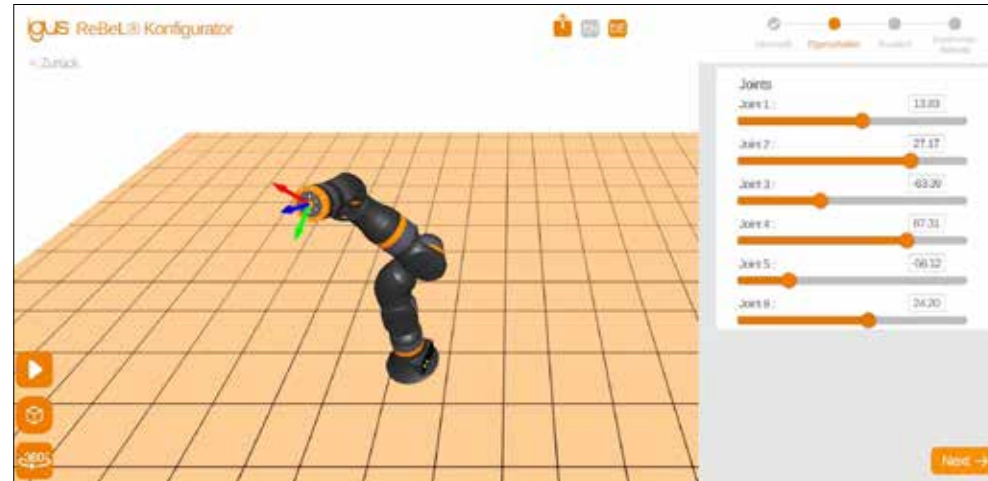

- Configure the igus® ReBeLi® so that it is ready to connect
- Select axes, tools, accessories, and services
- ▶ [www.igus.eu/rebel-configurator](http://www.igus.eu/rebel-configurator)

## robotlink® designer

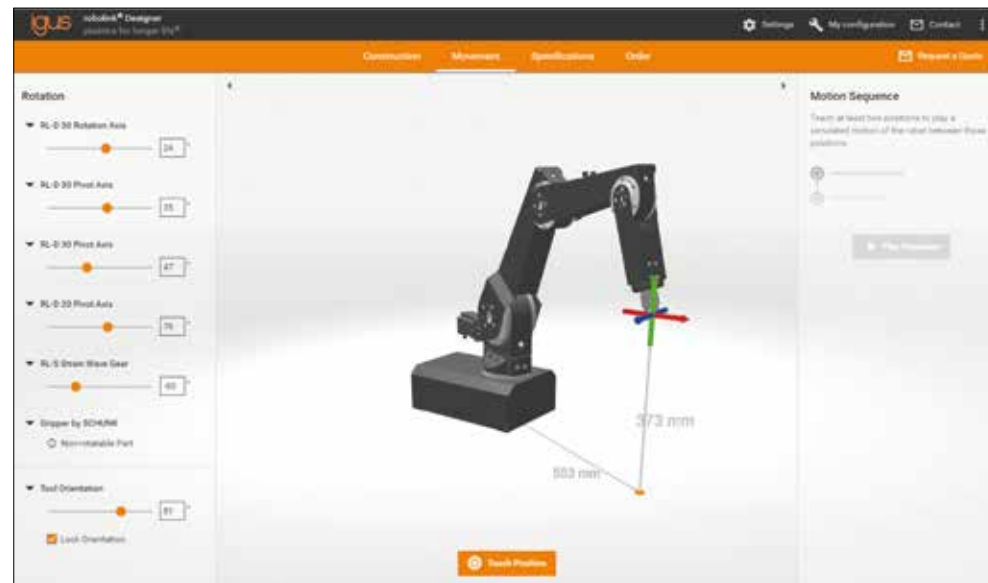

- Configure ready-to-connect units directly in the online tool
- Create your individual robotlink® D robot arm quickly and easily
- Configurations for individual axes to tools
- Simulates the solution with maximum range and payload
- ▶ [www.igus.eu/robotlink-designer](http://www.igus.eu/robotlink-designer)

## Configure individual gantries in no time

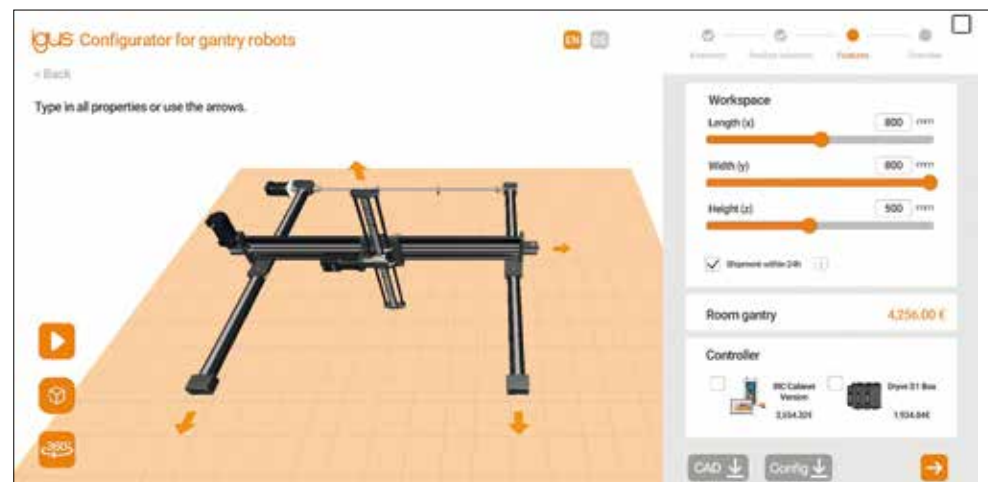

- Quick selection of the appropriate linear robot system
- Configure ready-to-connect units directly in the online tool
- Selection of various control techniques
- All igus® standard linear robots available
- ▶ [www.igus.eu/linear-robot-configurator](http://www.igus.eu/linear-robot-configurator)

# Low Cost Automation

Test in the Customer Testing Area



## You want to be sure about your application's feasibility?

We offer a handling test. Just send us your workpiece/object and we will provide you with a video of our test or show you the feasibility live.

- With accessories such as grippers or vision
- Test directly in the robot cells
- Over 1,000 customer tests
- 400m<sup>2</sup> Customer Testing Area
- Typical applications are pick & place, end of the line quality control or gluing and joining applications.



More information and prices online

▶ [www.igus.eu/customer-testing-area](http://www.igus.eu/customer-testing-area)

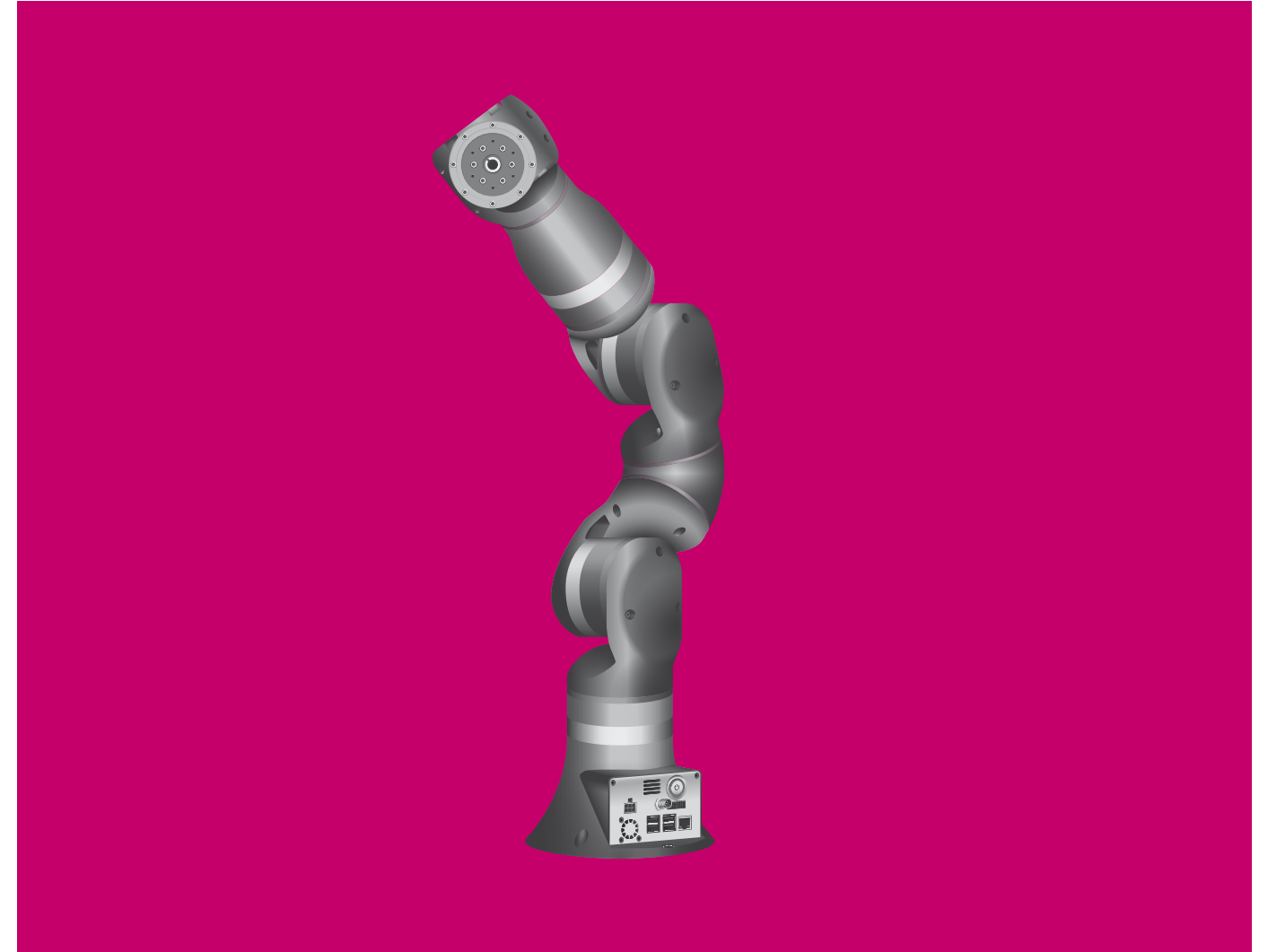
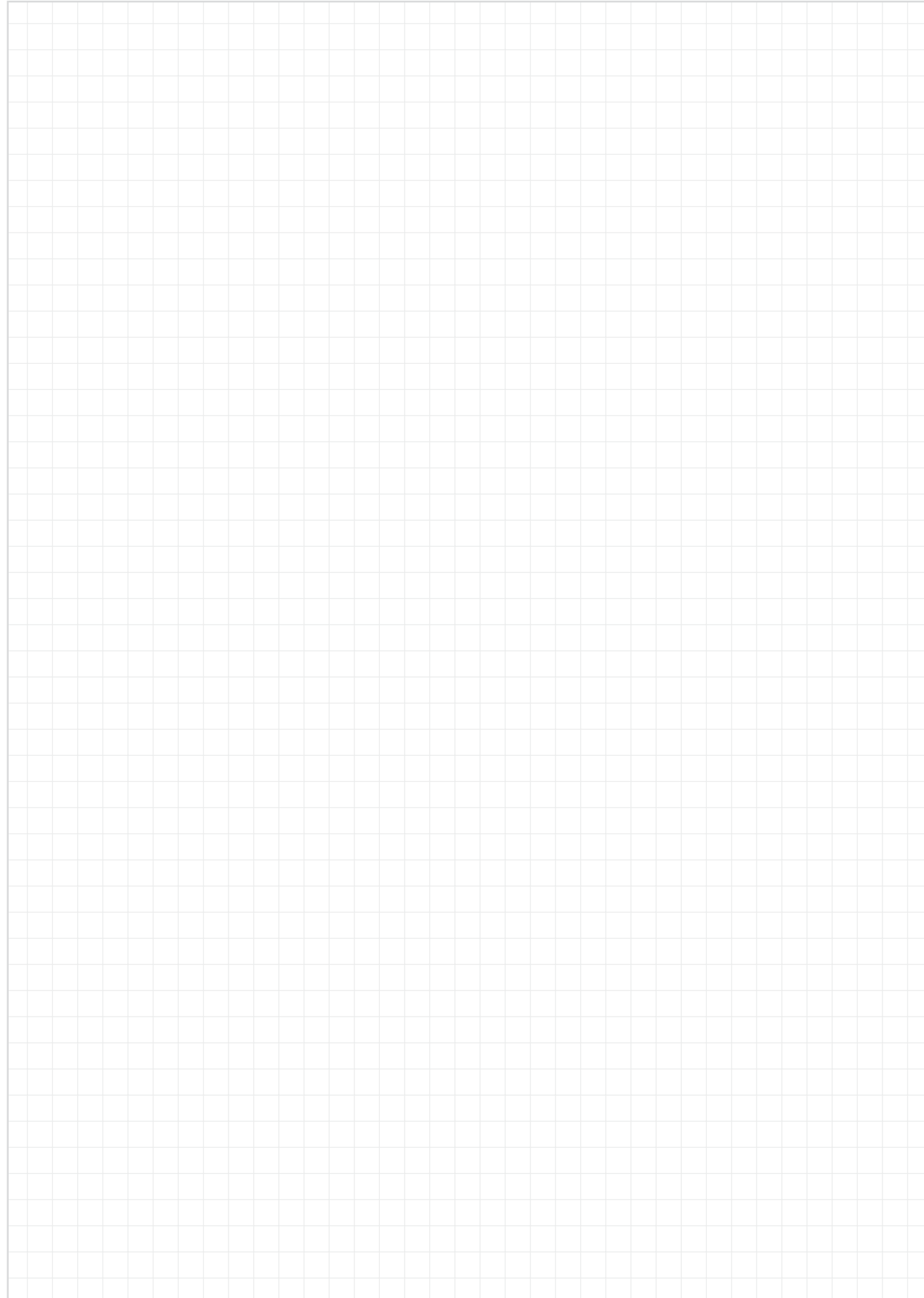

## Articulated arm robot

ReBeL<sup>®</sup> cobot

roboLink<sup>®</sup> DC

roboLink<sup>®</sup> DP

Splash water roboLink<sup>®</sup> DP



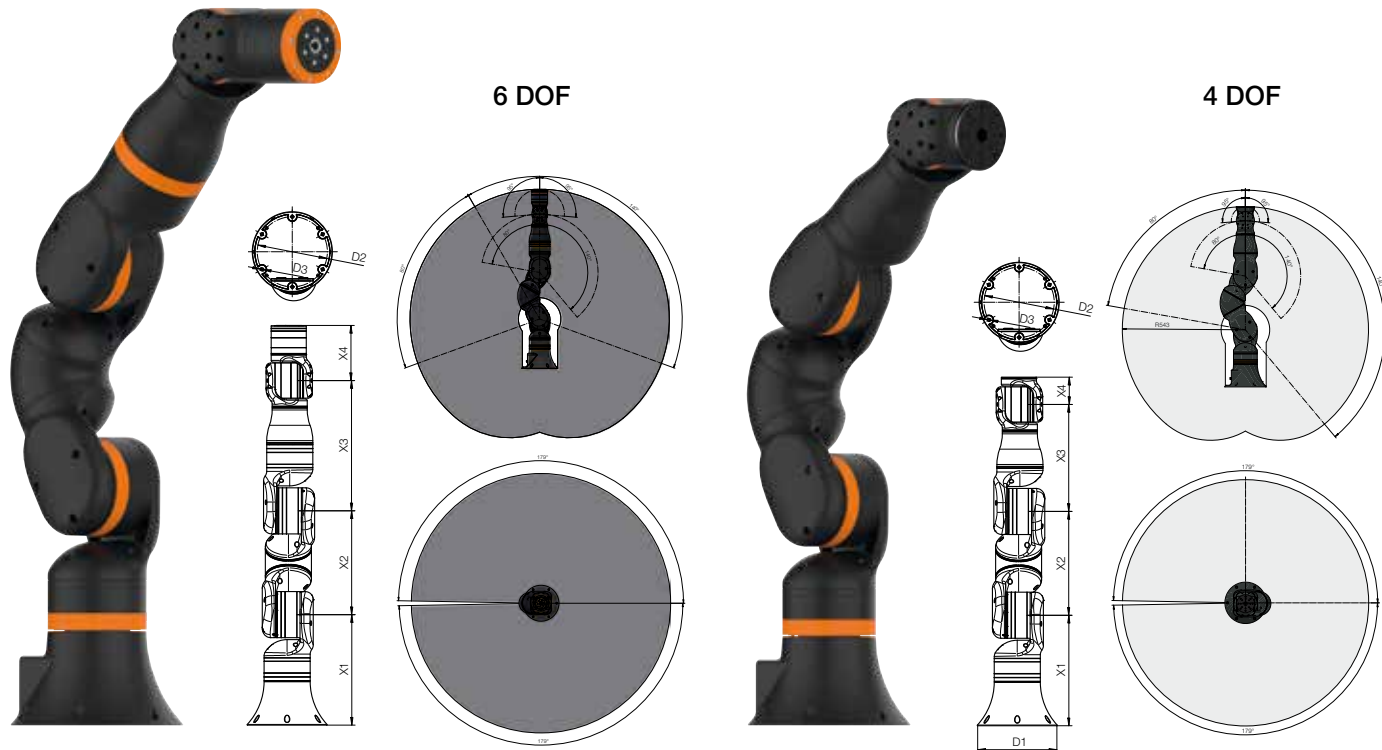

- Prepared for cobot function
- Plug-and-play and open-source variants available
- Assembling aid ► Page 718

Available in 4-6 weeks

Technical data - ReBeL® robot arm

|   | 6 DOF <sup>168)</sup> | 4 DOF <sup>168)</sup> |
|---|-----------------------|-----------------------|
| <b>Kinematics/type</b>                              | Articulated arm robot | Articulated arm robot |
| <b>Application area</b>                             | Service robotics      | Service robotics      |
| <b>Number of axes</b>                               | 6                     | 4                     |
| <b>Total reach</b> [mm]                             | 664                   | 495                   |
| <b>Nominal reach</b> [mm]                           | 400                   | 400                   |
| <b>Joint rotation for axes 1, 4 and 6</b> [°]       | 360                   | 360                   |
| <b>Angular speed</b> [°/s]                          | 45                    | 45                    |
| <b>Final speed TCP (full load)</b> [mm/s]           | 200                   | 200                   |
| <b>Floor space</b> [mm]                             | 180                   | 180                   |
| <b>Ambient temperature</b> [°C]                     | 0-50                  | 0-50                  |
| <b>Dynamics with 500g load capacity</b> [Picks/min] | 7                     | 7                     |
| <b>Payload incl. tool</b> [kg]                      | 2                     | 3                     |
| <b>Repetition accuracy</b> [mm]                     | ±1                    | ±1                    |
| <b>Weight</b> [kg]                                  | < 8                   | < 7                   |
| <b>Plug &amp; play solution with iRC</b>            |                       |                       |
| <b>Part No.</b>                                     | REBEL-6DOF-00         | REBEL-4DOF-00         |
| <b>Open source variant</b>                          |                       |                       |
| <b>Part No.</b>                                     | REBEL-6DOF-OS         | REBEL-4DOF-OS         |

Dimensions [mm]

| Part No.                 | L1  | X1  | X2  | X3  | X4  | a2 | b2    | D1  | D2  | D3  | D4 | D5 | D6 | D7 |
|--------------------------|-----|-----|-----|-----|-----|----|-------|-----|-----|-----|----|----|----|----|
| ReBeL-6DOF-00 <b>New</b> | 660 | 252 | 237 | 297 | 126 | 80 | 138.6 | 180 | 160 | 6.5 | 43 | M3 | -  | -  |
| ReBeL-4DOF-00 <b>New</b> | 543 | 252 | 237 | 244 | 62  | 80 | 138.6 | 180 | 160 | 6.5 | 43 | M3 | 62 | M4 |

<sup>168)</sup> DOF: degree of freedom



RL-SE-105-1-50-AL

RL-SE-80-1-50-AL

- 25% lighter than conventional strain wave gears thanks to igus® high-performance polymers
- Strain wave gear incl. power electronics, driver and encoder
- Minimum service life 1,000,000 cycles
- Direct connections of grippers to flange plate

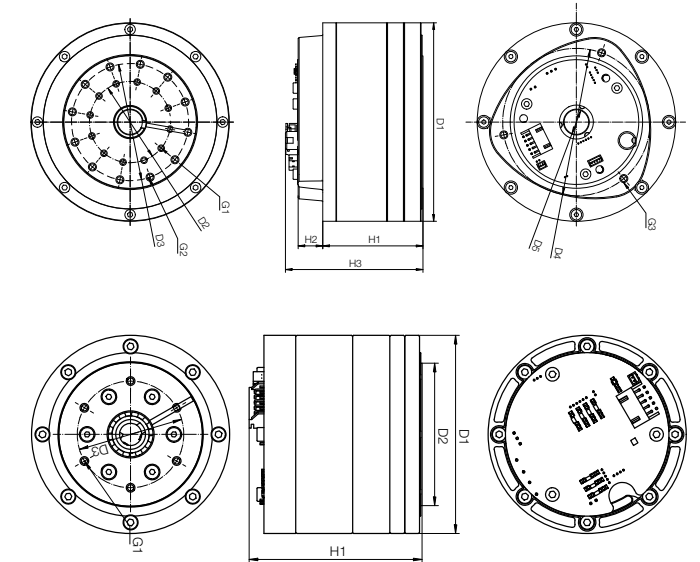

Technical data

| Part No.                     | Outer Ø [mm] | Height [mm] | Max. drive torque [Nm] | Rated torque [Nm] | Output speed [1/min] | Transmission | Weight [g] |
|------------------------------|--------------|-------------|------------------------|-------------------|----------------------|--------------|------------|
| RL-SE-80-1-50-AL <b>New</b>  | 80           | 60          | 2.5                    | 2                 | 6.0                  | 50:1         | 330        |
| RL-SE-105-1-50-AL <b>New</b> | 105          | 62          | 20.5                   | 10                | 6.0                  | 50:1         | 900        |

Control data

| Part No.                     | Nominal voltage Logic [V] | Nominal voltage Motor [V] | Nominal current [A] | Peak current [A] | Communication                   |
|------------------------------|---------------------------|---------------------------|---------------------|------------------|---------------------------------|
| RL-SE-80-1-50-AL <b>New</b>  | 5                         | 24                        | 3                   | 9                | CAN500k with CPR-CANV2 protocol |
| RL-SE-105-1-50-AL <b>New</b> | 5                         | 24                        | 3                   | 9                |                                 |

Dimensions [mm]

| Part No.                     | D1 Ø | D2 Ø | D3 Ø | D4 Ø | D5 Ø | D6 Ø | H1   | H2 | H3 | G1 | G2 | G3 |
|------------------------------|------|------|------|------|------|------|------|----|----|----|----|----|
| RL-SE-80-1-50-AL <b>New</b>  | 80   | 57.5 | 43   | 71   | -    | -    | 58.8 | -  | -  | M3 | M3 | -  |
| RL-SE-105-1-50-AL <b>New</b> | 105  | 43.0 | 62   | 78   | 17   | 13   | 49.0 | 52 | 13 | M3 | M4 | M3 |

Available in 1-2 weeks



## Robot arm - small option



Small option

With integrated control system



Test the software free of charge

- Payload up to 10N
- Cycle times > 6s
- Reach up to 680mm
- Integrated gearbox
- With motor encoder
- Available as 4 DOF or 5 DOF<sup>168)</sup>
- Optimised bearing of the single axes for minimal backlash
- Black standard colour, individual colour and logo possible
- Available as a plug-and-play solution with igus® Robot Control
- More configuration options online

► [www.igus.eu/DC](http://www.igus.eu/DC)

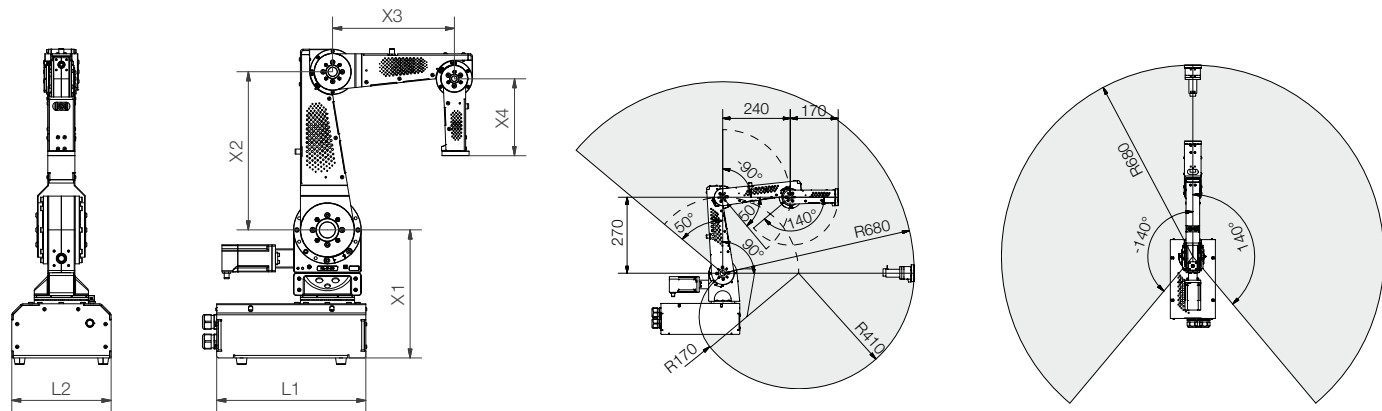

### Technical data - small option (RL-DC)

| Part No.   | 4 DOF <sup>168)</sup> |                   | 5 DOF <sup>168)</sup> |                   |
|--|-----------------------|-------------------|-----------------------|-------------------|
|  | RL-D-RBT-3322-BF      | RL-D-RBT-3322S-BF | RL-D-RBT-3322S-BF     | RL-D-RBT-3322S-BF |
| Operating voltage                                | [VDC]                 | 24                | 24                    | 24                |
| Nominal power (at full load)                     | [W]                   | 120               | 120                   | 120               |
| Weight (without power supply unit, ext. display) | [kg]                  | 11                | 12                    | 12                |
| Precision (WDH precision)                        | [mm]                  | ±0.5              | ±0.5                  | ±0.5              |
| Max. speed (TCP)                                 | [mm/s]                | 100               | 100                   | 100               |
| Reach  | [mm]                  | 600               | 680                   | 680               |
| Payload  | [N]                   | 10                | 5                     | 5                 |
| <b>With integrated control system</b>            |                       |                   |                       |                   |
| Part No.   |                       | RL-DCi-4S-M-B     | RL-DCi-5S-M-B         |                   |

### Articulated arm dimensions [mm]

| Part No.             | L1  | L2  | X1    | X2  | X3  | X4  |
|----------------------|-----|-----|-------|-----|-----|-----|
| RL-D-RBT-3322-BF     | 280 | 160 | 217.5 | 270 | 240 | 170 |
| RL-D-RBT-3322-BF-AE  | 280 | 160 | 227.5 | 270 | 240 | 170 |
| RL-D-RBT-3322S-BF    | 330 | 220 | 273.5 | 350 | 270 | 170 |
| RL-D-RBT-3322S-BF-AE | 330 | 220 | 283.5 | 350 | 270 | 170 |

For more information, see the technical data sheet ► [www.igus.eu/DC](http://www.igus.eu/DC)

<sup>168)</sup> DOF: degree of freedom

## Robot arm - large option



Large option

With integrated control system



Test the software free of charge

- Payload up to 30N
- Cycle times > 6s
- Up to 790mm of reach
- Integrated gearbox
- With motor encoder
- Available as 4 DOF or 5 DOF<sup>168)</sup>
- Optimised bearing of the single axes for minimal backlash
- Black standard colour, individual colour and logo possible
- Available as a plug-and-play solution with igus® Robot Control
- More configuration options online

► [www.igus.eu/DP](http://www.igus.eu/DP)

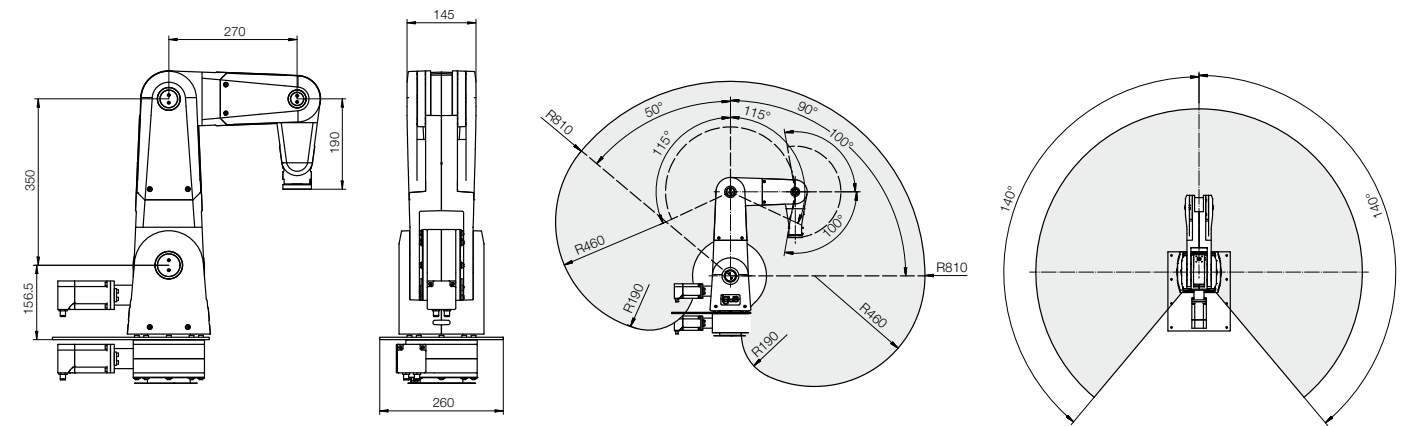

### Technical data - large option (RL-DP)

| Part No.   | 4 DOF <sup>168)</sup> |                      | 5 DOF <sup>168)</sup> |         |
|--|-----------------------|----------------------|-----------------------|---------|
|  | RL-DP-4               | RL-DP-5              | RL-DP-4               | RL-DP-5 |
| Operating voltage                                | [VDC]                 | 24                   | 24                    | 24      |
| Nominal power (at full load)                     | [W]                   | 120                  | 120                   | 120     |
| Weight (without power supply unit, ext. display) | [kg]                  | 22                   | 23                    | 23      |
| Precision (WDH precision)                        | [mm]                  | ±0.5                 | ±0.5                  | ±0.5    |
| Max. speed (TCP)                                 | [mm/s]                | 100                  | 100                   | 100     |
| Reach  | [mm]                  | 790                  | 790                   | 790     |
| Payload  | [N]                   | 30                   | 30                    | 30      |
| <b>With integrated control system</b>            |                       |                      |                       |         |
| With top hat (DIN) rail                          |                       | RL-DP-4-24-0002-00-0 | RL-DP-5-24-0002-00-0  |         |
| With control cabinet                             |                       | RL-DP-4-24-0004-00-0 | RL-DP-5-24-0004-00-0  |         |



Small and large options:  
Black standard colour, individual colour and logo possible

<sup>168)</sup> DOF: degree of freedom

For more information, see the technical data sheet ► [www.igus.eu/DP](http://www.igus.eu/DP)



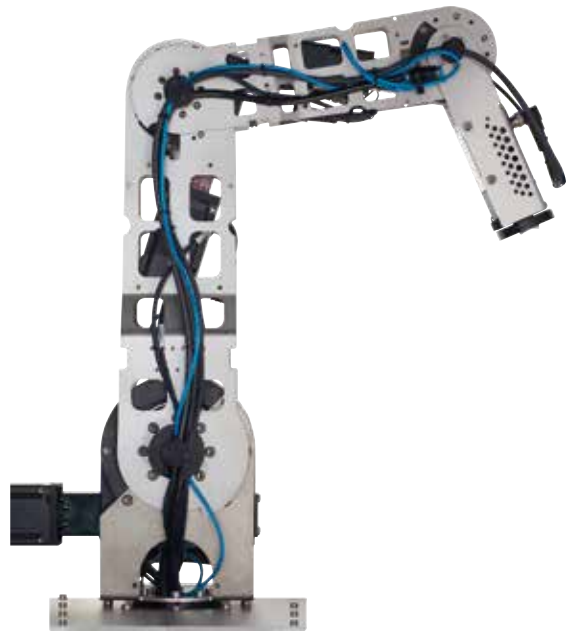

- Splash-proof thanks to protection class IP 44
- Tribologically optimised robot joints
- Joining links made of stainless steel
- Software available free of charge
- igus® Robot Control ▶ Page 718



Test the software free of charge

Technical data

|                           |             | 4 DOF <sup>168)</sup>   | 5 DOF <sup>168)</sup>   |
|---------------------------|-------------|-------------------------|-------------------------|
| Part No.                  |             | RL-DP-4-SW-24           | RL-DP-5-SW-24           |
| Payload                   | [N]         | 20                      | 20                      |
| Speed                     | [Picks/min] | 7                       | 7                       |
| Workspace                 | [mm]        | 790                     | 790                     |
| Nominal reach             | [mm]        | 450                     | 450                     |
| Weight                    | [kg]        | 23.6                    | 23.6                    |
| Payload                   | [kg]        | 2                       | 3                       |
| Precision (repeatability) | [mm]        | ±0.5                    | ±0.5                    |
| Max. speed (TCP)          | [m/s]       | 0.2                     | 0.2                     |
| Ambient temperature       | [°C]        | 0 to +50                | 0 to +50                |
| With top hat (DIN) rail   |             | RL-DP-4-SW-24-0002-00-0 | RL-DP-5-SW-24-0002-00-0 |
| With control cabinet      |             | RL-DP-4-SW-24-0004-00-0 | RL-DP-5-SW-24-0004-00-0 |

 For more information, see the technical data sheet  
▶ [www.igus.eu/DP](http://www.igus.eu/DP)

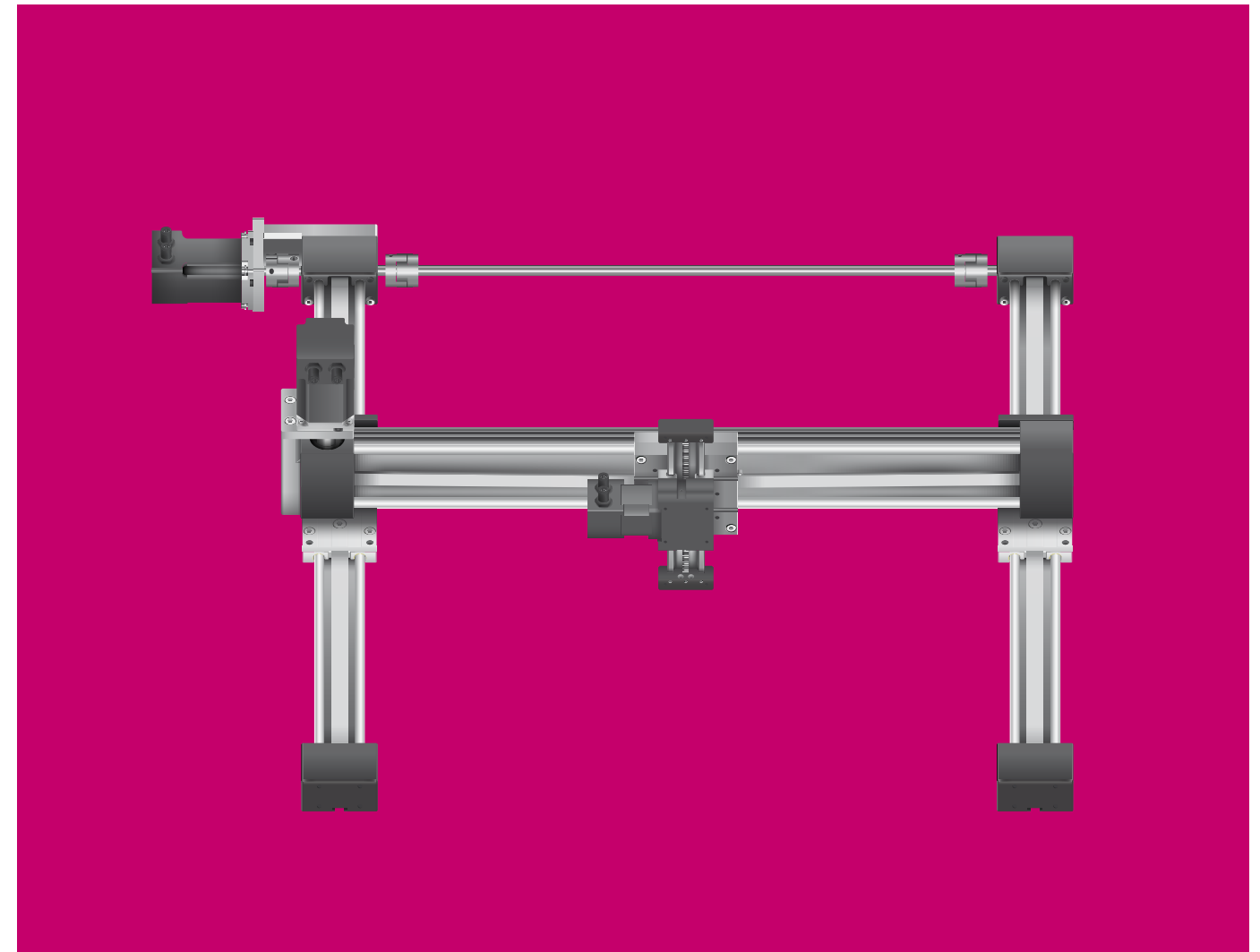

## Linear robots and other kinematics

Linear robots

Delta robot

SCARA robot

Further kinematics

Accessories

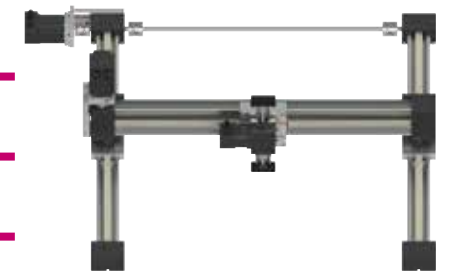

<sup>168)</sup> DOF: degree of freedom

## Linear robot - for vertical working planes

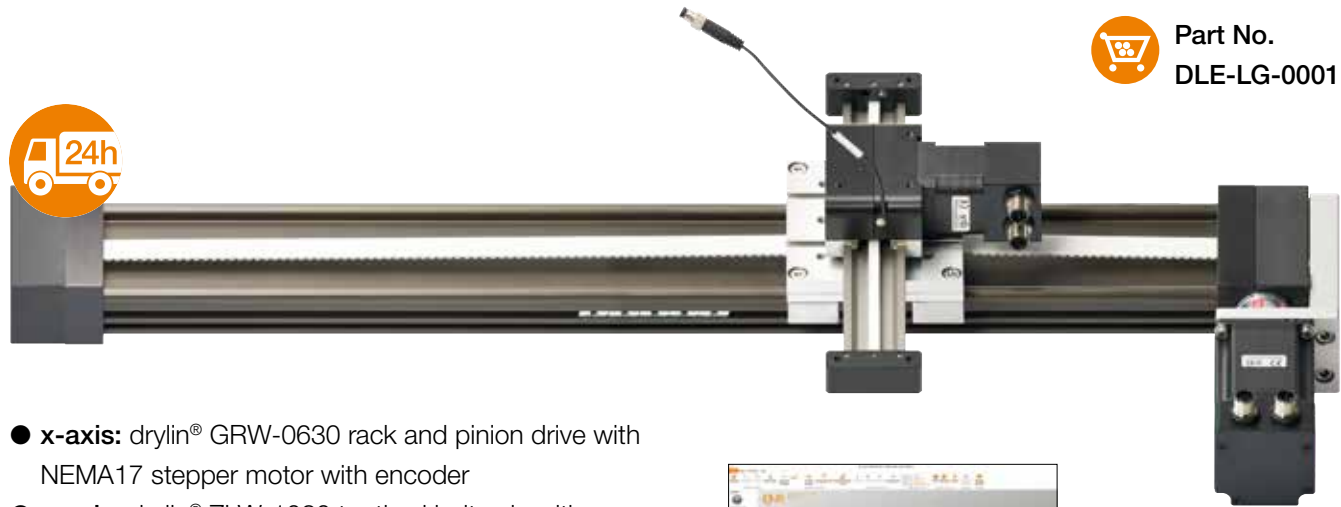

- **x-axis:** drylin® GRW-0630 rack and pinion drive with NEMA17 stepper motor with encoder
- **y-axis:** drylin® ZLW-1080 toothed belt axis with NEMA23 stepper motor with encoder
- Proximity switches, connection cables, control systems and other installation sizes upon request



igus® Robot Control  
► From page 718

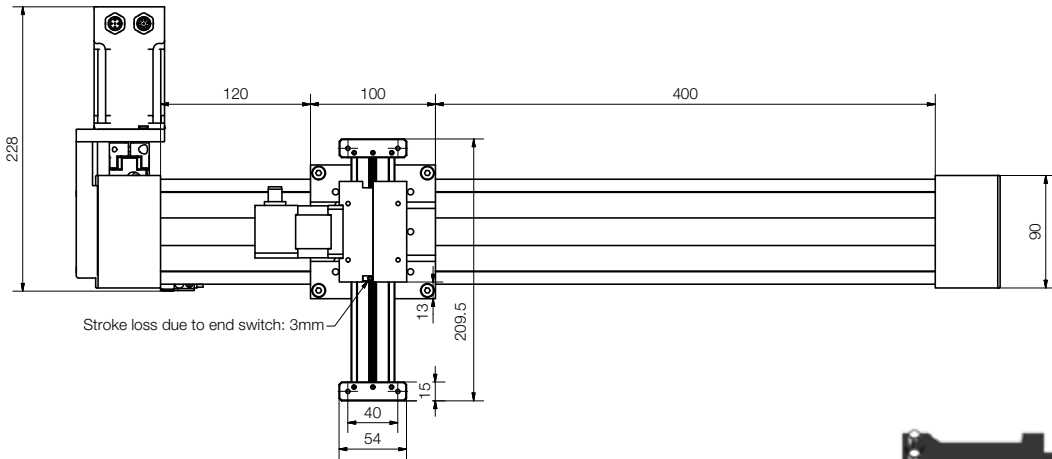

- **y-axis:** drylin® ZLW-10120 toothed belt axis with NEMA 23 XL stepper motor with encoder
- **z-axis:** GRR-1280 rack axis with NEMA23 XL stepper motor with encoder
- Proximity switches and motor cables available

Part No.  
DLE-LG-0002

### Technical data

|                           |                     | DLE-LG-0001 | DLE-LG-0002 |
|---------------------------|---------------------|-------------|-------------|
| Workspace <sup>181)</sup> | [mm]                | 500 x 100   | 800 x 500   |
| Max. speed                | [m/s]               | 1.0         | 1.0         |
| Max. acceleration         | [m/s <sup>2</sup> ] | 3.0         | 2.0         |
| Repeatability             | [mm]                | 0.2         | 0.3         |
| Max. load capacity        | [N]                 | 25.0        | 50.0        |

<sup>181)</sup> Customised stroke length upon request

## Flat linear robot - for predefined surfaces



- Part No.  
DLE-FG-0001 version with encoder
- DLE-FG-0002 version with stranded wire
- DLE-FG-0003 econ version
- DLE-FG-0005 version with encoder
- DLE-FG-0006 version with encoder



igus® Robot Control  
► From page 718

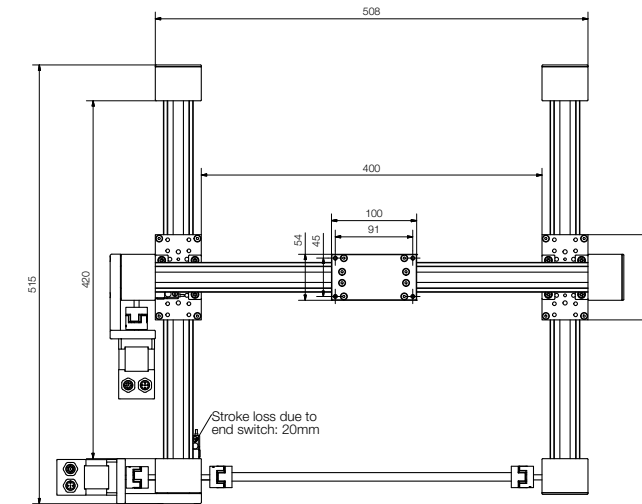

### DLE-FG-0001

- **x-axis:** drylin® ZLW-0630 toothed belt axis with NEMA17 stepper motor with encoder
- **y-axis:** drylin® ZLW-0630 toothed belt axis with NEMA17 stepper motor with encoder
- Proximity switches, connection cables, control systems and other installation sizes upon request

### DLE-FG-0002

- **x-axis:** drylin® ZLW-0630 toothed belt axis with NEMA17 stepper motor with stranded wire
- **y-axis:** drylin® ZLW-0630 toothed belt axis with NEMA17 stepper motor with stranded wire
- Proximity switches, connection cables, control systems and other installation sizes upon request

### DLE-FG-0003

- **x-axis:** drylin® ZLW-1040 econ toothed belt axis with NEMA23 stepper motor with stranded wire
- **y-axis:** drylin® ZLW-1040 econ toothed belt axis with NEMA17 stepper motor
- Proximity switches, connection cables, control systems and other installation sizes upon request

### DLE-FG-0005

- **x-axis:** drylin® ZLW-1040-B toothed belt axis, NEMA23 stepper motor with encoder
- **y-axis:** drylin® ZLW-1040-B toothed belt axis, NEMA23 stepper motor with encoder
- **Accessories (supplied loose):** mounting plates, connecting shaft, couplings, clamps
- Proximity switches, connection cables, control systems and other installation sizes upon request

### DLE-FG-0006

- **x-axis:** drylin® ZLW-1040S toothed belt axis, NEMA23 XL stepper motor with encoder
- **y-axis:** drylin® ZLW-1080S toothed belt axis, NEMA23 stepper motor with encoder
- With proximity switches and connecting cables
- Control systems and other installation sizes available

### Technical data

|                           |                     | DLE-FG-0001 | DLE-FG-0002 | DLE-FG-0003 | DLE-FG-0005 | DLE-FG-0006 |
|---------------------------|---------------------|-------------|-------------|-------------|-------------|-------------|
| Workspace <sup>181)</sup> | [mm]                | 300 x 300   | 300 x 300   | 500 x 500   | 500 x 500   | 650 x 650   |
| Max. speed                | [m/s]               | 1.5         | 1.5         | 0.5         | 1.0         | 1.0         |
| Max. acceleration         | [m/s <sup>2</sup> ] | 10.0        | 10.0        | 1.0         | 1.0         | 1.0         |
| Repeatability             | [mm]                | 0.3         | 0.3         | 1.0         | 0.5         | 0.5         |
| Max. load capacity        | [N]                 | 80.0        | 80.0        | 10.0        | 80.0        | 100.0       |

<sup>181)</sup> Customised stroke length upon request

# Low Cost Automation | Product range

## Room linear robot - for three dimensional applications

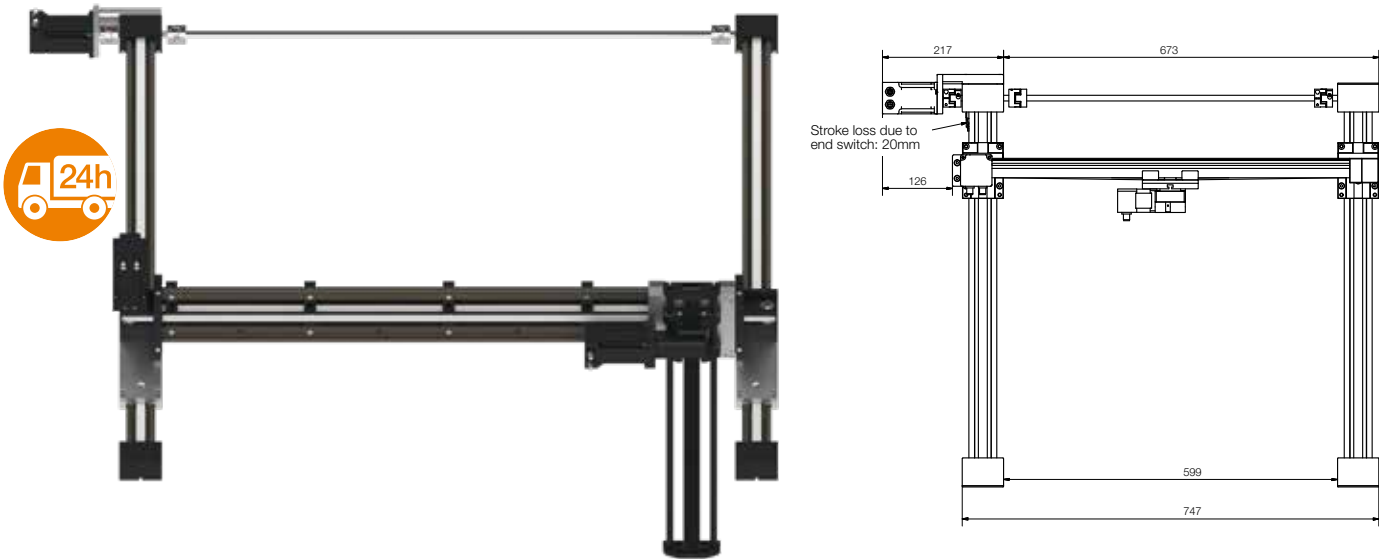

- Part No.**
- DLE-RG-0001
  - DLE-RG-0002
  - DLE-RG-0003
  - DLE-RG-0004



igus® Robot Control  
► From page 718

### DLE-RG-0001

- **x-axis:** drylin® ZLW-1040 toothed belt axis with NEMA23 stepper motor with encoder
- **y-axis:** drylin® ZLW-1080 toothed belt axis with NEMA23 stepper motor with encoder
- **z-axis:** drylin® GRW cantilever axis with rack and pinion drive and NEMA17 stepper motor with encoder
- Proximity switches, connection cables, control systems and other installation sizes upon request

### DLE-RG-0002

- **x-axis:** drylin® ZLW-0630 toothed belt axis with NEMA23 XL stepper motor with encoder
- **y-axis:** drylin® ZLW-0660 toothed belt axis with NEMA23 stepper motor with encoder
- **z-axis:** drylin® GRW-0630 cantilever axis with NEMA17 stepper motor with encoder
- Proximity switches, connection cables, control systems and other installation sizes upon request

### DLE-RG-0003

- **x-axis:** drylin® ZLW-1040 toothed belt axis with NEMA23 XL stepper motor with encoder
- **y-axis:** drylin® ZLW-10120 toothed belt axis with NEMA23 XL stepper motor with encoder
- **z-axis:** GRR-1280 rack axis with NEMA23 XL stepper motor with encoder
- Proximity switches, connection cables, control systems and other installation sizes upon request

### DLE-RG-0004

- **x-axis:** drylin® ZLW-20120S with NEMA24 stepper motor and 3:1 gearbox
- **y-axis:** drylin® ZLW-20200S with NEMA24 stepper motor and 3:1 gearbox
- **z-axis:** 1 x GRR-20120 rack axis with NEMA24 stepper motor
- Proximity switches, connection cables, control systems and other installation sizes upon request

### Technical data

|                           |                     | DLE-RG-0001     | DLE-RG-0002     | DLE-RG-0003     | DLE-RG-0004           |
|---------------------------|---------------------|-----------------|-----------------|-----------------|-----------------------|
| Workspace <sup>181)</sup> | [mm]                | 500 x 500 x 100 | 400 x 400 x 150 | 800 x 800 x 500 | 2,000 x 2,000 x 1,000 |
| Max. speed                | [m/s]               | 0.5             | 0.5             | 0.5             | 0.5                   |
| Max. acceleration         | [m/s <sup>2</sup> ] | 1.5             | 1.5             | 1.5             | 1.0                   |
| Repeatability             | [mm]                | 0.8             | 0.8             | 0.8             | 0.8                   |
| load capacity             | [N]                 | 25.0            | 25.0            | 50.0            | 100.0                 |

<sup>181)</sup> Customised stroke length upon request

# Low Cost Automation | Product range

## Individual linear robots

### Customised linear robots from 1 piece

In addition to the two standard sizes in the online shop, special linear robots can be tailored to individual customer requirements. Contact us!

► [www.igus.eu/special-linear-robot](http://www.igus.eu/special-linear-robot)

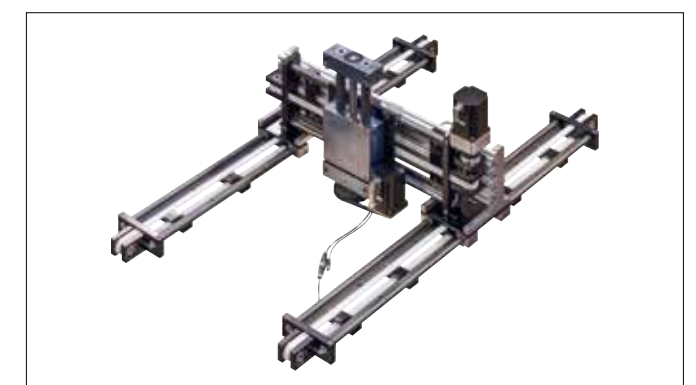
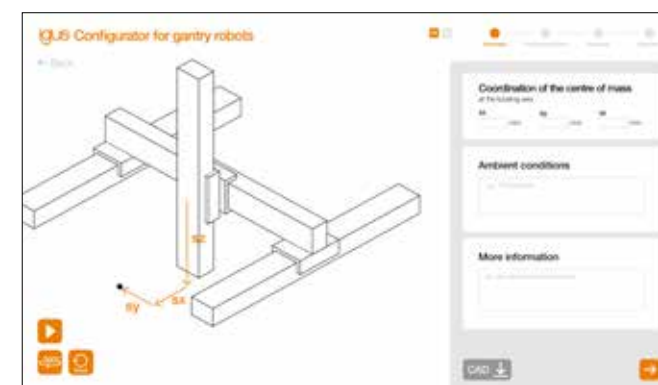
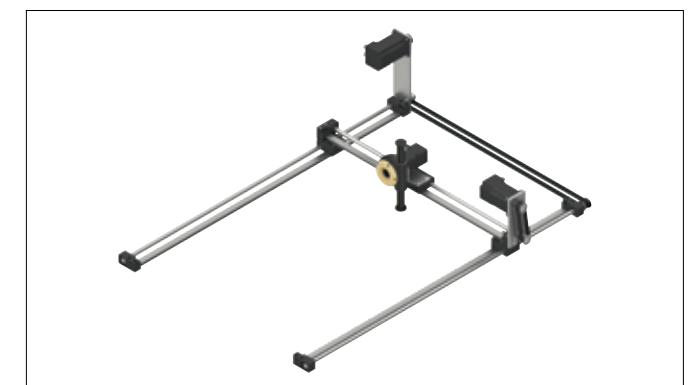
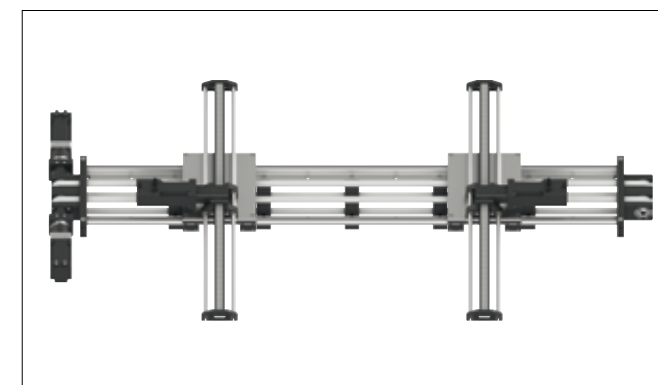
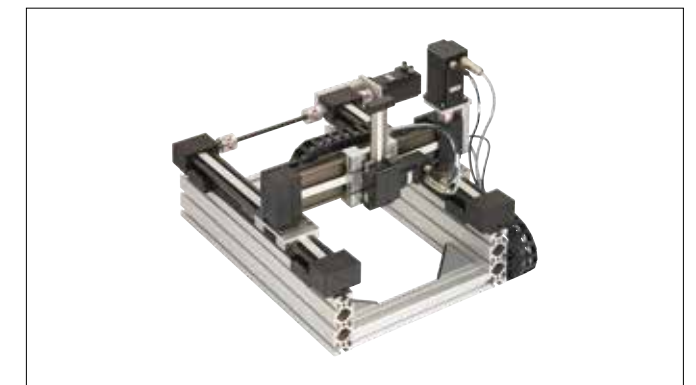

► [www.igus.eu/linear-robot-configurator](http://www.igus.eu/linear-robot-configurator)



## Delta robot



Delta robot consisting of:

- 3 drylin® toothed belt axis with NEMA23 XL stepper motor with encoder
- Lightweight igubal® delta kinematics
- Mounting brackets for mounting in a frame and possibilities of adaptation for grippers/motor
- As a construction kit or completely pre-assembled in a transport rack
- Optional accessories: initiator kits, motor encoders and sensor cables
- Ready for connection with stepper motors for dryve D1 motor control system or as plug & play with the igus® Robot Control

### Technical data

| Part No.                         |             | Delta 01    | Delta 02    |
|----------------------------------|-------------|-------------|-------------|
|                                  |             | DLE-DR-0001 | DLE-DR-0050 |
| Positioning accuracy             | [mm]        | ± 0.5       | ± 0.5       |
| Working area diameter at 75mm    | [mm]        | 360         | 660         |
| Max. payload                     | [kg]        | 5           | 5           |
| Max. process force at radius 0mm | [N]         | 100         | 100         |
| Dynamics at 500g                 | [Picks/min] | Min. 60     | Max. 30     |
| Weight                           | [kg]        | 15          | 16          |
| Track speed                      | [m/s]       | 3           | 0.7         |
| Max. acceleration                | [m/s²]      | 60          | 2           |

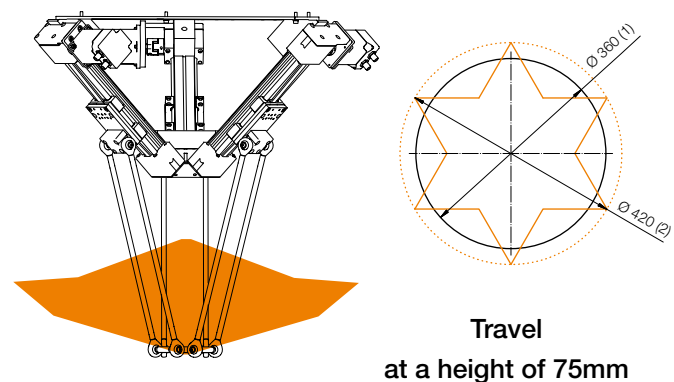
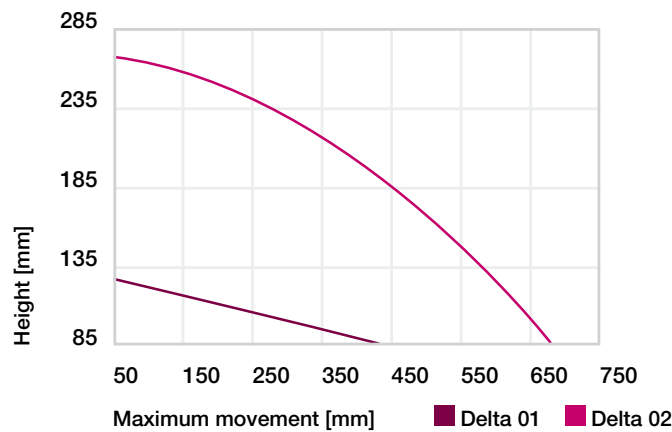
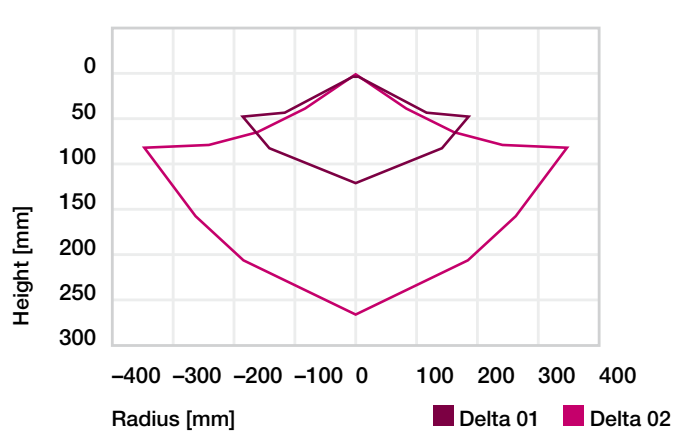

igus® Robot Control ▶ From page 718

## Delta robot kit

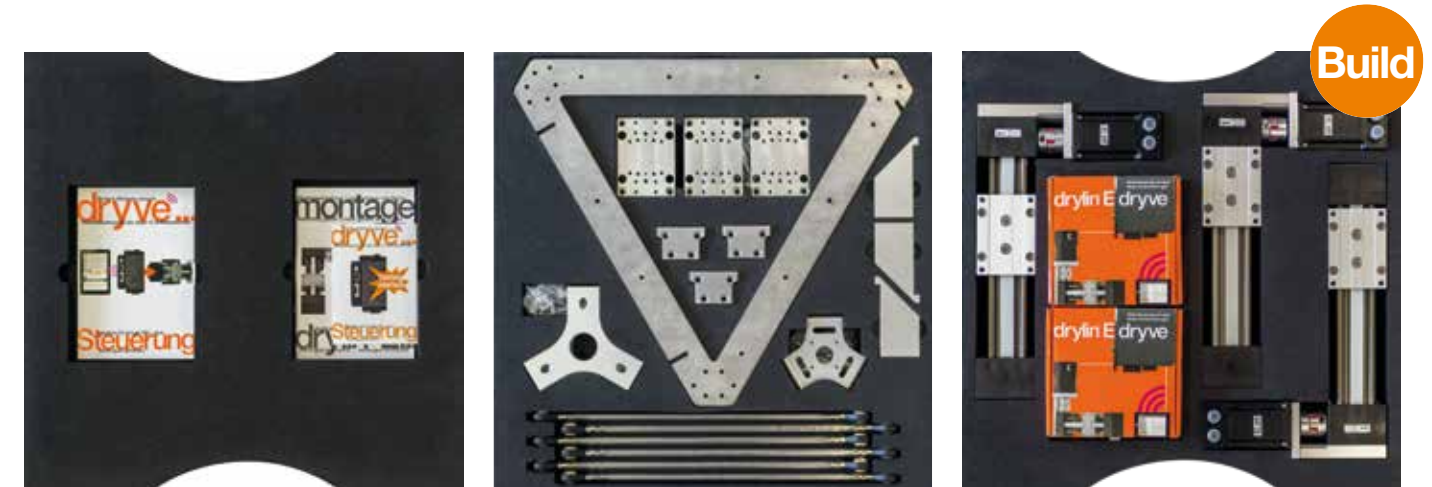

Optional accessories: initiator kits, motor encoders and sensor cables, calibrating pin, cable clip

▶ [www.igus.eu/delta-robot](http://www.igus.eu/delta-robot)

| Part No.    | Description |   |
|-------------|-------------|---|
|             | Delta 01    | Delta 02  |
| DLE-DR-0001 | DLE-DR-0050 | Delta robot, kit in compact transport box   |
| DLE-DR-0002 | DLE-DR-0051 | Delta robot, pre-installed kinematics, in transport rack made of profiled rails   |
| DLE-DR-0003 | DLE-DR-0052 | Delta robot, kit in compact transport box, incl. 3x D1 dryve stepper motor control units                                      |
| DLE-DR-0004 | DLE-DR-0053 | Delta robot, pre-installed kinematics, in transport box made of profiled rails, incl. 3x D1 dryve stepper motor control units |

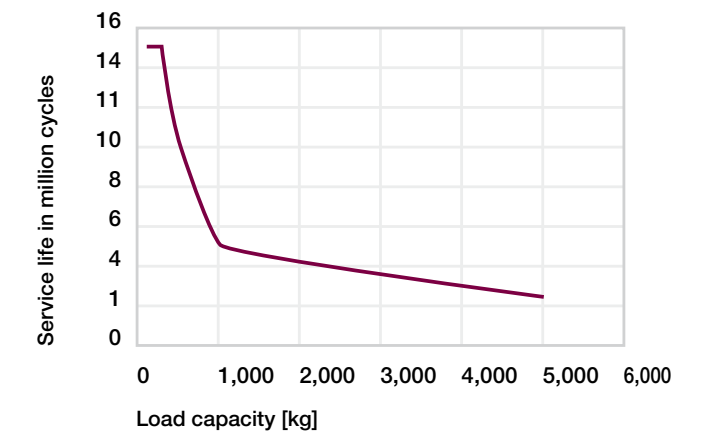
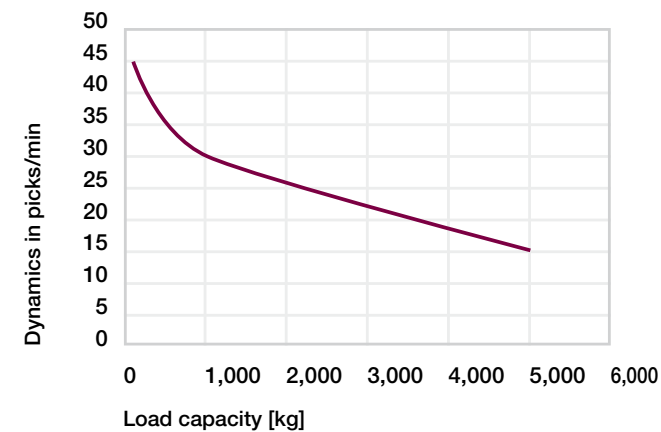

You can get the highest (picks/min) by using a master control system with path planning function. (e.g. Sinus acceleration ramp and optimised motor control parameters). Graph as shown applies to a load motor voltage of 48 [V] mounted in a stable and vibration-free frame.



Delta robot as 2-axis kinematics



- Delta robot consisting of:
- 2 drylin® toothed belt axis with NEMA23 XL stepper motor with encoder
  - Lightweight igubal® delta kinematics
  - For simple, fast and automated assembly tasks
  - Ready for connection with stepper motors for dryve D1 motor control system or as plug & play with the igus® Robot Control
- Page 718

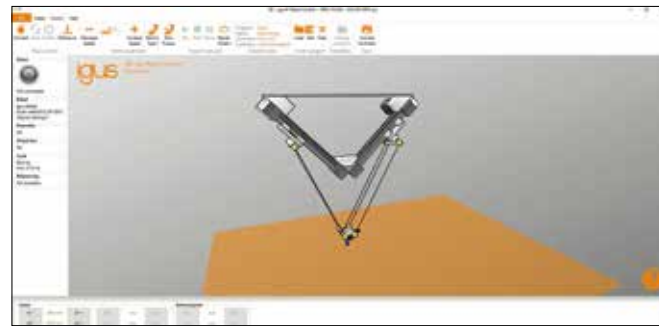

igus® Robot Control ► From page 718

Technical data

| Part No.                         |             | DLE-ZR-0001 | DLE-ZR-0002 |
|----------------------------------|-------------|-------------|-------------|
| Positioning accuracy             | [mm]        | ± 0.5       | ± 0.5       |
| Working area diameter at 75mm    | [mm]        | 400         | 700         |
| Max. payload                     | [kg]        | 5           | 5           |
| Max. process force at radius 0mm | [N]         | 100         | 100         |
| Dynamics at 500g                 | [Picks/min] | Min. 80     | Max. 45     |
| Weight                           | [kg]        | 15          | 16          |
| Track speed                      | [m/s]       | 3           | 0.7         |
| Max. acceleration                | [m/s²]      | 60          | 2           |
| Stroke -20mm for initiator       | [mm]        | 200         | 315         |
| Centre distance articulated rods | [mm]        | 450         | 550         |

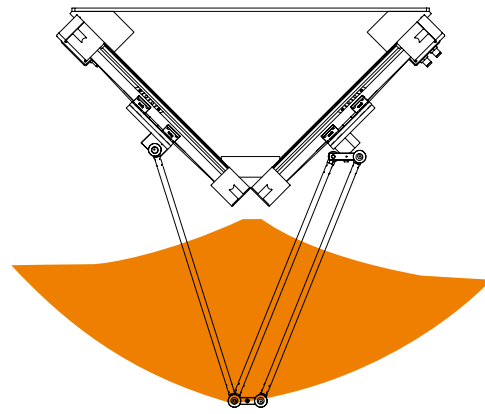
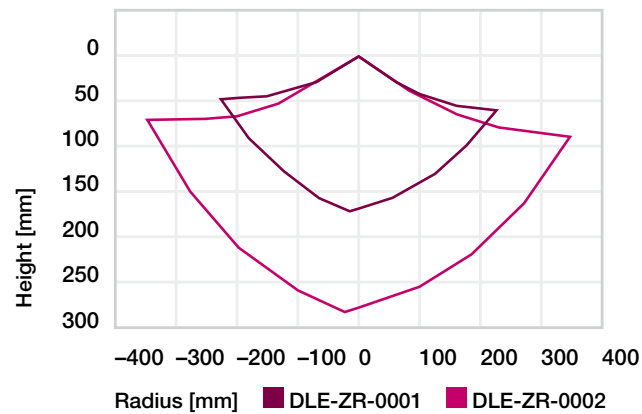

Notes

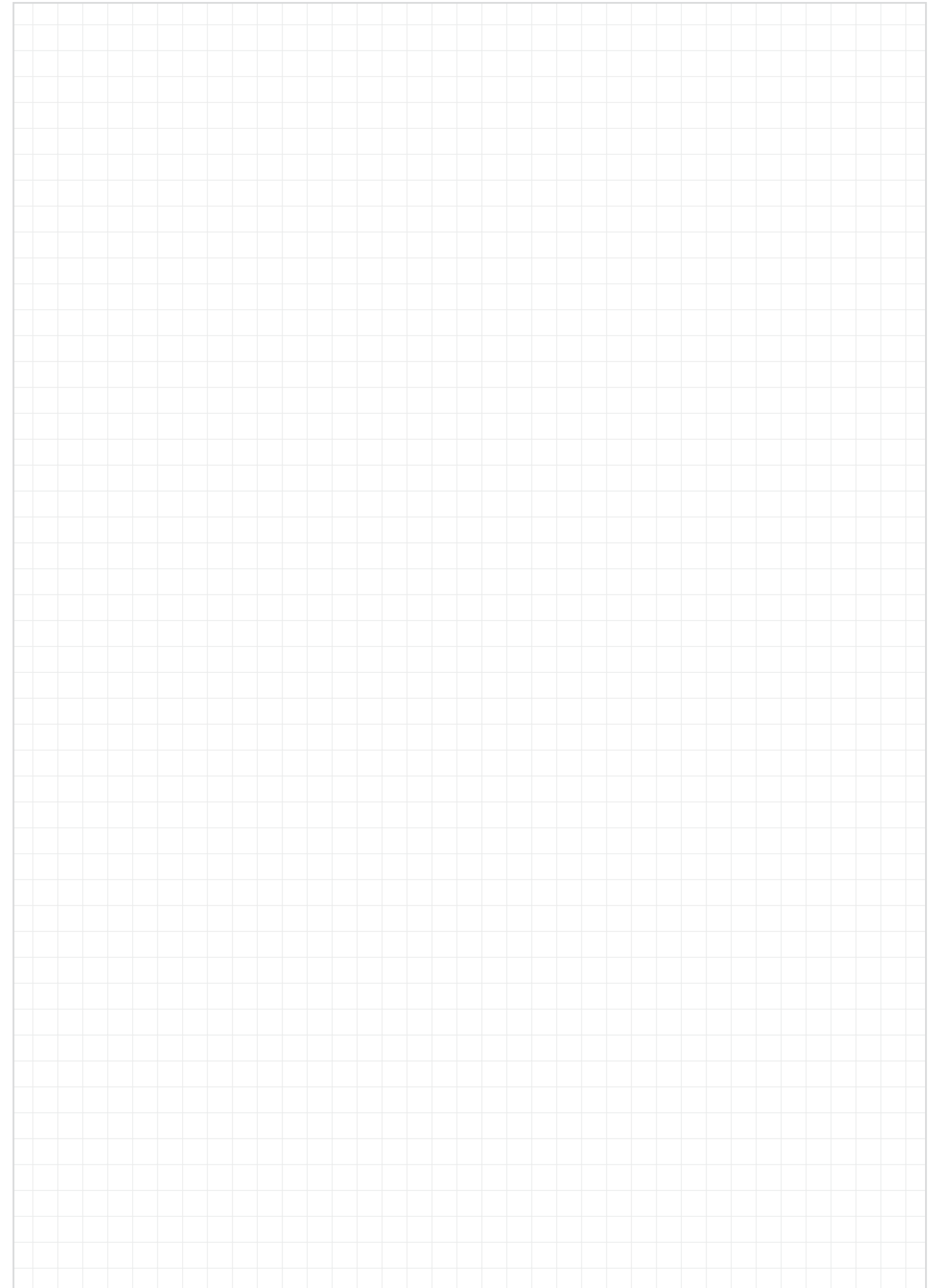

Compact, modular and lubrication-free



- Toothed, hard-anodised, corrosion-resistant square hollow section
- Combination with iglidur® J low friction element
- Modular design
- Drive: NEMA11 stepper motor

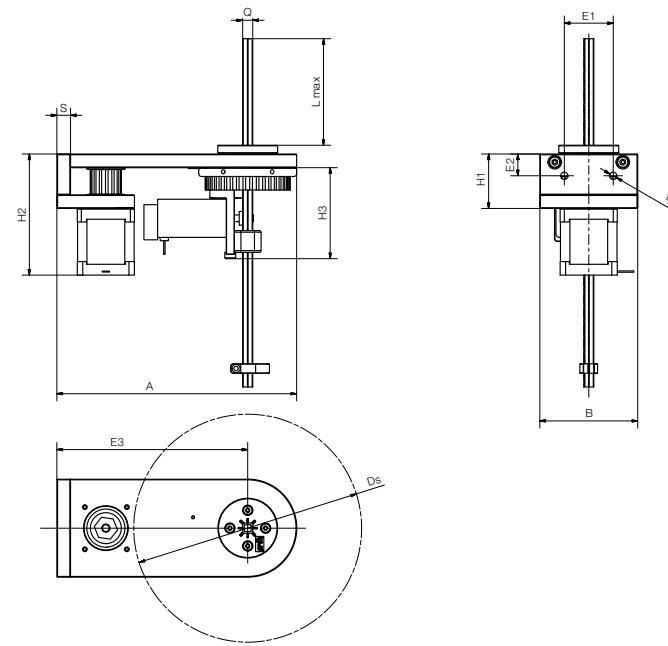

**i** Further motors upon request/suitable initiators available

### Dimensions [mm]

| Part No.        | F   | vL  | vR  | Lmax. | (Ds)  | A   | B     | H1 | (H2) | (H3) | E1 | E2 | E3  | Q   | tg  | S  |
|-----------------|-----|-----|-----|-------|-------|-----|-------|----|------|------|----|----|-----|-----|-----|----|
|                 | [g] |     |     | ±0.15 | ±0.15 |     | ±0.15 |    | ±0.3 |      |    |    |     |     | h9  |    |
| HSQ-10-1440-... | 300 | 0.5 | 0.4 | 200   | 168   | 177 | 72    | 40 | 89   | 67   | 36 | 16 | 140 | 7.5 | 5.3 | 10 |

### **🛒** Order example

**HSQ-10-1440-A-xxx-17-L-11-L**

(incl. stepper motor NEMA17/11 with stranded wire)

**HSQ-10-1440-A-xxx-17-E-11-E**

(incl. stepper motor NEMA17/11 with encoder)

Torque-resistant, controlled separately



**Torque-resistant, lubrication-free linear module. Low mass and compact in the working area.**

One linear module with two directions of motion which can be controlled separately. This way, both drives are located outside the working area. This saves space and no unnecessary motor weight is moved. The linear guide is torque-resistant and thanks to the compact modular construction, high speeds can be reached with low power.

- Quiet and lightweight
- No electronics in the working area
- Compact structure
- Corrosion-resistant

### Typical application areas:

- Medical technology
- Pick & place
- Gripper technology

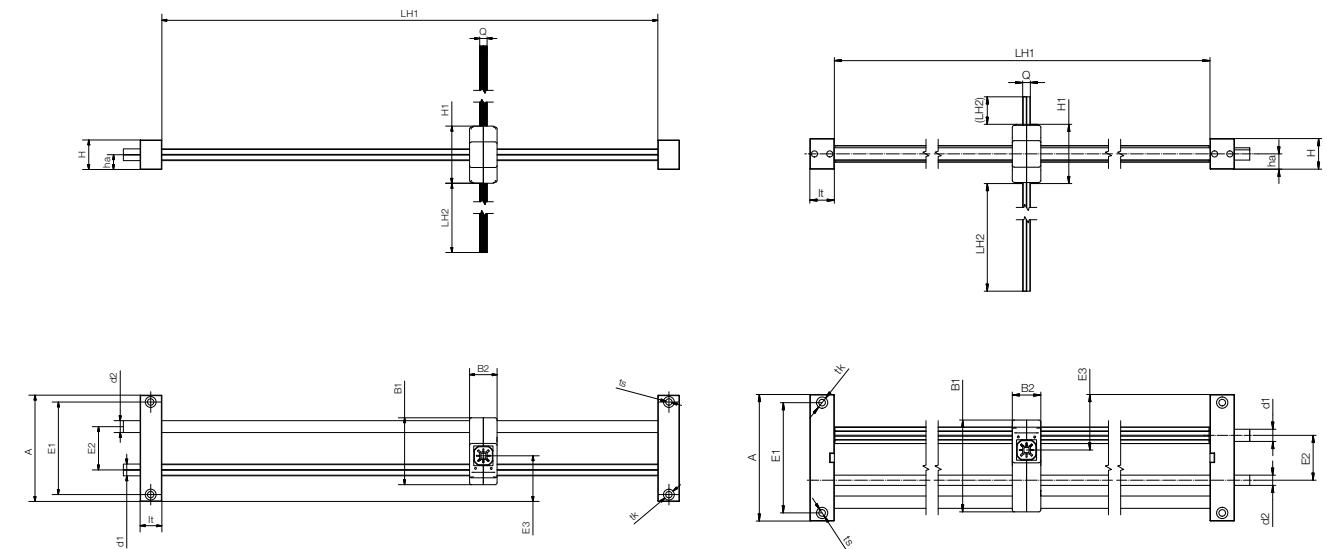

### Dimensions [mm]

| Part No.       | Max. axial F | LH1 | LH2 | H  | H1 | ha | A   | E1  | E2 |
|----------------|--------------|-----|-----|----|----|----|-----|-----|----|
|                | [N]          |     |     |    |    |    |     |     |    |
| SLQ-1210-...   | 200          | 500 | 200 | 30 | 58 | 15 | 108 | 94  | 44 |
| SLQ-121012-... | 2            | 500 | 200 | 30 | 58 | 15 | 124 | 108 | 44 |

| Part No.       | E3   | B1 | B2 | lt | d1 | d2 | ts  | tk |
|----------------|------|----|----|----|----|----|-----|----|
| SLQ-1210-...   | 46.5 | 68 | 28 | 22 | 12 | 12 | 6.6 | -  |
| SLQ-121012-... | 30.0 | 90 | 28 | 22 | 12 | 10 | 6.6 | 11 |

Fast and flexible



With and without protective housing

Individual z-axis lengths for RL-SCR-0101 available

For process speeds starting at two seconds

Can be controlled with igus® Robot Control  
▶ Page 718





Test the software free of charge

## Fast, flexible and configurable: SCARA robots

Our SCARA robots can be used individually and flexibly. The SCARA can be used for applications with precision requirements of 0.5mm with a load of up to 2kg. This type of robot is typically used at cycle times of > 30 picks/minute. The suitable igus® Robot Control software can be downloaded free of charge in advance and is available as a version with control system in the control cabinet or as a top-hat (DIN) rail version. Our SCARA robots consist largely of our tribologically optimised plastics and enable significant cost savings. They also ensure a long service life and require no maintenance.

- For process speeds starting at two seconds
- With and without protective housing
- Individual z-axis lengths for RL-SCR-0101 available
- Can be controlled with igus® Robot Control  
▶ Page 718

 **Available in 3-8 days**  
Detailed information about delivery time online.

 **Price breaks online**  
No minimum order value. No minimum order quantity

SCARA robot with three degrees of freedom



- Splash-proof thanks to protection class IP 44
- Tribologically optimised robot joints
- Joining links made of stainless steel
- Software available free of charge
- igus® Robot Control ▶ Page 718



Test the software free of charge

### Technical data

|  |                     | 3 DOF <sup>168)</sup>    |
|--|---------------------|--------------------------|
| Part No.                                       |                     | RL-SCR-0102 <b>New</b>   |
| Payload  | [N]                 | 20                       |
| Reach  | [mm]                | 560                      |
| Speed  | [Picks/min]         | 30                       |
| Min. service life                              | [Cycles]            | 10 million               |
| IP protection class                            |                     | IP44 splash water        |
| Weight   | [kg]                | 4.8                      |
| Workspace                                      | [mm]                | 560                      |
| Precision (repeatability)                      | [mm]                | ±0.5                     |
| Max. acceleration                              | [m/s <sup>2</sup> ] | 1.5                      |
| Max. speed (TCP)                               | [m/s]               | 1.0                      |
| Ambient temperature                            | [°C]                | 0 to +50                 |
| Control system as a top-hat (DIN) rail version |                     | RL-SCR-0102-48-0002-00-0 |
| Control system as a switch cabinet version     |                     | RL-SCR-0102-48-0004-00-0 |

 For more information, see the technical data sheet  
▶ [www.igus.eu/SCARA](http://www.igus.eu/SCARA)

Robot with four degrees of freedom



- Splash-proof thanks to protection class IP 45
- Tribologically optimised robot joints
- Joining links made of stainless steel
- Software available free of charge
- igus® Robot Control ► **Page 718**



Test the software free of charge

Technical data

| 4 DOF <sup>168)</sup>                          |                     |                                     |
|--|---------------------|-------------------------------------|
| Part No.                                       |                     | RL-SCR-0101 <b>New</b>              |
| Payload  | [N]                 | 20                                  |
| Reach  | [mm]                | 560                                 |
| Reach along the z-axis                         | [mm]                | 500, can be customised upon request |
| Speed  | [Picks/min]         | 30                                  |
| Min. service life                              | [Cycles]            | 10 million                          |
| IP protection class                            |                     | IP45 splash water                   |
| Weight   | [kg]                | 8.7                                 |
| Workspace                                      | [mm]                | 560 x 500                           |
| Precision (repeatability)                      | [mm]                | ±0.5                                |
| Max. acceleration                              | [m/s <sup>2</sup> ] | 1.5                                 |
| Max. speed (TCP)                               | [m/s]               | 1.0                                 |
| Ambient temperature                            | [°C]                | 0 to +50                            |
| Control system as a top-hat (DIN) rail version |                     | RL-SCR-0101-48-0002-00-0            |
| Control system as a switch cabinet version     |                     | RL-SCR-0101-48-0004-00-0            |



For more information, see the technical data sheet

► [www.igus.eu/SCARA](http://www.igus.eu/SCARA)

<sup>168)</sup> DOF: degree of freedom

SCARA robot with four degrees of freedom, with cladding



- Splash-proof thanks to protection class IP 45
- Tribologically optimised robot joints
- Joining links made of stainless steel
- Software available free of charge
- igus® Robot Control ► **Page 718**



Test the software free of charge

Technical data

| 4 DOF <sup>168)</sup>                          |                     |                          |
|--|---------------------|--------------------------|
| Part No.                                       |                     | RL-SCR-0100 <b>New</b>   |
| Payload  | [N]                 | 20                       |
| Reach  | [mm]                | 560                      |
| Reach along the z-axis                         | [mm]                | 500                      |
| Speed  | [Picks/min]         | 30                       |
| Min. service life                              | [Cycles]            | 10 million               |
| IP protection class                            |                     | IP45 splash water        |
| Weight   | [kg]                | 20.3                     |
| Workspace                                      | [mm]                | 560 x 500                |
| Precision (repeatability)                      | [mm]                | ±0.5                     |
| Max. acceleration                              | [m/s <sup>2</sup> ] | 1.5                      |
| Max. speed (TCP)                               | [m/s]               | 1.0                      |
| Ambient temperature                            | [°C]                | 0 to +50                 |
| Control system as a top-hat (DIN) rail version |                     | RL-SCR-0100-48-0002-00-0 |
| Control system as a switch cabinet version     |                     | RL-SCR-0100-48-0004-00-0 |



For more information, see the technical data sheet

► [www.igus.eu/SCARA](http://www.igus.eu/SCARA)

<sup>168)</sup> DOF: degree of freedom





Option A, control cabinet  
Part No.  
RL-IRC-SJ-003-48-02-00-0

### First robotics control software by igus®

- Diverse automation tasks with simple programming software
- For single axes, linear, flat linear, room linear, and delta robots
- Easy software installation for Windows 10
- Use with a PC or tablet
- Seven digital inputs/outputs, CRI interface, ModbusTCP (gateway from CANopen) for connection to master control systems, e.g. Siemens or Beckhoff
- 1m cable length

### Other functions:

- Teach-in: handheld control functions for linear robot systems and delta robots
- Interfaces: ModBus, digital I/Os, Ethernet CRI, ROS, etc
- Communication: Ethernet or Wi-Fi
- Sample programs: over 100 sample programs for igus® linear robots, delta robots, articulated arm robots, Scara, etc.
- Motion sequences: circular movement, velocity commands, if-then-else, matrix calculation, etc.

### **i** Option A/B Control cabinet/top-hat (DIN) rail

Scope of delivery: top-hat (DIN) rail module support, top-hat (DIN) rail module stepper, top-hat (DIN) rail module digital IO, mounting brackets and cables (CAN, supply, motor connection, 24V power supply, etc.), igus® Robot Control software for Windows, documentation



Option B, top-hat (DIN) rail  
Part No.  
RL-IRC-SJ-003-48-01-00-0

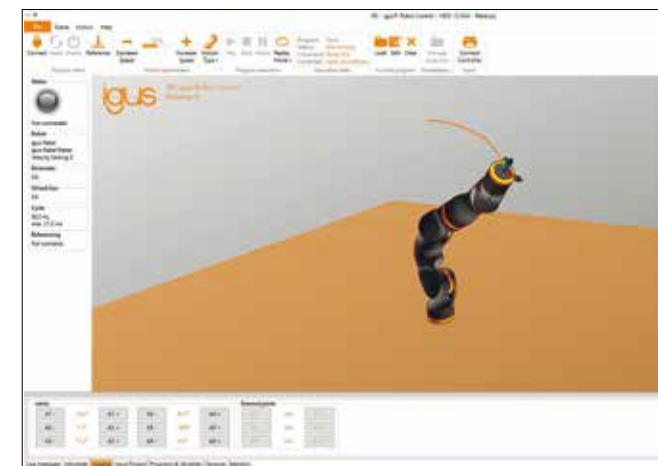
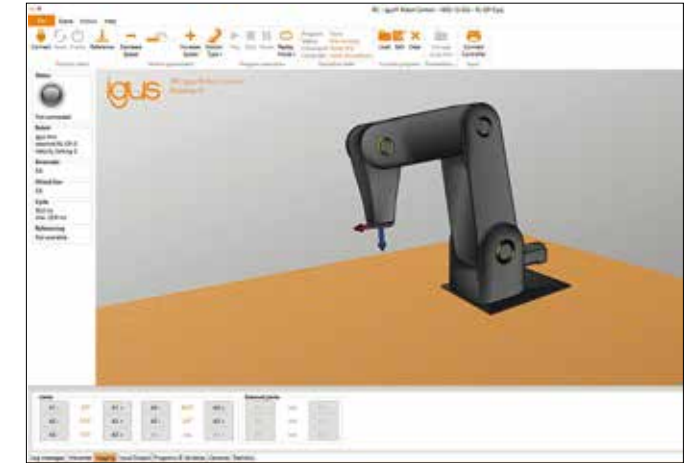
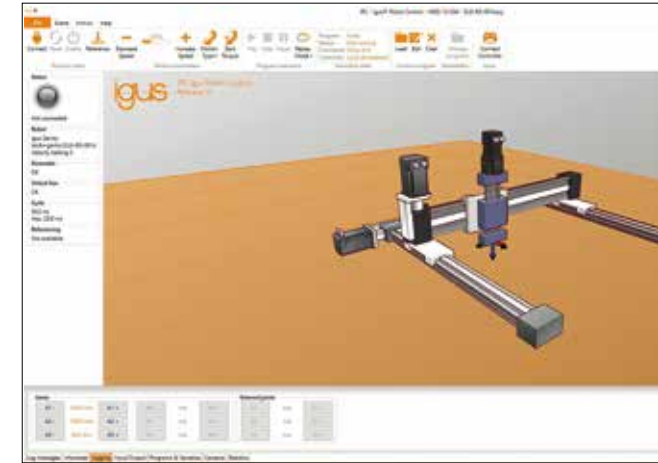

- On request**
  - ▶ [www.igus.eu/linear-robots](http://www.igus.eu/linear-robots)
  - ▶ [www.igus.eu/DP](http://www.igus.eu/DP)
  - ▶ [www.igus.eu/ReBel](http://www.igus.eu/ReBel)
  - ▶ [www.igus.eu/robolink/scara-robots](http://www.igus.eu/robolink/scara-robots)

- Software download**
  - ▶ [www.igus.eu/irc-enquiry](http://www.igus.eu/irc-enquiry)

### Technical data

|                     |        |                                      |
|---------------------|--------|--------------------------------------|
| Protection class    |        | IP30                                 |
| Ambient temperature | [°C]   | 0 to +45                             |
| Length              | [mm]   | 600                                  |
| Width               | [mm]   | 300                                  |
| Height              | [mm]   | 155                                  |
| Logic voltage       | [V/A]  | 24/5                                 |
| Output voltage      | [V DC] | 48                                   |
| Output current      | [A]    | 10                                   |
| Power               | [W]    | 480                                  |
| Signal indicators   |        | LED status indicators on the modules |
| EC approval         |        | EN 61000-6-2, EN 61000-6-3           |

Adapter kits: seventh axis for robots

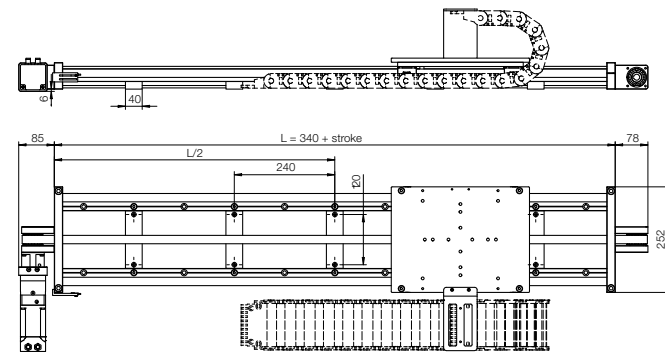

- Up to four times more workspace for robots
- Ready-to-install linear axis 7 in robotics
- Flexible stroke length of up to 3,000mm; longer stroke lengths available upon request
- Suitable adapter kits for robolink® RL-DP, Epson Scara T3 and T6; articulated arm VT6; Universal Robots UR3e, UR5e, UR10e, UR16e; and many more
- 7th axis: ZLW-20 ▶ Page 346

Adapter kit for 7th axis

| Part No.                              | Suitable for                                  |
|---------------------------------------|---|
| ZLW-20200S-7TH-DCUR-01-1 <b>New</b>   | Universal Robots UR3, UR5, UR10, robolink® DC |
| ZLW-20200S-7TH-DP-01-xxxx <b>New</b>  | robolink® DP                                  |
| ZLW-20200S-7TH-EPS-01-xxxx <b>New</b> | Epson T3, T6, VT6                             |
| ZLW-20200S-7TH-IO-01-xxxx <b>New</b>  | ReBeL®  |

Complete system consisting of ZLW-20200 and adapter kit - Part No.: ZLW-20200S-7TH-DP-01-XXX.  
There is a specific part number with the right adapter kit for the robot in question.

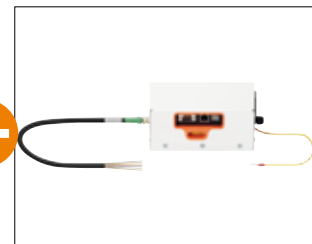

Adapter plates for Omron, Franka Emika, Doosan, Yuanda Robotics, igus® robots and much more. Please contact us.

Switch cabinet integration for 7th axis

**i** Adapter kit for UR3/UR5/UR7 is delivered in an unassembled condition. Energy chain not included in the scope of delivery. More information and ordering at: ▶ [www.igus.eu/7th-axis](http://www.igus.eu/7th-axis)

**🚚** Delivery time from 4 weeks

Rotary axis for robots

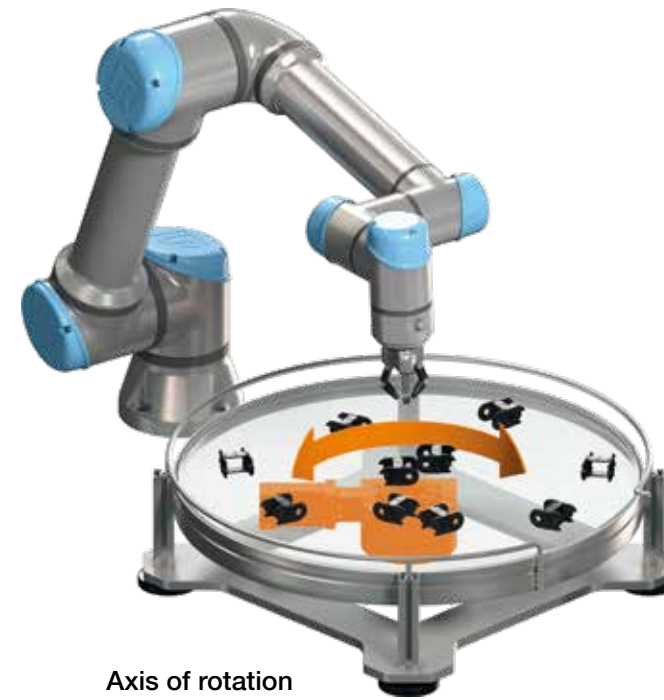

- Allows circular workpiece movements and continuous transport to various stations in a single work step
- Consists of the following components: worm gear, installation size 50, 48:1, and NEMA23XL stepper motor with connector, encoder, and proximity switch
- Worm gears with robolink® RL-D-A0210 are also possible for UR

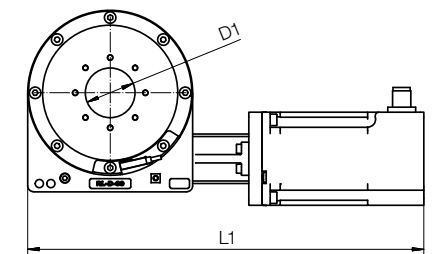
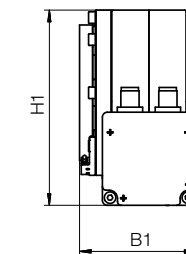

Rotary axis for robots [mm]

| Part No.                 | Max. tightening torque [Nm] | Rated speed [1/min] | Rated torque [Nm] | Installation size | Motor type    | Mechanical service life [Cycles] |
|--------------------------|-----------------------------|---------------------|-------------------|-------------------|---------------|----------------------------------|
| RL-D-50-A0210 <b>New</b> | 50                          | 6                   | 15                | 50                | Stepper motor | Min. 1,000,000                   |

Dimensions

| Part No.                 | D1 | B1 | H1   | L1 |
|--------------------------|----|----|------|----|
| RL-D-50-A0210 <b>New</b> | 50 | 6  | 15.0 | 50 |

Robot cells for all igus® robots



- Suitable for igus® articulated arm, SCARA delta, and linear robots
- Robot frame made of aluminium profiles
- One module, 50 robot types, and endless applications
- With emergency stop, start, and stop display and CE documentation
- The robot and control cabinet are installed by igus®
- Energy chains not included in the price



For more information, see the technical data sheet

► [www.igus.eu/lca-robocube](http://www.igus.eu/lca-robocube)

Technical data

| Part No.                 | Length [mm] | Width [mm] | Height [mm] | Weight [kg] | EC guideline  | Design                   |
|--------------------------|-------------|------------|-------------|-------------|---------------|--------------------------|
| ROBOCUBE-0100 <b>New</b> | 1,000       | 937.23     | 2,030       | 80          | EMC guideline | With attachment openings |
| ROBOCUBE-0101 <b>New</b> | 1,000       | 937.23     | 2,030       | 80          | EMC guideline | With doors               |



Example image



## Modular gearbox system

Worm gears

Planetary gearbox

Cantilever axis

Strain wave gear







Type Options

**RL-D-20-101-38-01033**

- robolink®
- Direct drive**
- Installation size
- Design
- Transmission ratio
- Version

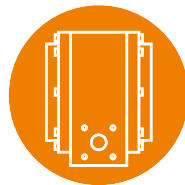
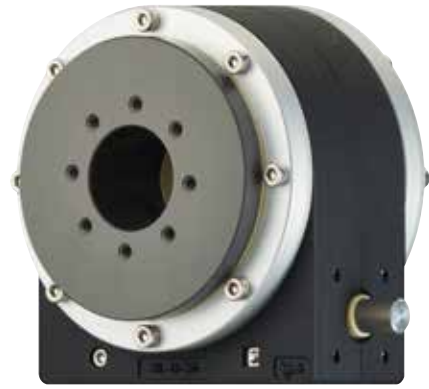

Lateral view



Gearbox technology

● Available with motor or hand wheel

### Technical data

| Part No.             | Size (H x W x D) | Shaft Ø | Transmission | Axis distance | Backlash | Breakaway torque | Max. axial dyn. load on output |
|----------------------|------------------|---------|--------------|---------------|----------|------------------|--------------------------------|
|                      | [mm]             | [mm]    | [mm/rev]     | [mm]          | [°]      | [cNm]            | [N]                            |
| RL-D-20-101-38-01033 | 90 x 80 x 67     | 8       | 1:38         | 31            | <0.5°    | < 5              | > 500                          |
| RL-D-20-101-70-01033 | 90 x 80 x 67     | 8       | 1:70         | 31            | <0.5°    | < 5              | > 500                          |
| RL-D-30-101-5-01033  | 110 x 100 x 94   | 10      | 1:5          | 40            | <0.5°    | < 7              | > 700                          |
| RL-D-30-101-50-01033 | 110 x 100 x 94   | 10      | 1:50         | 40            | <0.5°    | < 7              | > 700                          |
| RL-D-30-101-70-01033 | 110 x 100 x 94   | 10      | 1:70         | 40            | <0.5°    | < 7              | > 700                          |
| RL-D-50-101-48-01033 | 170 x 150 x 103  | 15      | 1:48         | 63            | <0.5°    | < 10             | > 1,200                        |
| RL-D-50-101-70-01033 | 170 x 150 x 103  | 15      | 1:70         | 63            | <0.5°    | < 10             | > 1,200                        |

| Part No.             | Speed at max. load | Weight | Efficiency | Breaking moment (static) | Max. output dynamic torque 12rpm |                |
|----------------------|--------------------|--------|------------|--------------------------|----------------------------------|----------------|
|                      |                    |        |            |                          | Periodic use (<30%)              | Continuous use |
|                      | [rpm]              | [g]    |            | [Nm]                     | [Nm]                             | [Nm]           |
| RL-D-20-101-38-01033 | 20                 | 610    | 0.45       | 30                       | 7.5                              | 5              |
| RL-D-20-101-70-01033 | 20                 | 610    | 0.35       | 20                       | 3.8                              | 2.5 (9rpm)     |
| RL-D-30-101-5-01033  | 12                 | 1,180  | 0.65       | 40                       | 7.5                              | 5              |
| RL-D-30-101-50-01033 | 12                 | 1,180  | 0.40       | 60                       | 15.0                             | 10             |
| RL-D-30-101-70-01033 | 12                 | 1,180  | 0.30       | 30                       | 11.3                             | 7.5 (6rpm)     |
| RL-D-50-101-48-01033 | 8                  | 3,050  | 0.40       | 180                      | 37.5                             | 25             |
| RL-D-50-101-70-01033 | 8                  | 3,050  | 0.30       | 140                      | 30.0                             | 20             |

Delivery time  
2-3 days



Type Options

**RL-D-20-102-38-01035**

- robolink®
- Direct drive**
- Installation size
- Design
- Transmission ratio
- Version

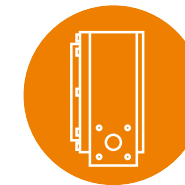

Lateral view



Gearbox technology

● Available with motor or hand wheel

### Technical data

| Part No.             | Size (H x W x D) | Shaft Ø | Transmission | Axis distance | Backlash | Breakaway torque | Max. axial dyn. load on output |
|----------------------|------------------|---------|--------------|---------------|----------|------------------|--------------------------------|
|                      | [mm]             | [mm]    | [mm/rev]     | [mm]          | [°]      | [cNm]            | [N]                            |
| RL-D-20-102-38-01035 | 90 x 80 x 67     | 8       | 1:38         | 31            | <0.5°    | < 5              | > 500                          |
| RL-D-20-102-70-01035 | 90 x 80 x 67     | 8       | 1:70         | 31            | <0.5°    | < 5              | > 500                          |
| RL-D-30-102-5-01035  | 110 x 100 x 94   | 10      | 1:5          | 40            | <0.5°    | < 7              | > 700                          |
| RL-D-30-102-50-01035 | 110 x 100 x 94   | 10      | 1:50         | 40            | <0.5°    | < 7              | > 700                          |
| RL-D-30-102-70-01035 | 110 x 100 x 94   | 10      | 1:70         | 40            | <0.5°    | < 7              | > 700                          |
| RL-D-50-102-48-01035 | 170 x 150 x 103  | 15      | 1:48         | 63            | <0.5°    | < 10             | > 1,200                        |
| RL-D-50-102-70-01035 | 170 x 150 x 103  | 15      | 1:70         | 63            | <0.5°    | < 10             | > 1,200                        |

| Part No.             | Speed at max. load | Weight | Efficiency | Breaking moment (static) | Max. output dynamic torque 12rpm |                |
|----------------------|--------------------|--------|------------|--------------------------|----------------------------------|----------------|
|                      |                    |        |            |                          | Periodic use (<30%)              | Continuous use |
|                      | [rpm]              | [g]    |            | [Nm]                     | [Nm]                             | [Nm]           |
| RL-D-20-102-38-01035 | 20                 | 470    | 0.45       | 30                       | 7.5                              | 5              |
| RL-D-20-102-70-01035 | 20                 | 470    | 0.35       | 20                       | 3.8                              | 2.5 (9rpm)     |
| RL-D-30-102-5-01035  | 12                 | 890    | 0.65       | 40                       | 7.5                              | 5              |
| RL-D-30-102-50-01035 | 12                 | 890    | 0.40       | 60                       | 15.0                             | 10             |
| RL-D-30-102-70-01035 | 12                 | 890    | 0.30       | 30                       | 11.3                             | 7.5 (6rpm)     |
| RL-D-50-102-48-01035 | 8                  | 2,300  | 0.40       | 180                      | 37.5                             | 25             |
| RL-D-50-102-70-01035 | 8                  | 2,300  | 0.30       | 140                      | 30.0                             | 20             |

Delivery time  
2-3 days





Type Options

**RL-D-20-105-38-010BB**

roboLink® Direct drive Installation size Design Transmission ratio Version

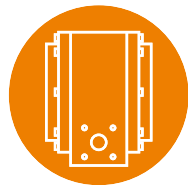

Lateral view



Gearbox technology

● Available with motor or hand wheel

Technical data

| Part No.             | Size<br>(H x W x D) | Shaft Ø | Trans-<br>mission | Axis<br>distance | Backlash | Breakaway<br>torque | Max. axial<br>dyn. load<br>on output |
|----------------------|---------------------|---------|-------------------|------------------|----------|---------------------|--------------------------------------|
|                      | [mm]                | [mm]    | [mm/rev]          | [mm]             | [°]      | [cNm]               | [N]                                  |
| RL-D-20-105-38-010BB | 90 x 80 x 67        | 8       | 1:38              | 31               | <0.5°    | < 5                 | > 250                                |
| RL-D-20-105-70-010BB | 90 x 80 x 67        | 8       | 1:70              | 31               | <0.5°    | < 5                 | > 250                                |
| RL-D-30-105-5-010BB  | 110 x 100 x 94      | 10      | 1:5               | 40               | <0.5°    | < 7                 | > 450                                |
| RL-D-30-105-50-010BB | 110 x 100 x 94      | 10      | 1:50              | 40               | <0.5°    | < 7                 | > 450                                |
| RL-D-30-105-70-010BB | 110 x 100 x 94      | 10      | 1:70              | 40               | <0.5°    | < 7                 | > 450                                |
| RL-D-50-105-48-010BB | 170 x 150 x 103     | 15      | 1:48              | 63               | <0.5°    | < 10                | > 1,000                              |
| RL-D-50-105-70-010BB | 170 x 150 x 103     | 15      | 1:70              | 63               | <0.5°    | < 10                | > 1,000                              |

| Part No.             | Speed at max.<br>load | Weight | Efficiency | Breaking<br>moment<br>(static) | Max. output dynamic<br>torque 12rpm |                   |
|----------------------|-----------------------|--------|------------|--------------------------------|-------------------------------------|-------------------|
|                      |                       |        |            |                                | Periodic use<br>(<30%)              | Continuous<br>use |
|                      | [rpm]                 | [g]    |            | [Nm]                           | [Nm]                                | [Nm]              |
| RL-D-20-105-38-010BB | 20                    | 320    | 0.45       | 30                             | 7.5                                 | 5                 |
| RL-D-20-105-70-010BB | 20                    | 320    | 0.35       | 20                             | 3.8                                 | 2.5 (9rpm)        |
| RL-D-30-105-5-010BB  | 12                    | 620    | 0.65       | 40                             | 7.5                                 | 5                 |
| RL-D-30-105-50-010BB | 12                    | 620    | 0.40       | 60                             | 15.0                                | 10                |
| RL-D-30-105-70-010BB | 12                    | 620    | 0.30       | 30                             | 11.3                                | 7.5 (6rpm)        |
| RL-D-50-105-48-010BB | 8                     | 2,730  | 0.40       | 180                            | 37.5                                | 25                |
| RL-D-50-105-70-010BB | 8                     | 2,730  | 0.30       | 140                            | 30.0                                | 20                |

Delivery time  
2-3 days



Type Options

**RL-D-20-106-38-010B5**

roboLink® Direct drive Installation size Design Transmission ratio Version

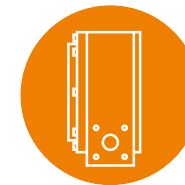

Lateral view



Gearbox technology

● Available with motor or hand wheel

Technical data

| Part No.             | Size<br>(H x W x D) | Shaft Ø | Trans-<br>mission | Axis<br>distance | Backlash | Breakaway<br>torque | Max. axial<br>dyn. load<br>on output |
|----------------------|---------------------|---------|-------------------|------------------|----------|---------------------|--------------------------------------|
|                      | [mm]                | [mm]    | [mm/rev]          | [mm]             | [°]      | [cNm]               | [N]                                  |
| RL-D-20-106-38-010B5 | 90 x 80 x 67        | 8       | 1:38              | 31               | <0.5°    | < 5                 | > 250                                |
| RL-D-20-106-70-010B5 | 90 x 80 x 67        | 8       | 1:70              | 31               | <0.5°    | < 5                 | > 250                                |
| RL-D-30-106-5-010B5  | 110 x 100 x 94      | 10      | 1:5               | 40               | <0.5°    | < 7                 | > 450                                |
| RL-D-30-106-50-010B5 | 110 x 100 x 94      | 10      | 1:50              | 40               | <0.5°    | < 7                 | > 450                                |
| RL-D-30-106-70-010B5 | 110 x 100 x 94      | 10      | 1:70              | 40               | <0.5°    | < 7                 | > 450                                |
| RL-D-50-106-48-010B5 | 170 x 150 x 103     | 15      | 1:48              | 63               | <0.5°    | < 10                | > 1,000                              |
| RL-D-50-106-70-010B5 | 170 x 150 x 103     | 15      | 1:70              | 63               | <0.5°    | < 10                | > 1,000                              |

| Part No.             | Speed at max.<br>load | Weight | Efficiency | Breaking<br>moment<br>(static) | Max. output dynamic<br>torque 12rpm |                   |
|----------------------|-----------------------|--------|------------|--------------------------------|-------------------------------------|-------------------|
|                      |                       |        |            |                                | Periodic use<br>(<30%)              | Continuous<br>use |
|                      | [rpm]                 | [g]    |            | [Nm]                           | [Nm]                                | [Nm]              |
| RL-D-20-106-38-010B5 | 20                    | 280    | 0.45       | 30                             | 7.5                                 | 5                 |
| RL-D-20-106-70-010B5 | 20                    | 280    | 0.35       | 20                             | 3.8                                 | 2.5 (9rpm)        |
| RL-D-30-106-5-010B5  | 12                    | 520    | 0.65       | 40                             | 7.5                                 | 5                 |
| RL-D-30-106-50-010B5 | 12                    | 520    | 0.40       | 60                             | 15.0                                | 10                |
| RL-D-30-106-70-010B5 | 12                    | 520    | 0.30       | 30                             | 11.3                                | 7.5 (6rpm)        |
| RL-D-50-106-48-010B5 | 8                     | 2,140  | 0.40       | 180                            | 37.5                                | 25                |
| RL-D-50-106-70-010B5 | 8                     | 2,140  | 0.30       | 140                            | 30.0                                | 20                |

Delivery time  
2-3 days



RL-D-20-A0206



RL-D-30-A0207



RL-D-50-A0129



RL-D-30-A0171



Gearbox technology

- Adaptable to various motors, standard option: NEMA17 / 23 / 23XL stepper motor
- INI kit for zero position optionally adaptable
- Motor kits available online

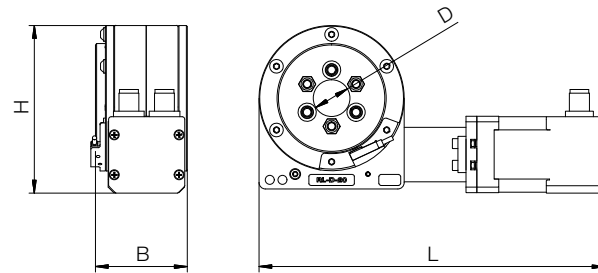

Motor kit

| Motor type               | Distance over hubs [mm] | Versions   |
|--------------------------|-------------------------|--|
| igus® stepper motor      |                         |  |
| NEMA17, NEMA23, NEMA23XL | 42, 56, 60              | -00: with strand wires<br>-01: with stepper motor without encoder<br>-02: with motor encoder<br>-NM: version without motor |

Technical data

| Joint   | Installation size 20 |       | Installation size 30 |          | Installation size 50 |            |
|---|----------------------|-------|----------------------|----------|----------------------|------------|
|   | RL-D-20-101-38-xxxxx |       | RL-D-30-101-50-xxxxx |          | RL-D-50-101-48-xxxxx |            |
| Motor   | + NEMA17             |       | + NEMA17             | + NEMA23 | + NEMA23             | + NEMA23XL |
| Motor type  | Stepper motor        |       |                      |          |                      |            |
| Weight (with standard joint)                      | [g]                  | 890   | 1,140                | 1,860    | 2,540                | 2,970      |
| Max. radial torque strength (short-term)          | [Nm]                 | 5     | 6                    | 12       | 21                   | 38         |
| Max. radial torque strength (long-term)           | [Nm]                 | 4     | 5                    | 8        | 18                   | 33         |
| Max. speed (at max. load)                         | [rpm]                | 5     | 4                    | 4        | 4                    | 4          |
| Max. axial dynamic load (horizontal installation) | [N]                  | > 500 | > 700                | > 700    | > 1,200              | > 1,200    |

Delivery time  
2-3 days



RL-D-20-A0202



RL-D-30-A0203



RL-D-50-A0204

- Assembly of robot joint, motor kit, INI kit
- Optionally with cables ► Page 674 and motor control systems ► Page 662
- Motor kits available online

Order key

| Type | Options |
|------|---------|
|------|---------|

RL-D-20-A0202

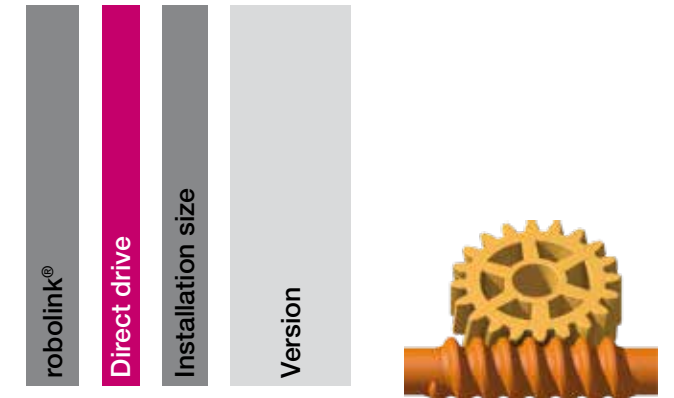

Gearbox technology

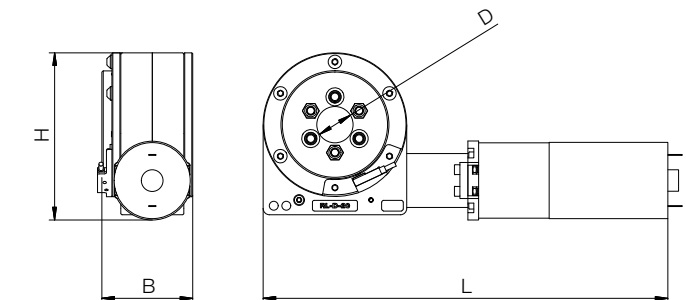

Technical data

|                      | Weight | Max. output torque | Max. speed (at max. load) | Service life gearbox                  |
|----------------------|--------|--------------------|---------------------------|---------------------------------------|
|                      | [kg]   | [Nm]               | [rpm]                     |                                       |
| Installation size 20 |        |                    |                           |                                       |
| RL-D-20-A0202        | 1.06   | 7.0                | 6                         | Min. 1,000,000 cycles <sup>169)</sup> |
| Installation size 30 |        |                    |                           |                                       |
| RL-D-30-A0203        | 1.50   | 15.0               | 3                         | Min. 1,000,000 cycles <sup>169)</sup> |
| Installation size 50 |        |                    |                           |                                       |
| RL-D-50-A0204        | 4.80   | 37.5               | 3                         | Min. 1,000,000 cycles <sup>169)</sup> |

<sup>169)</sup> At a rated torque of 2.5Nm and a rated speed of 30rpm

Dimensions [mm]

| Part No.             | D  | B    | L      | H     |
|----------------------|----|------|--------|-------|
| Installation size 20 |    |      |        |       |
| RL-D-20-A0202        | 20 | 50.5 | 233.7  | 90.0  |
| Installation size 30 |    |      |        |       |
| RL-D-30-A0203        | 30 | 63.5 | 253.7  | 110.0 |
| Installation size 50 |    |      |        |       |
| RL-D-50-A0204        | 50 | 87.5 | 303.77 | 170.5 |

Delivery time  
2-3 days



Joint



Joint with coupling



Joint with turntable



Joint with turntable on both sides



Gearbox technology

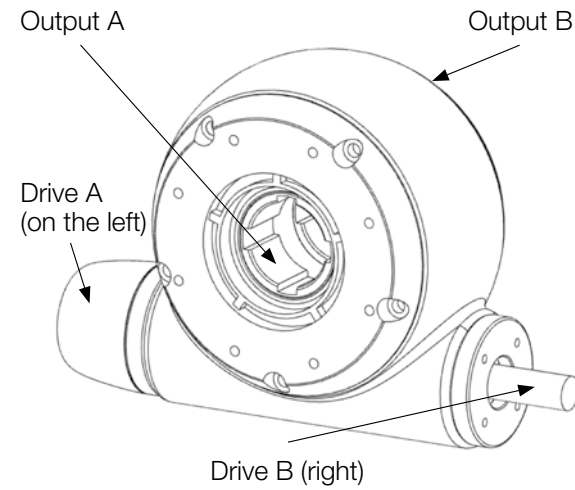

Technical data

| Designation | Transmission | Self-locking | Max. speed [rpm] | Max. output torque [Nm] | Breaking moment [Nm] | F stat. axial [N] | Backlash [°] |
|-------------|--------------|--------------|------------------|-------------------------|----------------------|-------------------|--------------|
| Joint       | 4:1          | -            | 160              | 2.5                     | 20                   | 250               | < 0.5        |
|             | 8:1          | -            | 80               | 2.5                     | 20                   | 250               | < 0.5        |
|             | 32:1         | -            | 20               | 2.5                     | 20                   | 250               | < 0.5        |
|             | 64:1         | Yes          | 10               | 1.5                     | 10                   | 250               | < 0.5        |

Apiro® iDeas



- Simply recreate ideas for automation systems
- With connection to dryspin®
- Select automation solution - download parts lists and CAD files
- ▶ [igus.eu/apiro-ideas](http://igus.eu/apiro-ideas)

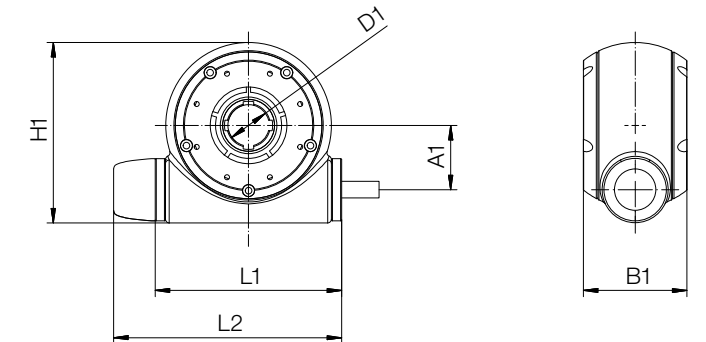

Technical data and dimensions [mm] - standard version

| Part No.    | Transmission | L1 | L2  | H1 | B1 | D1 | D2 ØT | A1 | Weight [g] |
|-------------|--------------|----|-----|----|----|----|-------|----|------------|
| RL-A10.0105 | 4:1          | 90 | 110 | 87 | 50 | 8  | 20    | 31 | 230        |
| RL-A10.0104 | 8:1          | 90 | 110 | 87 | 50 | 8  | 20    | 31 | 230        |
| RL-A10.0106 | 32:1         | 90 | 110 | 87 | 50 | 8  | 20    | 31 | 230        |
| RL-A10.0107 | 64:1         | 90 | 110 | 87 | 50 | 8  | 20    | 31 | 230        |

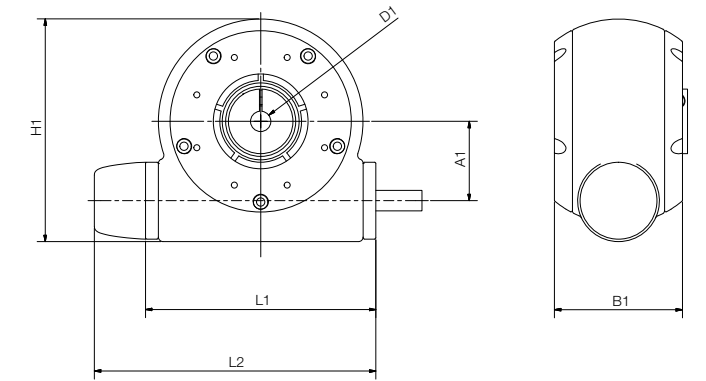

Technical data and dimensions [mm] - with coupling

| Part No.    | Transmission | L1 | L2  | H1 | B1 | D1 | D2 ØT | A1 | Weight [g] |
|-------------|--------------|----|-----|----|----|----|-------|----|------------|
| RL-A10.0117 | 4:1          | 90 | 110 | 87 | 50 | 8  | 8     | 31 | 240        |
| RL-A10.0200 | 8:1          | 90 | 110 | 87 | 50 | 8  | 8     | 31 | 240        |
| RL-A10.0118 | 32:1         | 90 | 110 | 87 | 50 | 8  | 8     | 31 | 240        |
| RL-A10.0119 | 64:1         | 90 | 110 | 87 | 50 | 8  | 8     | 31 | 240        |
| RL-A10.0220 | 4:1          | 90 | 110 | 87 | 50 | 8  | 12    | 31 | 240        |
| RL-A10.0207 | 8:1          | 90 | 110 | 87 | 50 | 8  | 12    | 31 | 240        |
| RL-A10.0204 | 32:1         | 90 | 110 | 87 | 50 | 8  | 12    | 31 | 240        |
| RL-A10.0203 | 64:1         | 90 | 110 | 87 | 50 | 8  | 12    | 31 | 240        |



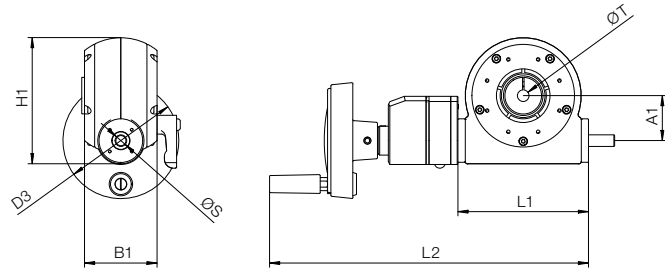

Technical data and dimensions [mm] - with coupling, manual clamp, position indicator and hand wheel

| Part No.               | Transmission | L1 | L2  | H1 | B1 | D1<br>ØS | D2<br>ØT | D3 | A1 | Weight<br>[g] |
|------------------------|--------------|----|-----|----|----|----------|----------|----|----|---------------|
| RL-A10.0129 <b>New</b> | 4:1          | 90 | 220 | 87 | 50 | 8        | 8        | 80 | 31 | 495           |
| RL-A10.0208 <b>New</b> | 8:1          | 90 | 220 | 87 | 50 | 8        | 8        | 80 | 31 | 495           |
| RL-A10.0130 <b>New</b> | 32:1         | 90 | 220 | 87 | 50 | 8        | 8        | 80 | 31 | 495           |
| RL-A10.0131 <b>New</b> | 64:1         | 90 | 220 | 87 | 50 | 8        | 8        | 80 | 31 | 495           |
| RL-A10.0221 <b>New</b> | 4:1          | 90 | 220 | 87 | 50 | 8        | 12       | 80 | 31 | 495           |
| RL-A10.0222 <b>New</b> | 8:1          | 90 | 220 | 87 | 50 | 8        | 12       | 80 | 31 | 495           |
| RL-A10.0213 <b>New</b> | 32:1         | 90 | 220 | 87 | 50 | 8        | 12       | 80 | 31 | 495           |
| RL-A10.0219 <b>New</b> | 64:1         | 90 | 220 | 87 | 50 | 8        | 12       | 80 | 31 | 495           |

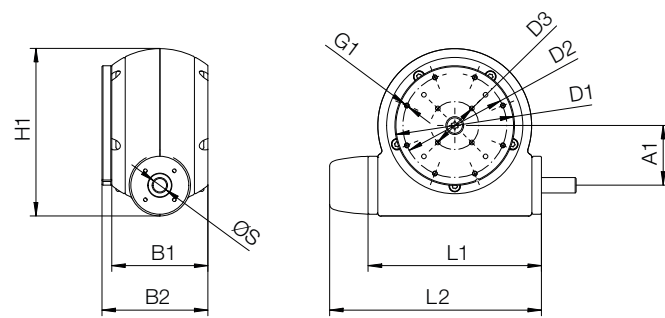

Technical data and dimensions [mm] - with turntable

| Part No.               | Transmission | L1 | L2  | H1 | B1 | B2 | D1 | D2 | D3 | S<br>Ø | A1 | G1     | Weight<br>[g] |
|------------------------|--------------|----|-----|----|----|----|----|----|----|--------|----|--------|---------------|
| RL-A10.0138 <b>New</b> | 4:1          | 90 | 110 | 87 | 50 | 55 | 62 | 54 | 25 | 8      | 31 | M3x0.5 | 250           |
| RL-A10.0170 <b>New</b> | 8:1          | 90 | 110 | 87 | 50 | 55 | 62 | 54 | 25 | 8      | 31 | M3x0.5 | 250           |
| RL-A10.0114 <b>New</b> | 32:1         | 90 | 110 | 87 | 50 | 55 | 62 | 54 | 25 | 8      | 31 | M3x0.5 | 250           |
| RL-A10.0139 <b>New</b> | 64:1         | 90 | 110 | 87 | 50 | 55 | 62 | 54 | 25 | 8      | 31 | M3x0.5 | 250           |

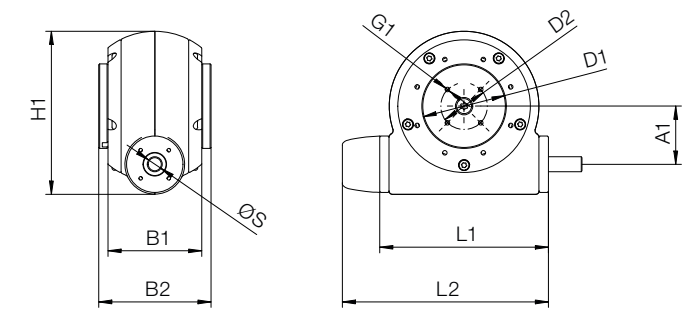
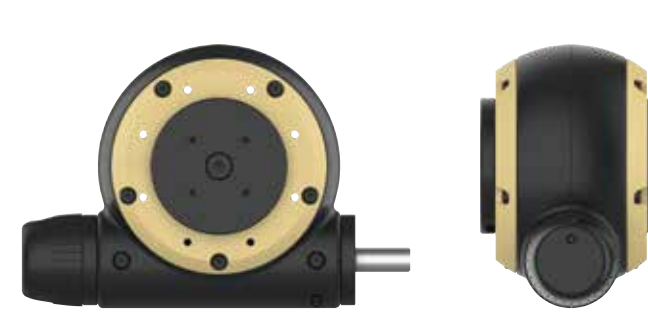

Technical data and dimensions [mm] - with turntable on both sides

| Part No.               | Transmission | L1 | L2  | H1 | B1 | B2 | D1 | D2 | S<br>Ø | A1 | G1     | Weight<br>[g] |
|------------------------|--------------|----|-----|----|----|----|----|----|--------|----|--------|---------------|
| RL-A10.0209 <b>New</b> | 4:1          | 90 | 110 | 87 | 50 | 55 | 45 | 25 | 8      | 31 | M3x0.5 | 280           |
| RL-A10.0206 <b>New</b> | 8:1          | 90 | 110 | 87 | 50 | 55 | 45 | 25 | 8      | 31 | M3x0.5 | 280           |
| RL-A10.0210 <b>New</b> | 32:1         | 90 | 110 | 87 | 50 | 55 | 45 | 25 | 8      | 31 | M3x0.5 | 280           |
| RL-A10.0211 <b>New</b> | 64:1         | 90 | 110 | 87 | 50 | 55 | 45 | 25 | 8      | 31 | M3x0.5 | 280           |

Apiro® lift/push drive



- Dry operation thanks to tribologically optimised plastics
- Adjustment can be motorised or manual
- Suitable for splash water applications
- Lightweight

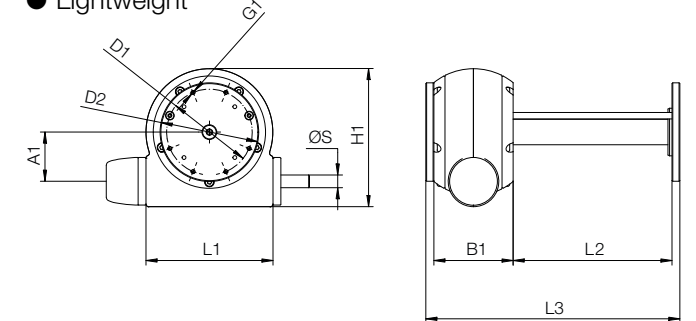

Technical data and dimensions [mm]

| Part No.                 | load<br>[N] | Feed rate<br>[mm/rev] | Stroke<br>[mm] | Speed<br>[mm/s] | L1 | L2     | H1 | B1 | D1 | D2 | S<br>Ø | A1 | G1 |
|--------------------------|-------------|-----------------------|----------------|-----------------|----|--------|----|----|----|----|--------|----|----|
| RL-A18.0101.□ <b>New</b> | 250         | 0.5                   | 10-250         | 5               | 80 | 10-250 | 87 | 50 | 27 | 62 | 8      | 31 | M3 |

Stroke freely configurable from 10-250mm



Connection to linear units



Apiro® worm gear with adapter plate

**Direct connection to drylin® drive technology**

An adapter allows Apiro® gearboxes can be mounted directly on the output journal of drylin® SHT and SLW linear modules. Thanks to this structure, drylin® systems can be synchronized and several Apiro® gearboxes connected in series.

The right adapter plate is also required for connecting a linear unit.

- Combination and synchronisation with the drylin® drive technology modular system
- Set-up instructions including parts list

An Apiro® worm gear with connection to drylin® is also needed.

► [www.igus.eu/apiro-format-adjustment](http://www.igus.eu/apiro-format-adjustment)

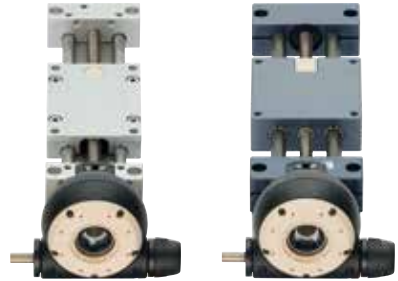

Technical data - adapter plate

| Part No.               | Available options                 |
|------------------------|-----------------------------------|
| RL-A54.0114 <b>New</b> | SHT-12 / SLW-10xx                 |
| RL-A54.0113 <b>New</b> | SLW-1660                          |
| RL-A54.0115 <b>New</b> | SHT-20                            |
| RL-A54.0117 <b>New</b> | SHT-BB-20 / SLW-BB-2080           |
| RL-A54.0116 <b>New</b> | SHT-30                            |
| RL-A54.0118 <b>New</b> | SHT-BB-30 / SLW-BB-25120          |
| RL-A54.0121 <b>New</b> | SLW-10xx (zinc shaft end support) |

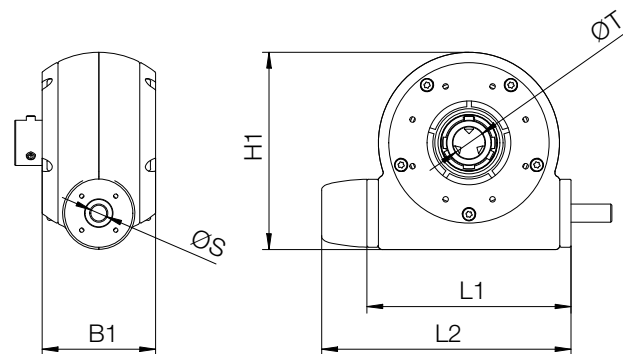

Technical data and dimensions [mm] - with connection to drylin®

| Part No.               | Transmission | L1 | L2  | H1 | B1 | D1 | D2<br>ØT | A1 | Weight<br>[g] |
|------------------------|--------------|----|-----|----|----|----|----------|----|---------------|
| RL-A10.0182 <b>New</b> | 4:1          | 90 | 110 | 87 | 50 | 8  | 14       | 31 | 240           |
| RL-A10.0183 <b>New</b> | 8:1          | 90 | 110 | 87 | 50 | 8  | 14       | 31 | 240           |
| RL-A10.0184 <b>New</b> | 32:1         | 90 | 110 | 87 | 50 | 8  | 14       | 31 | 240           |
| RL-A10.0185 <b>New</b> | 64:1         | 90 | 110 | 87 | 50 | 8  | 14       | 31 | 240           |

Also available with a hand wheel and other accessories ► [www.igus.eu/apiro-drylin](http://www.igus.eu/apiro-drylin)

Connection to linear units



**Direct connection to dryspin® lead screw technology**

Lead screws with diameters of 10, 12, and 16mm can be connected directly to Apiro® gearboxes with the output journal. Depending on the thread pitch, the lead screw can be moved.

You will find the igus® lead screw shop online:

► [igus.eu/apiro-format-adjustment](http://igus.eu/apiro-format-adjustment)

Technical data

| Part No.               | Transmission | Available options |
|------------------------|--------------|-------------------|
| RL-A10.0190 <b>New</b> | 4:1          | TR16x2            |
| RL-A10.0191 <b>New</b> | 32:1         | TR16x2            |
| RL-A10.0192 <b>New</b> | 64:1         | TR16x2            |
| RL-A10.0193 <b>New</b> | 4:1          | DS10x25           |
| RL-A10.0194 <b>New</b> | 32:1         | DS10x25           |
| RL-A10.0195 <b>New</b> | 64:1         | DS10x25           |
| RL-A10.0196 <b>New</b> | 4:1          | DS12x5            |
| RL-A10.0197 <b>New</b> | 32:1         | DS12x5            |
| RL-A10.0198 <b>New</b> | 64:1         | DS12x5            |



Synchronising drylin® linear axes with Apiro® worm gears allows automated format adjustment for the packaging and beverage industry

Rack gears



RL-A14.0107

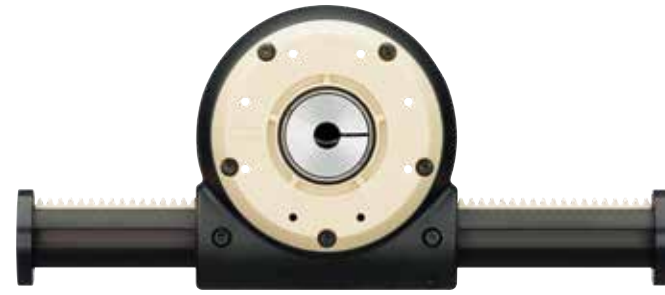

RL-A14.0109

The rack gears allow different strokes in the application and include rack and pinion elements. They are configurable in different lengths - for pusher applications, for example. The version with coupling makes it easy to synchronise several rack and pinion gears.

- Motor drive or manual drive
- Modules can be connected in series or in parallel
- INI kit available for all options
- Application temperature: +5°C to +50°C

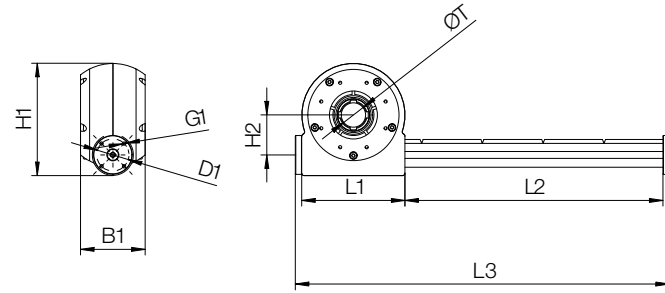

**Order example**  
**RL-A14.0107.3**  
 (rack gear, 60mm stroke)

Technical data

| Part No.   | Feed rate per rotation [mm] | Backlash [°] | Max. load [N] | Weight [g] |
|--|-----------------------------|--------------|---------------|------------|
| RL-A14.0107. <input type="checkbox"/> <b>New</b> | 125.66                      | < 0.5        | 25            | ab 330     |
| RL-A14.0109. <input type="checkbox"/> <b>New</b> | 125.66                      | < 0.5        | 25            | ab 330     |
| RL-A14.0114. <input type="checkbox"/> <b>New</b> | 125.66                      | < 0.5        | 25            | ab 330     |

Dimensions [mm]

| Part No.   | T  | L1 | H1 | H2 | B1 | D1 | G1 |
|--|----|----|----|----|----|----|----|
| RL-A14.0107. <input type="checkbox"/> <b>New</b> | 20 | 80 | 87 | 31 | 50 | 25 | M3 |
| RL-A14.0109. <input type="checkbox"/> <b>New</b> | 8  | 80 | 87 | 31 | 50 | 25 | M3 |
| RL-A14.0114. <input type="checkbox"/> <b>New</b> | 12 | 80 | 87 | 31 | 50 | 25 | M3 |

| Part No. add-on <input type="checkbox"/> | L2 Stroke | L3 Total system length |
|--|-----------|------------------------|
| ... 3                                    | 60        | 150                    |
| ... 4                                    | 110       | 200                    |
| ... 5                                    | 155       | 245                    |
| ... 6                                    | 200       | 290                    |
| ... 7                                    | 250       | 340                    |
| ... 8                                    | 295       | 385                    |
| ... 9                                    | 345       | 435                    |
| ... 10                                   | 390       | 480                    |
| ... 11                                   | 440       | 530                    |
| ... 12                                   | 485       | 575                    |
| ... 13                                   | 530       | 620                    |

| Part No. add-on <input type="checkbox"/> | L2 Stroke | L3 Total system length |
|--|-----------|------------------------|
| ... 14                                   | 580       | 670                    |
| ... 15                                   | 625       | 715                    |
| ... 16                                   | 675       | 765                    |
| ... 17                                   | 720       | 810                    |
| ... 18                                   | 770       | 860                    |
| ... 19                                   | 815       | 905                    |
| ... 20                                   | 860       | 950                    |
| ... 21                                   | 910       | 1000                   |
| ... 22                                   | 955       | 1045                   |
| ... 23                                   | 1005      | 1095                   |
| ... 24                                   | 1,050     | 1140                   |

Rack gears with integrated planetary gearbox



RL-A16.0102.XX



Gearbox technology

The Apiro® rack and pinion gear with integrated planetary gearbox allows direct connection of NEMA stepper motors or DC motors, creating a very compact unit.

- Lubrication and maintenance-free
- Greater forces possible with the same installation space
- High efficiency
- High positioning accuracy
- Transmission: 4:1

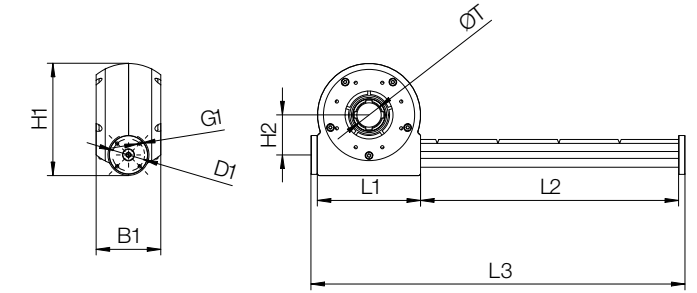

Technical data

| Part No.   | Profile diameter [mm] | Axis distance [mm] | Backlash [°] | Max. load [N] | Feed rate per rotation [mm] | Weight [g] |
|--|-----------------------|--------------------|--------------|---------------|-----------------------------|------------|
| RL-A16.0102. <input type="checkbox"/> <b>New</b> | 20                    | 31                 | < 0.5        | 25            | 31.42                       | ab 280     |

Stroke lengths according to the additional table on the left

Dimensions [mm]

| Part No.   | L1 | L2         | L3          | H1 | H2 | B1 | D1 | G1 | T  |
|--|----|------------|-------------|----|----|----|----|----|----|
| RL-A16.0102. <input type="checkbox"/> <b>New</b> | 80 | 60 - 1,050 | 150 - 1,140 | 87 | 31 | 50 | 25 | M3 | 20 |

**Delivery time**  
 2-3 days

One robot gear set for eight systems

Apiro® robot modular gearbox systems now available as a starter kit. Assemble your own robot - includes instructions.

- Lightweight due to igus® high-performance polymers
- Infinite combination options
- Individual kinematics can be implemented
- Easy assembly with the help of instructions
- Motor and magnet picker included in delivery, control system available upon request

 Part No. RL-A9.0200

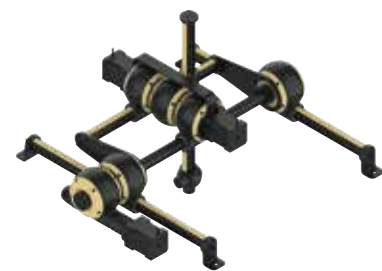

Apiro® room linear robot



Apiro® flat linear robot



Apiro® mini articulated robot



Apiro® pusher



Apiro® 2-axis picker



Apiro® 3-axis picker



Apiro® 360° picker



Apiro® SCARA

Example image

drygear® strain wave gear output shaft



Gearbox technology

- Lightweight due to igus® high-performance polymers
- Extremely compact for integration into robotics
- All-round improved performance and running performance
- A direct output shaft enables the connection of various couplings such as shaft couplings, elastomer couplings, metal ball couplings

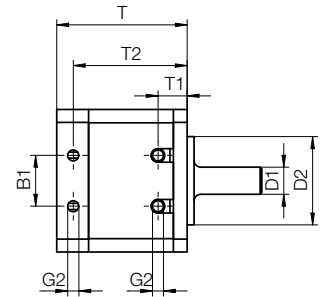
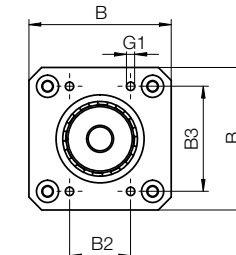
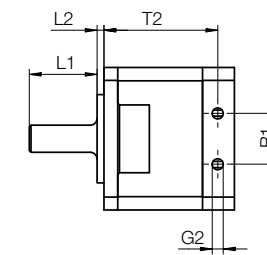

Dimensions [mm]

| Part No.                    | B  | B1 | B2 | B3 | D1<br>Ø | D2<br>Ø | G1   | G2   | L1 | T    | T1  | T2   |
|-----------------------------|----|----|----|----|---------|---------|------|------|----|------|-----|------|
| RL-S-17-28-AA-02 <b>New</b> | 42 | 15 | 18 | 31 | 8 h7    | 26 h7   | M3x4 | M4x4 | 20 | 38.5 | 8.6 | 33.6 |

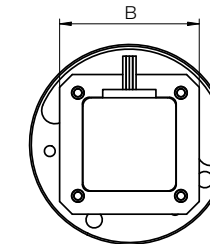
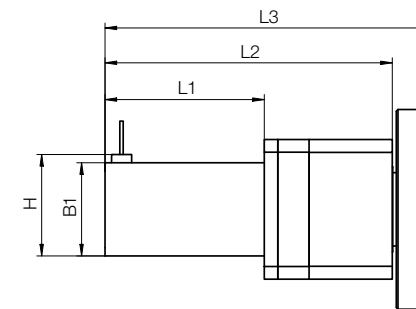

| Part No.                        | Design                            | B    | B1   | L1    | L2    | L3    | H    | Weight [g] |
|---------------------------------|-----------------------------------|------|------|-------|-------|-------|------|------------|
| RL-S-17-28-AA-N11-00 <b>New</b> | With stranded wire                | 42.0 | 28.0 | 47.5  | 87.4  | 98.6  | 30.5 | 352        |
| RL-S-17-28-AA-N11-01 <b>New</b> | With connector                    | 42.0 | -    | 67.5  | 107.4 | 118.6 | 41.0 | 375        |
| RL-S-17-28-AA-N11-02 <b>New</b> | With stranded wire and encoder    | 42.0 | 28.0 | 57.5  | 97.4  | 108.6 | 30.5 | 361        |
| RL-S-17-28-AA-N17-00 <b>New</b> | With stranded wire                | 42.0 | -    | 49.0  | 83.4  | 94.6  | 46.0 | 553        |
| RL-S-17-28-AA-N17-01 <b>New</b> | With connector                    | 42.0 | 60.0 | 70.4  | 104.8 | 116.0 | 55.0 | 602        |
| RL-S-17-28-AA-N17-02 <b>New</b> | With stranded wire and encoder    | 42.0 | 60.0 | 70.4  | 104.8 | 116.0 | 55.0 | 629        |
| RL-S-17-28-AA-N17-03 <b>New</b> | With connector, encoder and brake | 42.0 | 60.0 | 106.4 | 140.8 | 152.0 | 55.0 | 759        |

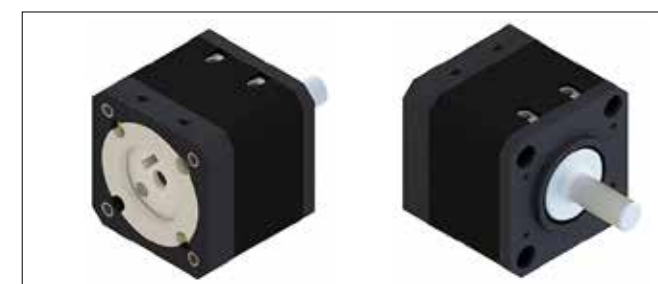

Optional couplings:

All drylin® E couplings for Ø8 shaft

Standard motor option:

Stepper motor, DC motor, BLDC motor

 Delivery time  
2-3 days





- Tribologically optimised high-performance polymers
- Flexible use of motors from the drylin® E product range
- Without lubrication for the planetary gears in the gearbox
- Lightweight construction (149.1g with a transmission of 4:1)

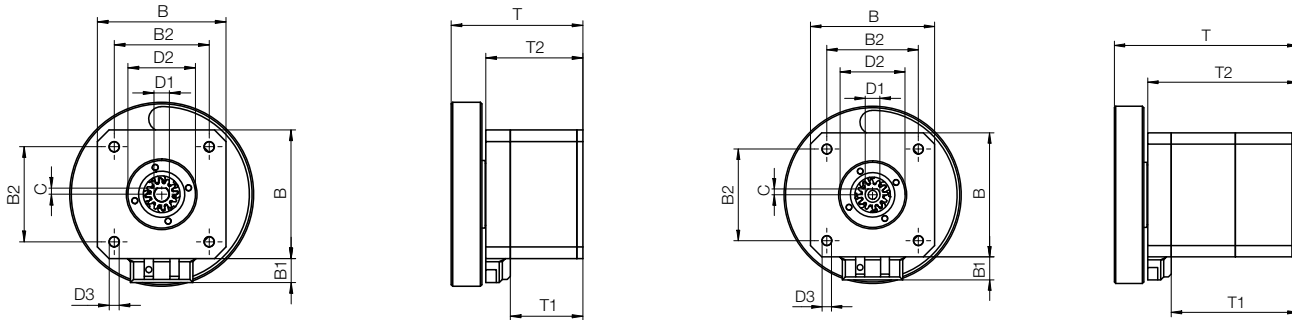

Gearbox technology

Technical data

| Part No.                 | Number of gearbox stages | Max. drive speed [rpm] | Efficiency [%] | Backlash [°] | Mechanical service life [1/min]   | Weight [g] |
|--------------------------|--------------------------|------------------------|----------------|--------------|-----------------------------------|------------|
| RL-P-17-4-AA <b>New</b>  | 1                        | >700                   | 90             | >7           | 1,000,000 cycles at 1Nm and 25rpm | 149.1      |
| RL-P-17-16-AA <b>New</b> | 2                        | >700                   | 80             | >7           | 1,000,000 cycles at 3Nm and 25rpm | 191.3      |

Dimensions [mm]

| Part No.                 | B  | B1  | B2 | D1   | D2   | D3  | C | T    | T1   | T2   |
|--------------------------|----|-----|----|------|------|-----|---|------|------|------|
|                          | ∅  | ∅   | ∅  | ∅    | ∅    | ∅   |   |      |      |      |
| RL-P-17-4-AA <b>New</b>  | 42 | 7.8 | 31 | 5x24 | 22x2 | 3.2 | 2 | 43.0 | 23.7 | 31.7 |
| RL-P-17-16-AA <b>New</b> | 42 | 7.8 | 31 | 5x24 | 22x2 | 3.2 | 2 | 62.2 | 42.9 | 50.9 |



Delivery time  
2-3 days



